



Controller to regulate CO₂ gas pressure EKC 326A

Introduction

Application

The controller can be used in systems with transcritical and subcritical cooling control systems where CO₂ is used as a refrigerant. The controller regulates the pressure in the gas cooler (condenser) so that the system achieves the optimal COP.

The controller covers the following:

- Transcritical CO₂ refrigeration systems (booster, cascade, high pressure)
- Transcritical CO₂ heat pump systems
- Transcritical CO₂ refrigeration systems with heat recovery
- Transcritical CO₂ chiller systems
- Extra capacity in warm periods. An improvement in the system's cooling performance can be achieved by displacement of the set point ("extra compressor")

Advantages

- Maximum COP
The controller guarantees the system's maximum performance by maintaining the optimal pressure in the gas cooler when regulation takes place in the transcritical range.
- The controller will always optimise to a subcritical state.
- Regulating the receiver pressure based on the receiver pressure reading
- Heat recovery with adjustable reference pressure, 0-10 V
- Optimum heat pump operation

System

The pressure in the gas cooler is controlled by the valve. Regulation must have inputs from both a pressure transmitter PGC and a temperature sensor SGC. Both must be fitted in the outlet immediately after the gas cooler. The valve is an ICMTS valve, which has been specially developed for the pressure conditions that exist in a transcritical CO₂ system. The motor section of the valve is an ICAD actuator and is controlled by a 0-10 V signal from the controller.

If it is necessary to maintain a constant receiver pressure, a valve (ETS, CCM or CCMT) and pressure transmitter (Prec) can be installed. The gas from the receiver bypasses to the inlet side of the high pressure compressor.

Functions

Maximum COP control

The controller maintains optimum pressure in the transcritical range based on a pressure and temperature reading. The reference line is defined with a point at 100 bar. The desired temperature can be set here.

Subcooling

dT subcooling can be used in the subcritical range.

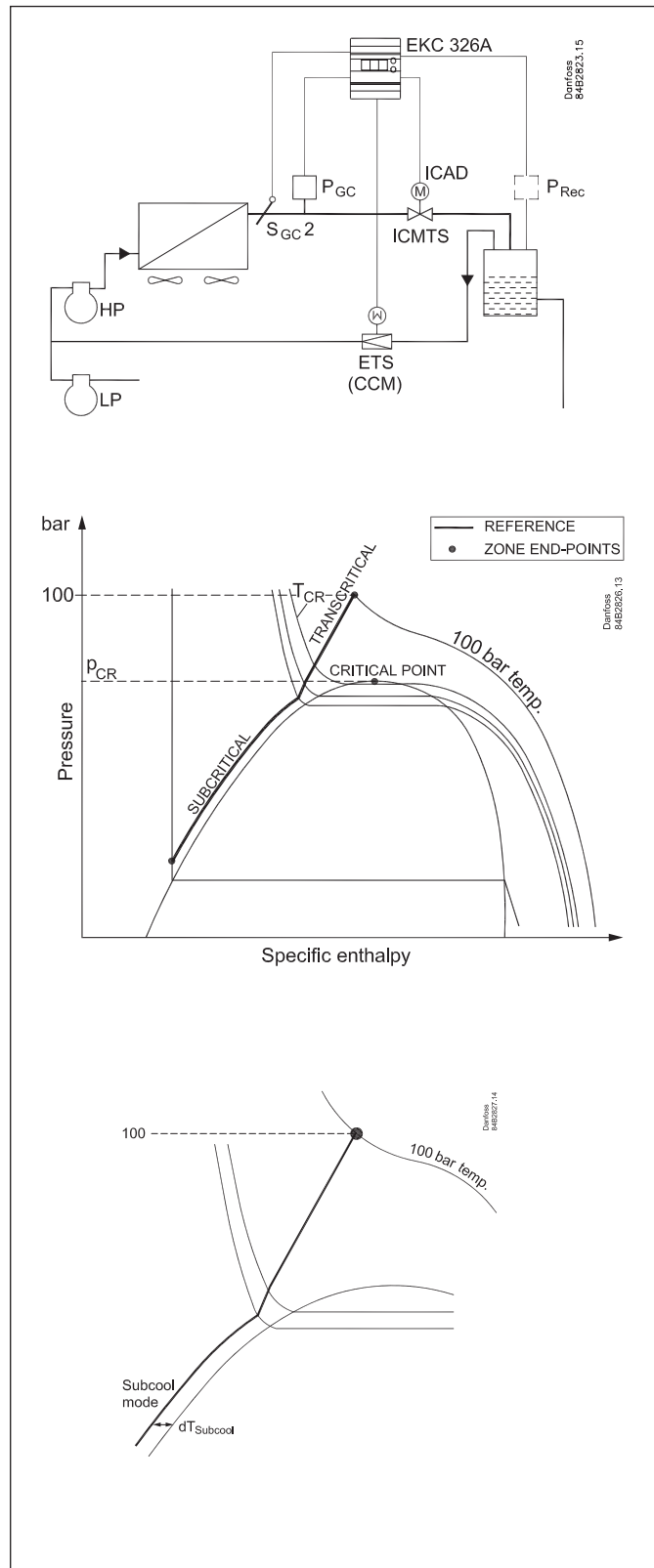

Contents

| | |
|--------------------------|----|
| Introduction | 2 |
| Examples | 4 |
| Survey of functions..... | 6 |
| Operation | 10 |

| | |
|-------------------|----|
| Menu survey..... | 10 |
| Connections | 11 |
| Data | 13 |
| Ordering | 13 |
| Appendix..... | 14 |

Receiver control

The receiver pressure can be controlled so that it is kept at a set reference point. This control requires the installation of an ETS valve a (CCM valve) and a pressure transmitter. If only monitoring and not control is required, the valve should not be installed. Install the pressure transmitter only.

Ensuring that the receiver pressure is not too low

A limit value can be set, and if the pressure falls below this value, the ICMTS valve will be opened. The valve will then open gradually through the associated P band. Open to the value "n32" (Vhp OD Max).

Protecting against high receiver pressure

A limit value can be set, and if the pressure rises beyond this value, the ICMTS valve will be closed. The valve will then close gradually through the associated P band.

Extra refrigeration capacity ("extra compressor")

This function improves the system's refrigeration capacity by increasing the reference pressure in the gas cooler with a offset value.

It is activated via a switch function.

Heat recovery or heat pump

This function will increase the gas pressure to a set value. This value will be equivalent to a specific temperature.

The value can either be fixed or can vary in accordance with an input signal of 0-10 V as follows:

A signal of 1.5 V or above can activate the function and increase the reference to Pgc HR Min.

If a variable reference is required, then a signal between 2-10 V can be connected. The signal will increase the reference further. This function works both in subcritical and transcritical ranges.

Output signal

The controller has a voltage output on 0-10 V. The signal is used to control the ICMTS valve via the ICAD actuator.

Valves opening degree

The opening degree of both ICMTS and ETS valves (CCM valve) can be narrowed if necessary.

PC-operation

The controller can be provided with data communication so that it can be connected to other products in the range of ADAP-KOOL® refrigeration controls. In this way operation, monitoring and data collection can be performed from one PC – either on the spot or in a service company.

Temperature reading

The temperature by the gas cooler must be measured using a Pt 1000 ohm sensor type AKS 21.

The sensor must be mounted immediately next to the gas cooler outlet to produce a correct signal.

Pressure reading (bar)

The pressure by the gas cooler must be measured using a pressure transmitter type AKS 2050.

The pressure transmitter must be mounted immediately next to the gas cooler outlet to produce a correct signal.

Emergency cooling

The valve's average opening degree for the last six hours is regularly saved. This opening degree is used if there is a need for emergency cooling.

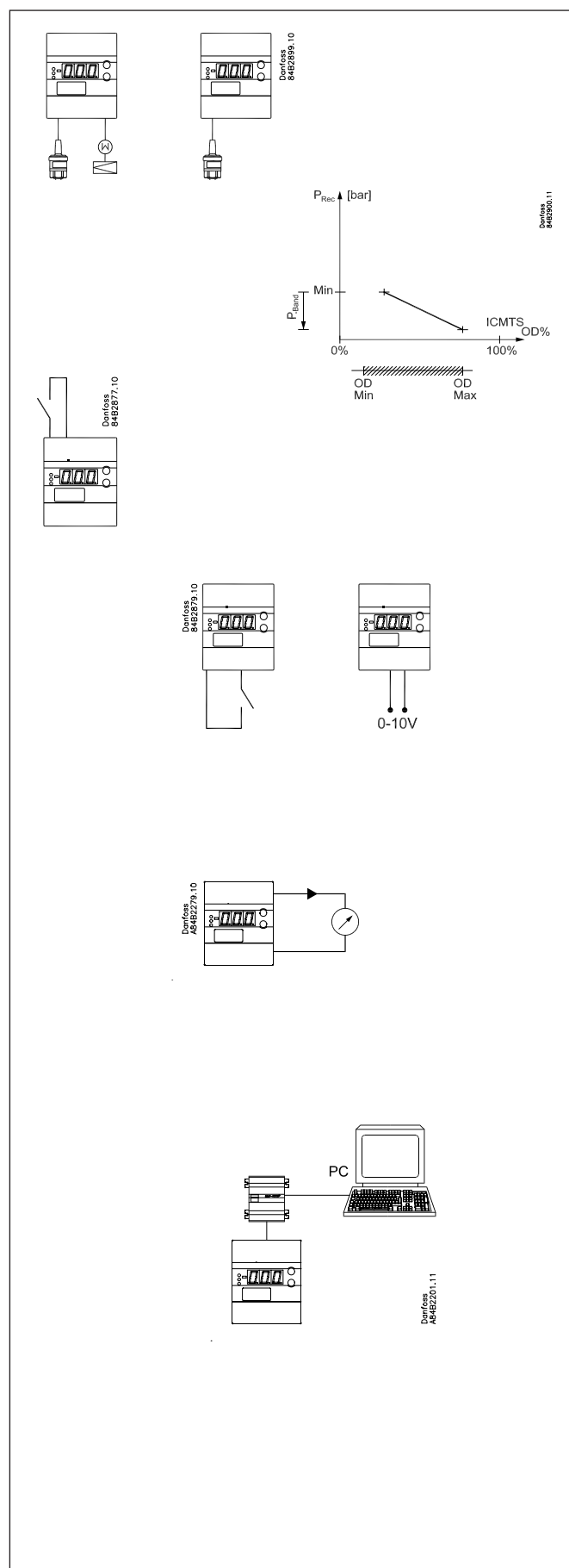

Examples

Simple heat recovery system

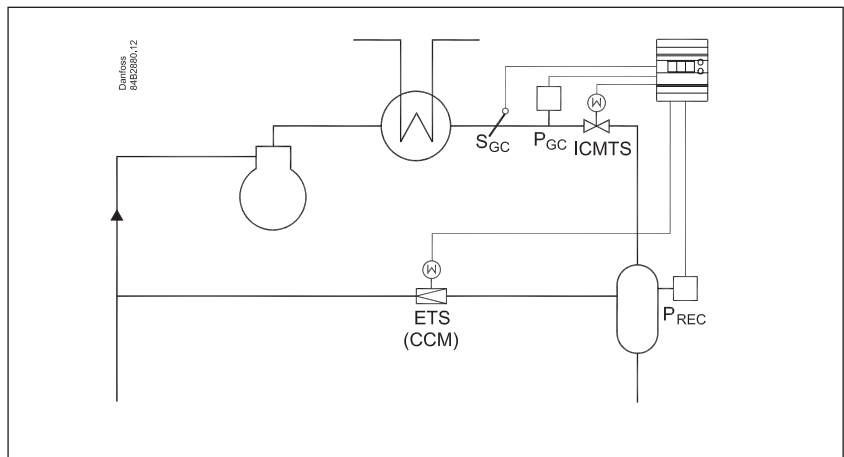

Partial heat recovery system

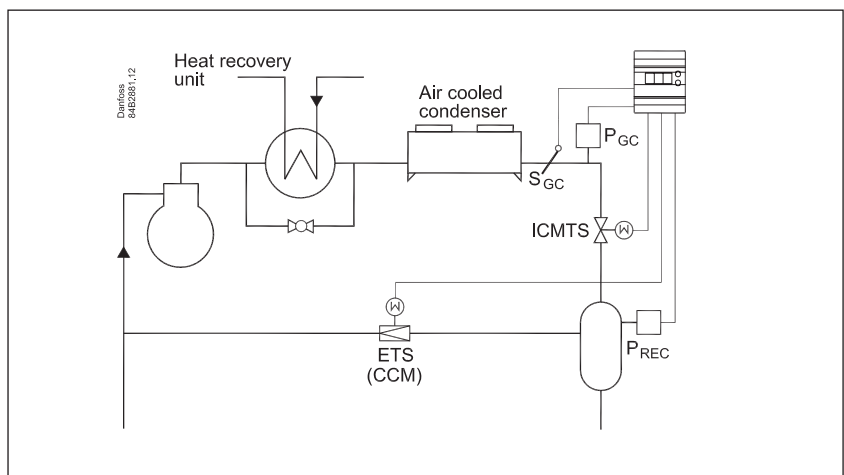

Heat recovery system (or heat pump system)

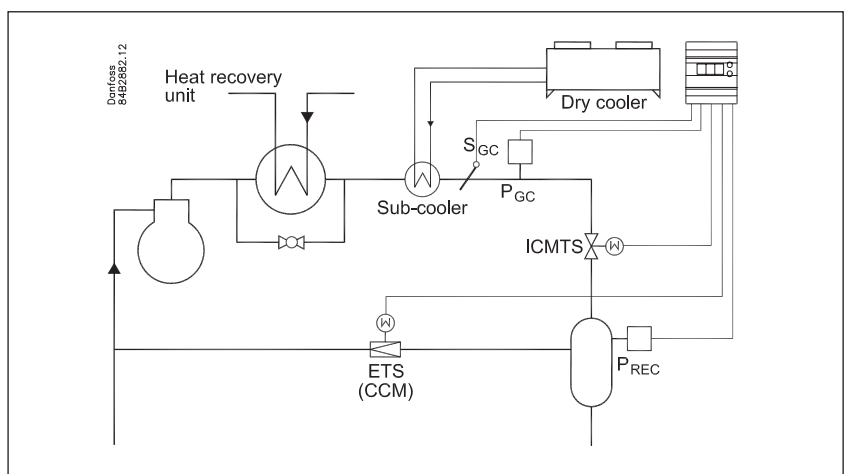

Extra refrigeration capacity ("extra compressor")

This function improves the system's refrigeration capacity by increasing the reference pressure ($P_{gc\ Ref}$) in the gas cooler. The cooling performance increases to Q_0+dQ_0 .

The function also increases the load on the compressor motor as pressure increases. Power consumption increases to Q_m+dQ_m .

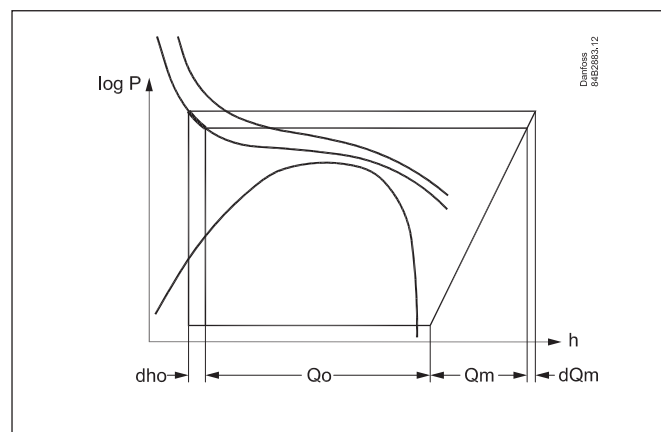

Increasing pressure reference with heat recovery

The function will increase the gas pressure reference to the $P_{gc\ HR\ Min.}$ value when it receives a signal.

The function is activated by an on/off signal at the voltage input.

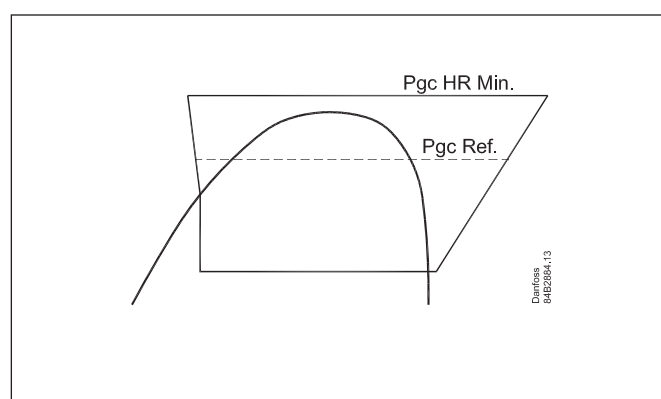

Increasing pressure reference with heat recovery, variable reference

The function will increase the gas pressure reference to the value where it receives a signal.

The function is activated by a voltage signal between 0-10 V.

- Between 0-2 V it is regulated normally
- At 2 V the reference changes to the setting "Pc HR Min"
- At 10 V the reference will increase further using the setting "Pgc HR offset"
- Between 2-10 V the reference is variable.

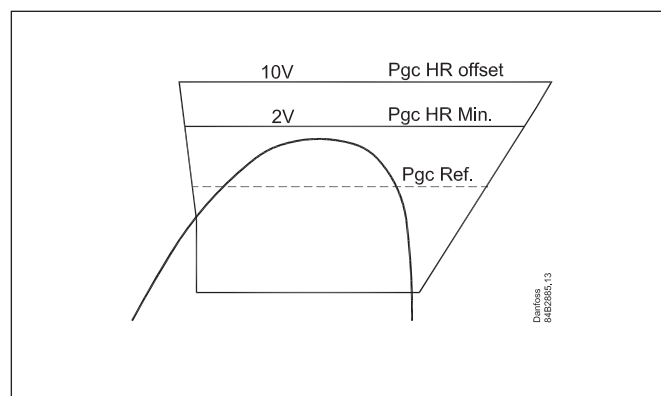

Survey of functions

| Function | Parameter | Parameter by operation via data communication |
|--|------------|---|
| Normal display | | |
| The normal display shows the pressure in the gas cooler. The pressure is measured using Pgc. The measurement can also be seen in menu U06. The control reference can be viewed by pressing both buttons. If a pressure transmitter is mounted to display the receiver pressure, the measurement can be brought up on the display by pressing the lower button. The measurement can also be seen in menu U07. | U06 U07 | Pgc bar Prec bar |
| Gas pressure control | | Gas cooler control |
| Defining the reference line Set the end point for the reference line in the transcritical range. Set the desired temperature value at 100 bar. | n99 | T100 |
| The reference The reference is pre-programmed to follow the optimal COP from the pressure/enthalpy chart. See the illustration on page 2. The current reference can be read off in menu U03. | U03 | Pgc Ref |
| Start/stop of regulation This setting can be used to start and stop regulation. Stopping regulation will always cause the valve will close at the value set in "n87" and "n93". The function in o02 requires that it has been defined. | r12 | Main Switch |
| Max. opening degree The ICMTS-valve's opening degree can be limited here. Limitation takes place by limiting the voltage signal that is sent to the valve actuator. The setting is expressed as a % of the total opening degree. The voltage signal of 0-10 V on the output will be limited correspondingly. | n32 | Vhp OD Max |
| Minimum opening degree The closing degree of the ICMTS valve can be limited here. Limitation takes place by increasing the lower part of the voltage signal that is sent to the valve actuator. The setting is expressed as a percentage of the total opening degree. The output voltage signal of 0-10 V will be limited correspondingly. | n87 | Vhp OD Min |
| The gas cooler's max. pressure This is where you define the maximum pressure permitted in the gas cooler. If the pressure reaches this value, the valve is open as set in "n32 OD max". | n69 | Pgc Max |
| P-band to force open the valve from normal regulation P-band under "n69, Pgc Max lim", where the valve is forced open so that the valve is fully open if the pressure reaches "n69, Pgc Max lim". The pressure is not critical, so opening of the valve will take place under controlled conditions. | n70 | Pgc P-band |
| The gas cooler's min. pressure This is where you define the minimum pressure permitted in the gas cooler. | n81 | Pgc Min |
| Subcooling is required to be regulated according to temperature Set the desired subcooling in K. | n79 | dT Subcool |
| P: Amplification factor Kp If the Kp value is reduced the regulation becomes slower. | n04 | Kp Gascool |
| I: Integration time Tn If the Tn value is increased the regulation becomes slower | n05 | Tn Gascool |
| Increasing refrigeration capacity This function increases the gas pressure reference. Control moves from optimum COP control to maximum refrigeration control. (The pressure increases, temperature remains unchanged and the total heat content increases.) Set the pressure increase value. The function is activated by closing the switch function on terminals 1 and 2. (see o02) | n88 | Pgc Cap Offset |

| | | |
|--|-----|----------------------------------|
| <p>Minimum pressure reference during heat recovery <i>The function can only be used if heat recovery or heat pumps are also used in the system.</i> The function will increase the gas pressure to the set value when it receives a signal. The function is activated by a voltage signal at the input to terminal 20. A voltage over 1.5 V will activate the function. (Please install a support relay if there is any risk of error signals, e.g. with long wires.) If the function is only required for displacement, r68 should be set to 0. (The gas pressure can be further increased using the r68 function.)</p> | n89 | Pgc HR Min |
| <p>Displacement of the control reference during heat recovery This function increases the reference to a value above the n89 setting, but no higher than the set value. Displacement occurs when an input voltage of above 2 V is received for terminal 20. The new reference is: Setting in n89 + displacement. The value of the displacement is determined by the voltage signal and the setting for r68. 10 V gives maximum displacement, i.e. the set value. 2 V or below will give nothing. Displacement is linear between 2 and 10 V.</p> | r68 | Pgc HR offset |
| <p>Ramp for reference modification This can be used to set the speed at which the reference must drop again following heat recovery (number bar/min). The function is only active after heat recovery is complete.</p> | r65 | Pgc Ref Ramp |
| Receiver control | | Receiver pressure control |
| <p>Receiver control Whether control of the receiver pressure should take place is defined here. On: ETS (CCM) control. Alarm active Off: No ETC (CCM) control. No alarm. Pressure control is active</p> | n90 | Prec. Ctrl |
| <p>Receiver reference The reference for receiver control is set here.</p> | n91 | Prec Ref |
| <p>Maximum opening degree The ETS (CCM) valve's opening degree can be limited here. The setting is expressed as a percentage of the total opening degree.</p> | n92 | Vgbp OD Max |
| <p>Minimum opening degree The closing degree of ETS (CCM) valves can be limited here. The setting is expressed as a percentage of the total opening degree.</p> | n93 | Vgbp OD Min |
| <p>Min. pressure in the receiver The function monitors the pressure in the receiver and will start to force open the ICMTS-valve if the pressure falls below the preset value. The value must be at least 1 bar below the reference. The function is deactivated if n72 is set to 0.</p> | n71 | Prec Min |
| <p>P-band to force open the ICMTS-valve if the receiver pressure is too low P-band under "n71, Prec Min" when the valve is forced open. If the pressure falls to n71 minus n72, the ICMTS valve will open to the value in n32, Vhp OD Max. An alarm is then transmitted. The pressure is not critical, so opening of the valve will take place under controlled conditions.</p> | n72 | Prec Min Pband |
| <p>P: Amplification factor Kp If the Kp value is reduced the regulation becomes slower.</p> | n60 | Kp Receiver |
| <p>I: Integration time Tn If the Tn value is increased the regulation becomes slower</p> | n61 | Tn Receiver |
| <p>Actuator type If receiver control takes place, the type of valve should be set: 0: ETS 12½, ETS 25, CCM 10, CCM 20 1: ETS 50, CCM 30 2: ETS 100, CCM 40 3: ETS 250 4: ETS 400 5: Other type. "n37" and "n38" should also be set when the setting = 5 ("n37" and "n38" are automatically set for settings 0 to 4) 6: CCMT 2, 4, 8</p> | n03 | Valve type |
| <p>ETS (CCM) setting Number of steps open from 0-100% Automatically set when "n03" is set to 0, 1, 2, 3, 4 or 6</p> | n37 | Max. steps |
| <p>ETS (CCM) setting Speed of spindle travel (no. of steps per second) Automatically set when "n03" is set to 0, 1, 2, 3, 4 or 6</p> | n38 | Steps / sec |

| | | |
|--|-----|---|
| Max. pressure in the receiver The function monitors the pressure in the receiver and will initiate the closing of the ICMTS valve if the pressure exceeds the preset value. The value must be at least one bar over the reference. The function is not activated when 'n59' is set to 0. (If n70 is active and attempts to open the valve, n58 will not be active.) | n58 | Prec Max |
| P-band to force closing the ICMTS-valve if the receiver pressure is too high P-band over "n58, Prec Max" when the valve is forced closed. If the pressure becomes 'n58' plus 'n59', the ICMTS valve will be closed. The closing of the valve will take place under controlled conditions. | n59 | PrecMaxPband |
| Miscellaneous | | |
| Digital input signal - DI (terminal 1 and 2) The controller has a digital input which can be used for one of the following functions: 0: The input is not used 1: External main switch (se also r12) 2: Increasing the pressure in the gas cooler (additional cooling capacity). (closed DI = additional capacity) | o02 | DI Config |
| Address If the controller is built into a network with data communication, it must have an address, and the master gateway (system unit) of the data communication must then know this address. These settings can only be made when a data communication module has been mounted in the controller and the installation of the data communication cable has been completed. This installation is mentioned in a separate document "RC8AC" | | Following installation of a data communication module, the controller can be operated on a par with the other controllers in ADAP-KOOL® refrigeration controls. |
| The address is set between 0 and 119 (999) | o03 | - |
| The address is sent to the gateway when the menu is set in pos. ON (The setting will automatically change back to Off after a few seconds.) | o04 | - |
| Frequency Set the net frequency. | o12 | 50 / 60 Hz (50=0, 60=1) |
| Pressure transmitter definition for Pgc. Pressure transmitter lower limit | o20 | MinTransPgc |
| Pressure transmitter definition for Pgc. Pressure transmitter upper limit | o21 | MaxTransPgc |
| Pressure transmitter definition for Prec. Pressure transmitter lower limit | o47 | MinTransPrec |
| Pressure transmitter definition for Prec. Pressure transmitter upper limit | o48 | MaxTransPrec |
| Alarm settings | | Alarm settings |
| Pgc Min alarm limit An alarm is issued if the value is exceeded | A65 | PgcMin ALLim |
| Permitted variation in relation to Pgc reference An alarm is issued if the Pgc pressure falls below or exceeds the permitted variation, but only once the delay time has expired. This is an 'A94 PgcRef alarm'. | A66 | PgcAl Limit |
| Permitted variation in relation to the Prec reference An alarm is issued if Prec pressure exceeds or falls below the permitted variation, but only once the delay time has expired. This is an 'A95 PrecRef alarm'. | A67 | PrecAl Limit |
| Delay time for 'A94 PgcRef alarm' | A68 | PgcAlDelay |
| Delay time for 'A95 PrecRef alarm' | A69 | PrecAlDelay |
| Service | | |
| A number of controller values can be printed for use in a service situation | | |
| Read input voltage at Ai-input | u07 | AI Volt |
| Read status of input DI (start/stop input) | u10 | DI |
| Opening degree for ETS (CCM) valve | u24 | Vgbp OD % |
| Calculated reference for regulation (desired pressure in the gas cooler) | U03 | Pgc Ref |
| The output signal to the high pressure valve ICMTS converted into opening degree | U04 | Vhp OD % |
| The temperature in the gas cooler. Measured using temperature sensor Sgc2. | U05 | Sgc2 temp. |
| The pressure in the gas cooler. Measured using pressure transmitter Pgc. | U06 | Pgc bar |
| The pressure in the receiver. Measured using pressure transmitter Prec, but only if it is mounted. | U07 | Prec bar |

| Operating status | |
|---|-------------------------------|
| The controller's operating status can be called forth by a brief (1s) activation of the upper button. If a status code exists it will be shown. (Status codes have lower priority than alarm codes. This means that status codes cannot be seen if there is an active alarm code. The individual status codes have the following meanings: | EKC State (0 = regulation) |
| S10 (off): Regulation stopped by the internal start/ stop. | 10 |
| S20: Emergency cooling is activated because of defect sensor | 20 |
| S42: Heat recovery or heat pump control is active | 42 |
| S43: Higher capacity through displacement of the pressure reference | 43 |
| Alarms | |
| E1: Fault in controller | Controller fault |
| E15: Cut-out Sgc2 sensor | Sgc2 o.c. |
| E16: Short circuited Sgc2 sensor | Sgc2 S.C. |
| E20: Fault on the signal from Pgc | Sgc input err |
| E39: Fault on the signal from Prec | Prec input err |
| A43: Step motor error. Output or phase | Step motor err |
| A45: Regulation stopped. Main switch r12 = off | Standby mode |
| A82: The Pgc gas pressure measured is higher than the maximum limit for n69 | PgcMax alarm |
| A83: The Pgc gas pressure measured is lower than the minimum limit for A65 | PgcMin alarm |
| A84: The receiver pressure measured is lower than "n71" minus "n72" | PrecMin alarm |
| A94: Pgc gas pressure measured is outside the permitted reference | PgcRef alarm |
| A95: Prec receiver pressure measured outside the permitted reference | PrecRef alarm |

Operation

Display

The values will be shown with three digits.
Temperature are to be shown in °C and pressure in bar.

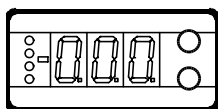

Light-emitting diodes (LED) on front panel

The four LED's will flash, if there is an error in the regulation.
In this situation you can upload the error code on the display and cancel the alarm by giving the uppermost button a brief push.

| The controller can give the following messages: | | |
|---|---------------|--|
| E1 | Error message | Fault in controller |
| E15 | | Cut-out Sgc2 sensor |
| E16 | | Short circuited Sgc2 sensor |
| E20 | | Fault on the signal from Pgc |
| E39 | | Fault on the signal from Prec |
| A43 | Alarm message | Step motor error. Output or phase |
| A45 | | Regulation stopped. Main switch r12 = off |
| A82 | | The Pgc gas pressure measured is higher than the maximum limit for n69 |
| A83 | | The Pgc gas pressure measured is lower than Pgc min (A65) |
| A84 | | The receiver pressure measured is lower than "n71" minus "n72" |
| A94 | | Pgc alarm limit "A66" is exceeded |
| A95 | | Prec alarm limit "A67" is exceeded |

The buttons

When you want to change a setting, the two buttons will give you a higher or lower value depending on the button you are pushing. But before you change the value, you must have access to the menu. You obtain this by pushing the upper button for a couple of seconds - you will then enter the column with parameter codes. Find the parameter code you want to change and push the two buttons simultaneously. When you have changed the value, save the new value by once more pushing the two buttons simultaneously.

- Gives access to the menu (or cutout an alarm)
- Gives access to changes
- Saves a change

Examples of operations

Set a menus

1. Push the upper button until a parameter is shown
2. Push one of the buttons and find the parameter you want to change
3. Push both buttons simultaneously until the parameter value is shown
4. Push one of the buttons and select the new value
5. Push both buttons again to conclude the setting

Menu survey

SW =2.0x

| Function | Parameter | Min. | Max. | Factory setting |
|---|-----------|---------|---------|-----------------|
| Normal display | | | | |
| Shows the current pressure after the gas cooler Pushing both buttons briefly will display the reference Pushing the bottom button briefly will display Prec. | - | | bar | |
| Start / stop | | | | |
| Start / stop of regulation | r12 | OFF (0) | On (1) | On (1) |
| Ramp for reference after heat recovery | r65 | 0.1 | 20 | 1 |
| Displacement of the Pgc minimum reference (n89) during heat recovery. (Displacement value at 10 V) | r68 | 0 bar | 100 bar | 0 |
| Alarm Settings | | | | |
| Alarm limit for Pgc Min. | A65 | 0 bar | 200 bar | 40 |
| Permitted Pgc reference variation 0 = no alarm function (recommended) | A66 | 0 bar | 50 bar | 0 |
| Permitted Prec reference variation 0 = no alarm function (recommended) | A67 | 0 bar | 50 bar | 0 |
| Delay time for 'A94' Pgc reference alarm | A68 | 5 min. | 360 min | 15 |
| Delay time for 'A95' Prec reference alarm | A69 | 5 min. | 360 min | 15 |
| Regulating parameters | | | | |
| Actuator type for receiver control 0=ETS12,5/25 / CCM10/20, 1=ETS50 / CCM30, 2=ETS100 / CCM40, 3=ETS250, 4=ETS400, 5=User defined (set: n37 and n38) 6=CCMT2/4/8 | n03 | 0 | 6 | 0 |
| P: Amplification factor Kp | n04 | 0.5 | 20 | 2.0 |
| I: Integration time Tn | n05 | 10 s | 600 s | 75 |
| Max. opening degree. of the valve | n32 | 0 | 100 | 100 |
| Number of steps from 0-100% opening degree (x10) ** | n37 | 0 | 500 | 262 |
| Number of steps per second | n38 | 0 | 300 | 250 |
| Max. permitted receiver pressure, Prec | n58 | 10 bar | 200 bar | 60 |
| P-belt beyond PrecMax for valve to close | n59 | 0 bar | 60 bar | 0 |
| P: Amplification factor Kp for receiver | n60 | 0.5 | 20 | 5 |
| I: Integration time Tn for receiver | n61 | 10 | 600 | 75 |
| The gas cooler's max. pressure This is where you set the maximum pressure permitted in the gas cooler. If the pressure reaches this value, the valve is fully open. | n69 | 7 | 200 | 90 |
| P-band under n69, so the valve is fully open if the pressure is n69. | n70 | 0 | 60 | 5 |
| Min. pressure in the receiver This function is only used if the pressure transmitter Prec is mounted. | n71 | 7 | 60 | 30 |
| P-band to force open the valve if the receiver pressure is too low | n72 | 0 | 60 | 3 |
| Subcooling is required to be regulated according to temperature Set the desired subcooling in K. | n79 | 1 K | 30 K | 1 |
| The gas cooler's min. pressure | n81 | 7 | 200 bar | 45 |
| Min. permissible opening degree for ICMTS | n87 | 0 | 100% | 0 |
| Extra capacity when the contact is closed. (The Pgc reference is increased with this value) | n88 | 0 bar | 200 bar | 0 |
| Minimum permitted Pgc reference during heat recovery (AI > 2 V). The value can be increased further using the r68 function. | n89 | 7 bar | 200 bar | 7 |
| Do you require receiver pressure control: Off=no, On=yes | n90 | Off | On | On |
| Prec. reference for receiver pressure control | n91 | 7 bar | 200 bar | 35 |
| Receiver pressure control. Maximum opening degree for ETS | n92 | 0% | 100% | 100 |
| Receiver pressure control. Smallest opening degree for ETS | n93 | 0% | 100% | 0 |
| Define the reference curve point at 100 bar. | n99 | 35°C | 55°C | 39 |

***) The display on the controller can show 3 digits only, but the setting value has 4 digits. Only the 3 most important will be shown. It means fx. 250 will give a setting of 2500.

| Miscellaneous | | | | |
|--|------|-------------|--------------|-----|
| Digital input signal - DI 0: The input is not used 1: External main switch 2: additional cooling capacity | o02 | 0 | 2 | 0 |
| Controller's address | o03* | 0 | 240 | - |
| ON/OFF switch (service-pin message) | o04* | - | - | - |
| Set supply voltage frequency | o12 | 50Hz (0) | 60 Hz (1) | 0 |
| Pressure transmitter range Pgc - min. | o20 | -1 bar | 5 bar | -1 |
| Pressure transmitter range Pgc - max. | o21 | 6 bar | 199 bar | 159 |
| Pressure transmitter range Prec - min. | o47 | -1 bar | 5 bar | -1 |
| Pressure transmitter range Prec - max. | o48 | 6 bar | 199 bar | 59 |

*) This setting will only be possible if a data communication module has been installed in the controller.

| Service | | | |
|--|-----|--|--------|
| Signal on AI the input | u07 | | V |
| Read status of input DI | u10 | | on/off |
| Read ETS/CCM valves opening degree | u24 | | % |
| Calculated reference for regulation (desired pressure in the gas cooler) | U03 | | bar |
| The output signal to the ICMTS valve converted into opening degree | U04 | | % |
| The temperature in the gas cooler. Measured using temperature sensor Sgc. | U05 | | °C |
| The pressure in the gas cooler. Measured using pressure transmitter Pgc. | U06 | | bar |
| The pressure in the receiver. Measured using pressure transmitter Prec, but only if it is mounted. | U07 | | bar |

Factory setting

If you need to return to the factory-set values, it can be done in this way:

- Cut out the supply voltage to the controller
- Keep both buttons depressed at the same time as you reconnect the supply voltage

Connections

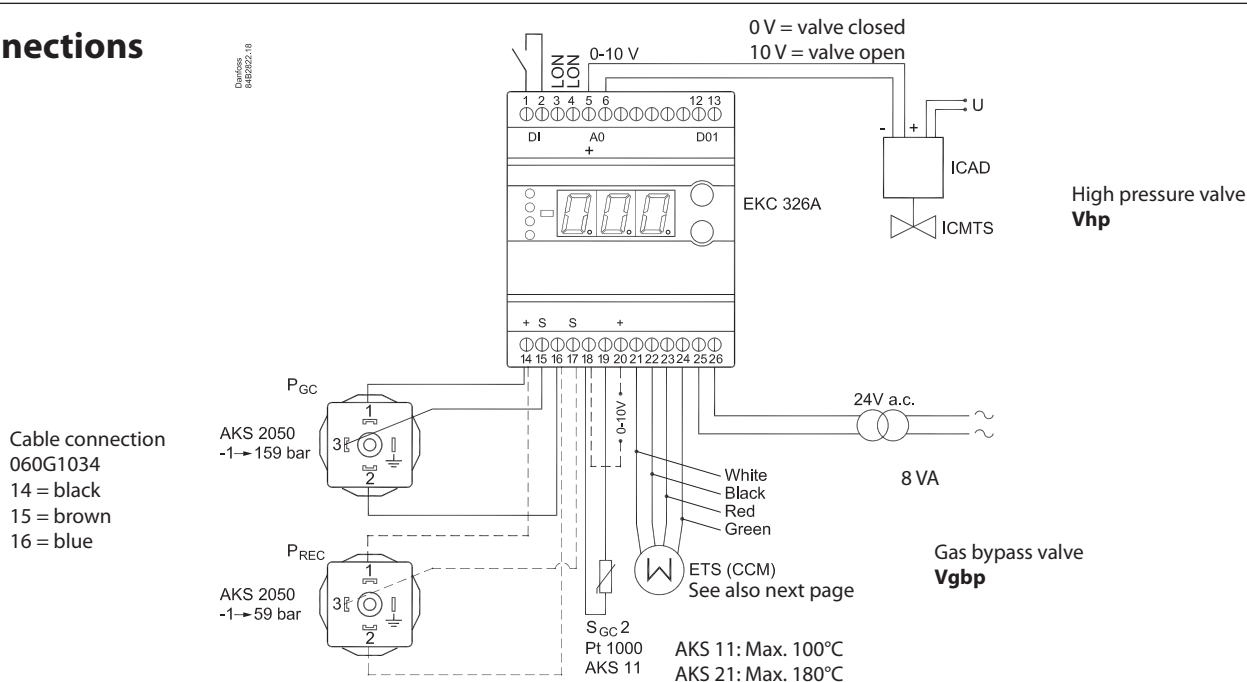

Necessary connections

Terminals:

- 25-26 Supply voltage 24 V a.c.
- 18-19 Pt 1000 sensor at gas cooler outlet (S_{GC2})
- 14,15,16 Pressure transmitter AKS 2050, -1 to 159 bar
To register the correct pressure it must be mounted as close as possible to the gas cooler.
- 5-6 Voltage output to control the ICMTS valve.

Important
PGC and SGC2 must be mounted near the gas cooler outlet to produce a correct signal.

Application dependent connections

Terminals:

- 1-2 DI-input to either:
External main switch (see o02 and r12)
OR
Contact function for increasing capacity (optimised COP operation stopped). (see o02)
Open connection = optimised COP operation
Closed connection = extra capacity.
- 12-13 Alarm relay
There is connection between 12 and 13 in alarm situations
- 14,16,17 Optional. A pressure transmitter can be connected so that the pressure in the receiver can be monitored. The pressure transmitter must be an AKS 2050, -1 to 59 bar.
- 21-24 If receiver pressure is to be controlled, a CCM or ETS valve should be connected.
- 18-20 Heat recovery. A voltage signal between 2 and 10 V will increase the gas pressure reference.
- 3-4 Data communication
Mount only, if a data communication module has been mounted.
It is **important** that the installation of the data communication cable be done correctly. Cf. separate literature No. RC8AC...

ETS (CCM) connection

If the distance between EKC 326A and the ETS (CCM/CCMT) valve exceeds 5 m a filter must be mounted to obtain the correct valve function. The filter must be placed close to EKC 326A.

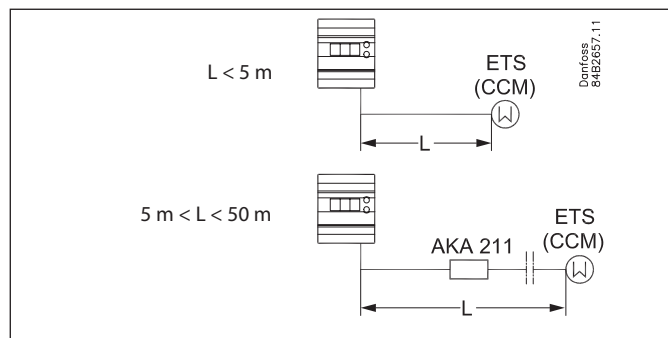

Connection

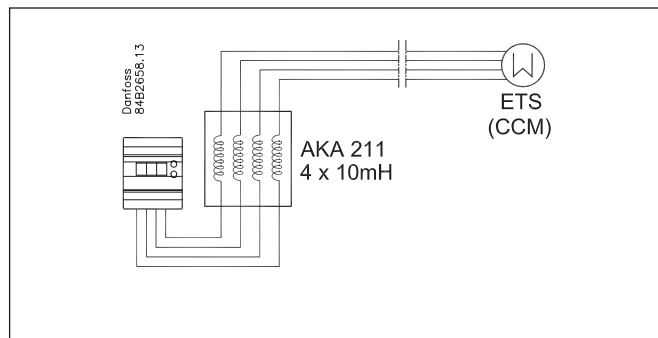

Dimensions

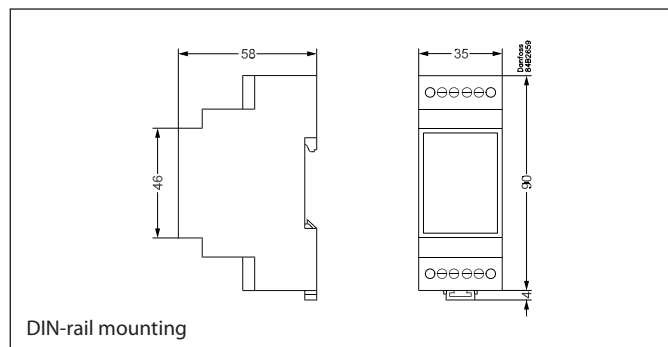

Ordering

| Type | Description | Ordering |
|---------|---------------------|-----------------|
| AKA 211 | Filter 4 x 10 mH | 084B2238 |

Data

| | | |
|--------------------|---|---|
| Supply voltage | 24 V a.c. +/-15% 50/60 Hz (the supply voltage is galvanically separated from the input and output signals) | |
| Power consumption | Controller | 8 VA |
| Input signal | Pressure transmitter | Ratiometric, AKS 2050 |
| | Pressure transmitter | Ratiometric, AKS 2050 |
| | Digital input from external contact function | |
| | Voltage signal | 0-10 V Ri = 100 k ohm Signal range = 2-10 V |
| | Sensor input | 1 pcs. Pt 1000 ohm |
| Alarm relay | 1 pcs. SPST | 250 V a.c. AC-1: 4 A (ohmic) AC-15: 3 A (inductive) |
| Actuator | ICAD mounted on ICMTS | Voltage signal 0-10 mA |
| | ETS or CCM | Step motor |
| Data communication | Possible to connect a data communication module type EKA 174 | |
| Environments | -10 to +55°C, during operations | |
| | -40 to +70°C, during transport | |
| | 20 - 80% Rh, not condensed | |
| | No shock influence / vibrations | |
| Enclosure | IP 20 | |
| Weight | 300 g | |
| Mounting | DIN rail | |
| Display | LED, 3 digits | |
| Terminals | max. 2.5 mm ² multicore | |
| Approvals | EMC acc. EN 61000-6-3 and EN 61000-6-2 LVD acc. EN 60730-1 and EN 60730-2-9 | |

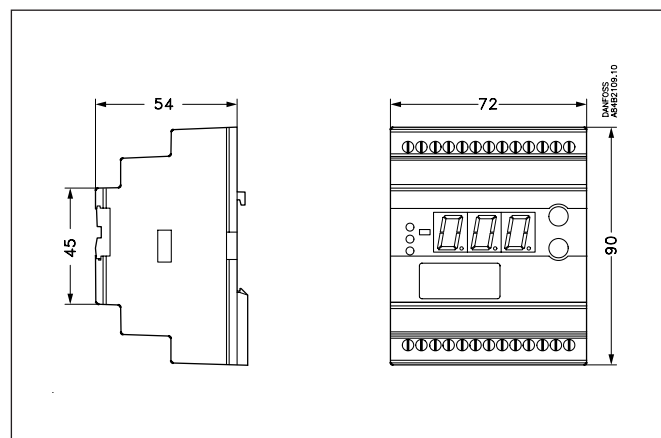

Ordering

| Type | Function | Code no. |
|----------|---|-----------------|
| EKC 326A | Gas pressure controller | 084B7252 |
| EKA 174 | Data communication module (accessories), (Lon-RS 485 module) with galvanic separation | 084B7124 |

Temperature sensor Pt 1000 ohm: Kindly refer to catalogue RK0YG
 Pressure transmitter type AKS 2050 Kindly refer to tech.broch RD5GJ

Appendix

Guideline for setting automatic safety control

The following ratio between pressure and temperature can be used to set the automatic safety control.

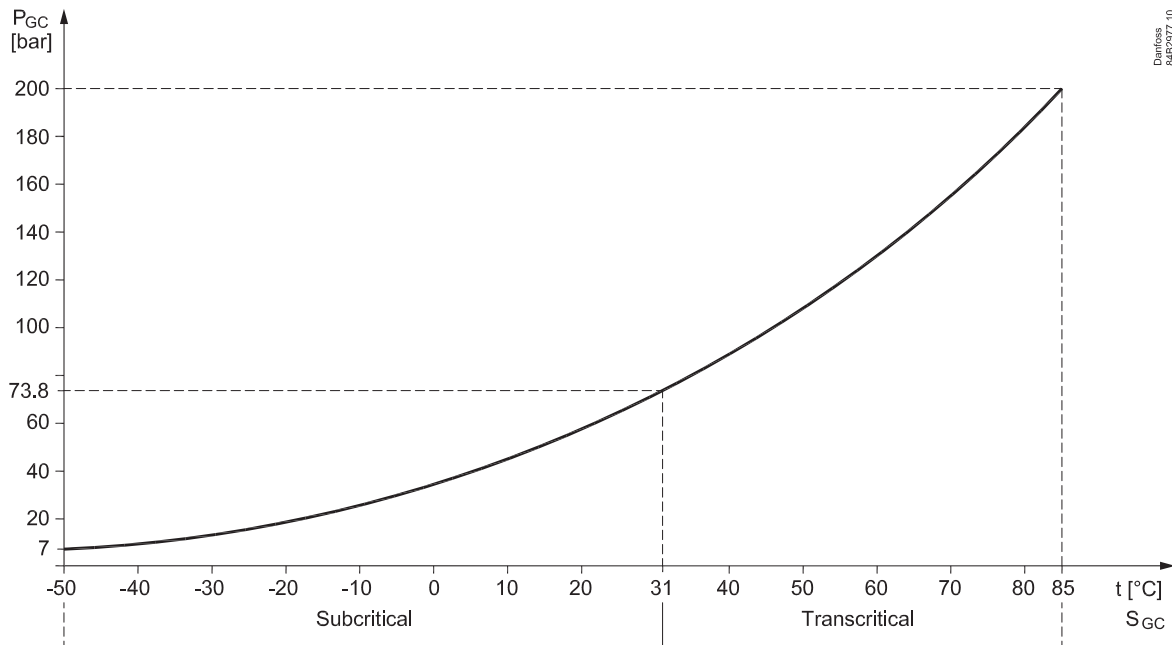

Safety functions

There are two safety functions for the receiver. They are only available for gas-cooled regulation.

A P-belt must be installed to be able to regulate the function, but both are standard set to zero, which makes the function inactive.

Receiver pressure's max. limit

Set a max. receiver pressure. If the controller register receiver pressure beyond the set value, the ICMTS valve will be closed. The opening degree will be linear through the p-band so that the ICMTS valve will be closed by pressing 'set max. receiver pressure' plus 'set-p-band'.

If the valve's opening degree is set to a limited value and cannot be fully closed, the set opening degree value will be at the pressure 'set max. receiver pressure' plus 'set p-band'.

As such, gas can still be sent through the valve.

Receiver pressure's min. limit:

A minimum receiver pressure limit can be set. If the controller register receiver pressure below the set value, the ICMTS valve will be opened. The opening degree will be linear through the p-band, and the maximum permitted opening degree of the ICMTS will be present by pressing 'set min. receiver pressure' minus 'set-p-band'. If the setting of the valve's opening degree is limited and it cannot be fully opened, the set opening degree value will be at the pressure 'set min. receiver pressure' minus 'set p-band'.

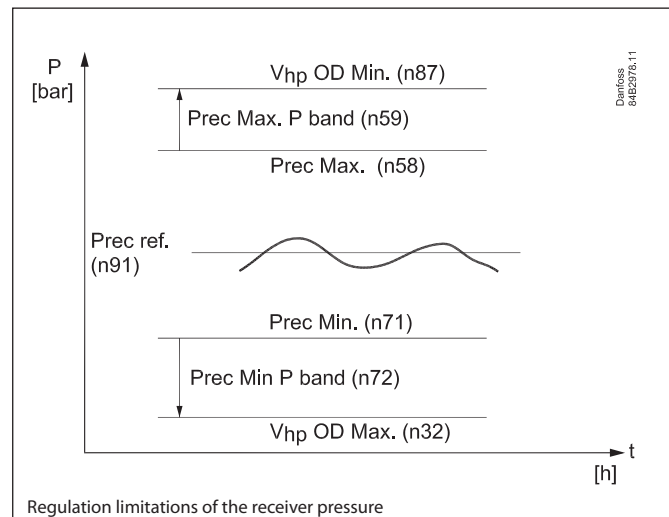

Note

The PI regulation of the receiver pressure must have space to regulate without restrictions.

This means that there should be sufficient space for the PI regulation to move around the reference, i.e. at least 2-3 bars – both over and below the reference.

The value is very dependent on the tuning of the PI regulation and the system dynamics.

An example may be a 40-bar plant in which the receiver's reference pressure is set to 35 bars. Here the system can interfere with normal regulation because the high pressure limit is very stringent.

Functions for regulation reference

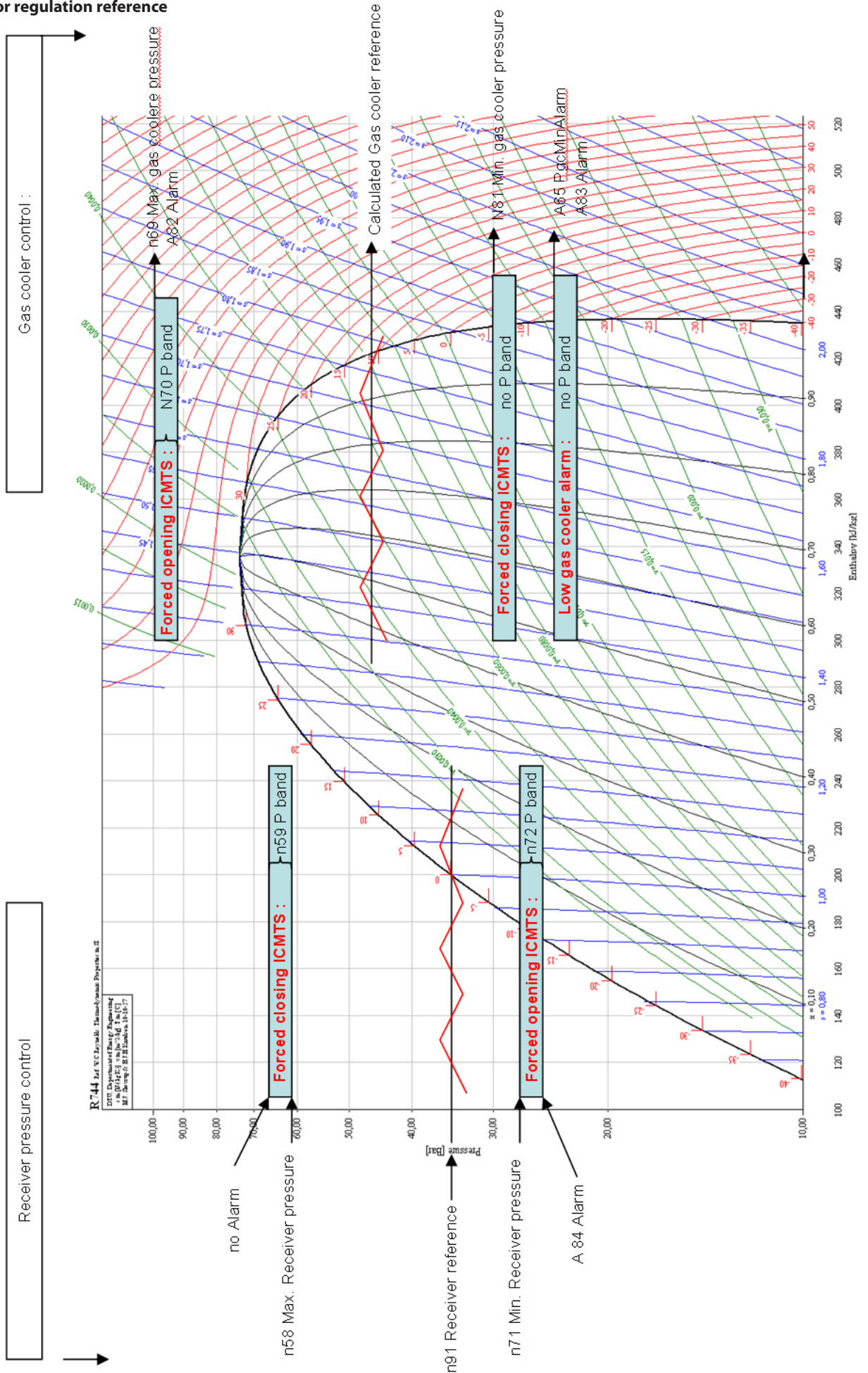

Valve function in alarm situations

| Error | Alarm message | ICMTS action (Vhp) | ETS action (Vgbb) |
|-------------------------------|-----------------------|---|---|
| EKC supply interrupted | none | EKC AO remains 0 V – ICMT closes if ICMTS has battery back-up | No change in opening degree |
| EKC Standby – Main Switch OFF | A45 – Standby mode | ICMTS closes | ETS closes to 'Vgbb OD Min' setting |
| Sgc2 interrupted | E15 – Sgc2 o.c. | ICMTS regulates with “Emergency cooling” | No change – ETS control attempts to maintain Prec |
| Sgc2 short circuited | E16 – Sgc2 s.c. | ICMTS regulates with “Emergency cooling” | No change – ETS control attempts to maintain Prec |
| Pgc transmitter error | E20 – Pgc input err | ICMTS regulates with “Emergency cooling” | No change – ETS control attempts to maintain Prec |
| Prec transmitter error | E39 – Prec input err | No change – ICMTS control continues | ETS regulates with “Emergency cooling” |
| StepMotor error | A43 – Step motor err | No change – ICMTS control continues | ETS closes to 'Vgbb OD Min' setting |
| Pgc Max limit exceeded | A82 – PgcMax alarm | No change – ICMTS control attempts to lower Pgc | No change – ETS control attempts to maintain Prec |
| Pgc Min limit exceeded | A83 – PgcMin alarm | No change – ICMTS control attempts to raise Pgc | No change – ETS control attempts to maintain Prec |
| Prec Min limit exceeded | A84 – PrecMin alarm | No change – ICMTS control attempts to maintain Pgc | No change – ETS control attempts to raise Prec |
| PgcRef Alarm | A94 – PgcRef alarm | No change – ICMTS control attempts to maintain Pgc | No change – ETS control attempts to raise Prec |
| PrecRef Alarm | A95 – PrecRef alarm | No change – ICMTS control attempts to maintain Pgc | No Change – ETS control attempts to raise Prec |
| EKC HW error | E1 – Controller fault | No change – ICMTS control continues | No change – ETS control continues |

“Emergency cooling”

The valve's average opening degree for the last six hours is regularly saved. This opening degree is used if there is a need for emergency cooling.

List of literature

- Instructions RI8NG (extract from this manual).
Here you can see how controllers are mounted and programmed.
- Installation guide for extended operation RC8AC
Here you can see how a data communication connection to ADAP-KOOL® Refrigeration control systems can be established.

Installation considerations

Accidental damage, poor installation, or site conditions, can give rise to malfunctions of the control system, and ultimately lead to a plant breakdown. Every possible safeguard is incorporated into our products to prevent this. However, a wrong installation, for example, could still present problems. Electronic controls are no substitute for normal, good engineering practice. Danfoss will not be responsible for any goods, or plant components, damaged as a result of the above defects. It is the installer's responsibility to check the installation thoroughly, and to fit the necessary safety devices.