

047C417

Montering - Mounting - Montage

mm (inch)

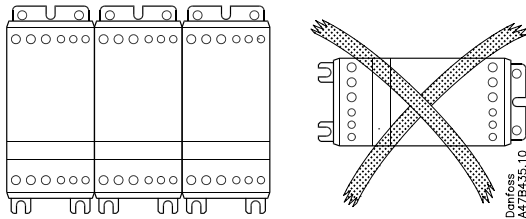
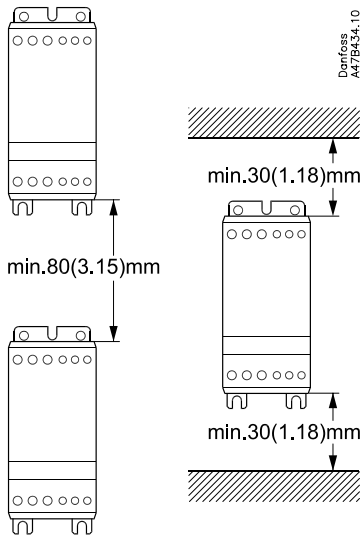

DK Hvis enhed er monteret vandret reducer strøm med 50%
 UK If unit is mounted horizontally derate current by 50%
 D Falls Einheit horizontal montiert wird, reduziert sich der Strom um 50%.

Forbindelse - Wiring - Verdrahtung

75°C Kabel/ wire*	 mm ² (AWG)	 mm ² (AWG)
	1.5 - 6 (16 - 10)	0.5 - 1.5 (20 - 16)
	2 x 1.5 - 6 (2 x 16 - 10)	2 x 0.5 - 0.75 (2 x 20 - 18)
	1.5 - 10 (16 - 8)	0.5 - 1.5 (20 - 16)
	2 x 1.5 - 6 (2 x 16 - 10)	2 x 0.5 - 1.5 (2 x 20 - 16)
	1.5 - 10 (16 - 8)	0.5 - 1.5 (20 - 16)
	2 x 1 - 6 (2 x 16 - 10)	2 x 0.5 - 1.5 (2 x 20 - 16)
	Pozidrive 2 1.2 Nm max. 10.6 lb-in max.	N.A.
	6 mm 1.2 Nm max. 10.6 lb-in max.	3 mm 0.5 Nm max. 4.4 lb-in max.

- **Vigtigt:** (Overhold max. skruedrejningsmomenter) * Use copper conductor only
- **Important:** (Observe the maximum screw torque limits)
- **Wichtig:** (Max. Drehmoment beachten)



C US
LISTED

UL: Use thermal overload protection as required by the National Electric Code
 Maximum surrounding temperature 40 °C.

047C0417

Mål - Dimensions - Abmessungen

mm (inch)

ECI 30

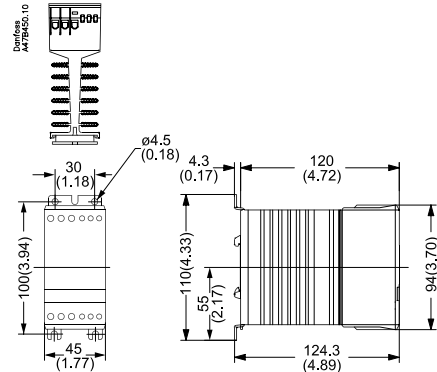

ECI 50

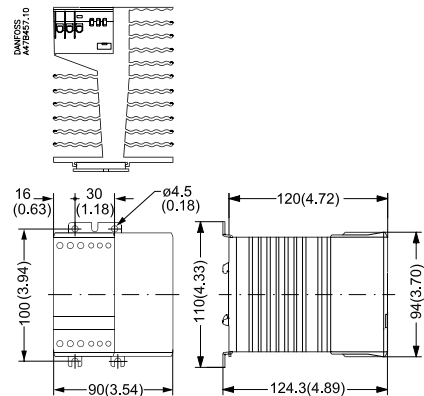

DK Køleplade skal holdes ren. Luftstrøm må ikke blokeres
 UK Keep heat sink clean. Airflow should not be blocked
 D Kühlflächen freihalten. Luftstrom muß ungehindert fließen

A1 - A2, A3 - A4

24-230V	5-24 V
037N0013 - N0018	037N0019 - N0024

