

Technical brochure

# Motor Valves and Actuators

## ICM 20-150 and ICAD 600-1200



ICM motor valves belong to the ICV (Industrial Control Valve) family and are one of two product groups.

*ICV types*

- ICS - Industrial Control Servo
- ICM - Industrial Control Motor

The motor valve comprises four main components: Valve body, top cover, function module and Actuator. On ICM 20-65 the top cover and function module are combined. ICM are direct operated motorized valves driven by actuator type ICAD (Industrial Control Actuator with Display).

ICM valves are designed to regulate an expansion process in liquid lines with or without phase change or control pressure or temperature in dry and wet suction lines and hot gas lines. ICM valves are designed so that the opening and closing forces are balanced, therefore, only three sizes of ICAD actuators are needed for the complete range of ICM from size 20 to 150 (3/4" to 6"). The ICM motorized valve and ICAD actuator assembly offers a very compact unit with small dimensions.

**Features (valve)**

- Low temperature direct-weld steel body.
- Low weight and compact design.
- V-port regulating cone ensures optimum regulating accuracy particularly at part load.
- Modular Concept
  - Each valve body is available with several different connection types and sizes.
  - Valve overhaul is performed by replacing the function module (ICM 20-65).
  - Possible to convert ICM motor valve to ICS servo valve.
  - Spare parts available for ICM 100-150.
- Manual opening possible via ICAD or Multi-function tool.
- PTFE seat provides excellent valve tightness.
- Magnet coupling - real hermetic sealing.

**Contents**

	<b>Page</b>
Introduction .....	3
The ICM Concept .....	4
Design (valve) .....	6
Technical data (valve) .....	6
Function (valve) .....	7
ICAD:	
Features (actuator) .....	8
Technical data (actuator) .....	8
Approvals .....	9
Function (actuator) .....	10
Operating the ICAD menu .....	10
Alarms .....	11
Parameter list .....	11
ICAD protection cap .....	13
ICAD-UPS for ICM 20-150 .....	14
Material specification .....	16
ICM Application .....	17
Nominal capacities:	
Expansion .....	18
Liquid line with/without phase change .....	24
Pumped Liquid line without phase change .....	28
Wet suction line .....	32
Dry suction line .....	36
Discharge line .....	40
Ordering:	
ICM 20 / ICAD 600 .....	44
ICM 25 / ICAD 600 .....	45
ICM 32 / ICAD 600 .....	46
ICM 40 / ICAD 900 / ICAD 1200 .....	47
ICM 50 / ICAD 900 / ICAD 1200 .....	48
ICM 65 / ICAD 900 / ICAD 1200 .....	49
ICM 100 - 150 / ICAD 1200 .....	50
Accessories:	
ICM / ICAD .....	51
Dimensions and weight .....	52
Connections .....	56

**Introduction**

The ICM motorized valve and ICAD actuator combinations are as follows:

Actuator	ICAD 600	ICAD 900/1200	ICAD 1200
Valve size	ICM 20	ICM 40	ICM 100
	ICM 25	ICM 50	ICM 125
	ICM 32	ICM 65	ICM 150

*ICAD 600 / ICAD 900 / ICAD 1200*

ICAD actuators can be controlled using the following signals:

- 0-20 mA
- 4-20 mA (default)
- 0-10 V
- 2-10 V
- Digital input for on/off function
- Two digital inputs for floating 3-point control (open - neutral - close)

ICAD actuators can also operate an ICM valve as an On/Off function supported by a digital input.

The ICM valve can be operated manually via the ICAD actuator or the Multi-function tool for ICM (see the ordering section).

*Fail Safe supply options*

In the event of a power failure, multiple fail safe options are possible, provided that a ICAD-UPS or similar is used.

During power failure, ICM can be selected to:

- Close ICM
  - Open ICM
  - Stay in the same position, as when power failure occurs
  - Go to a specific ICM valve opening degree
- See the section ICAD UPS for further information.

**Please note:** a fail safe supply (battery or UPS) is required.

**The ICM Concept**

The ICM concept is developed around a modular principle. This gives the possibility of combining function modules and top covers with special valve body size that is available in a variety of connection possibilities.

- There are nine valve bodies available.

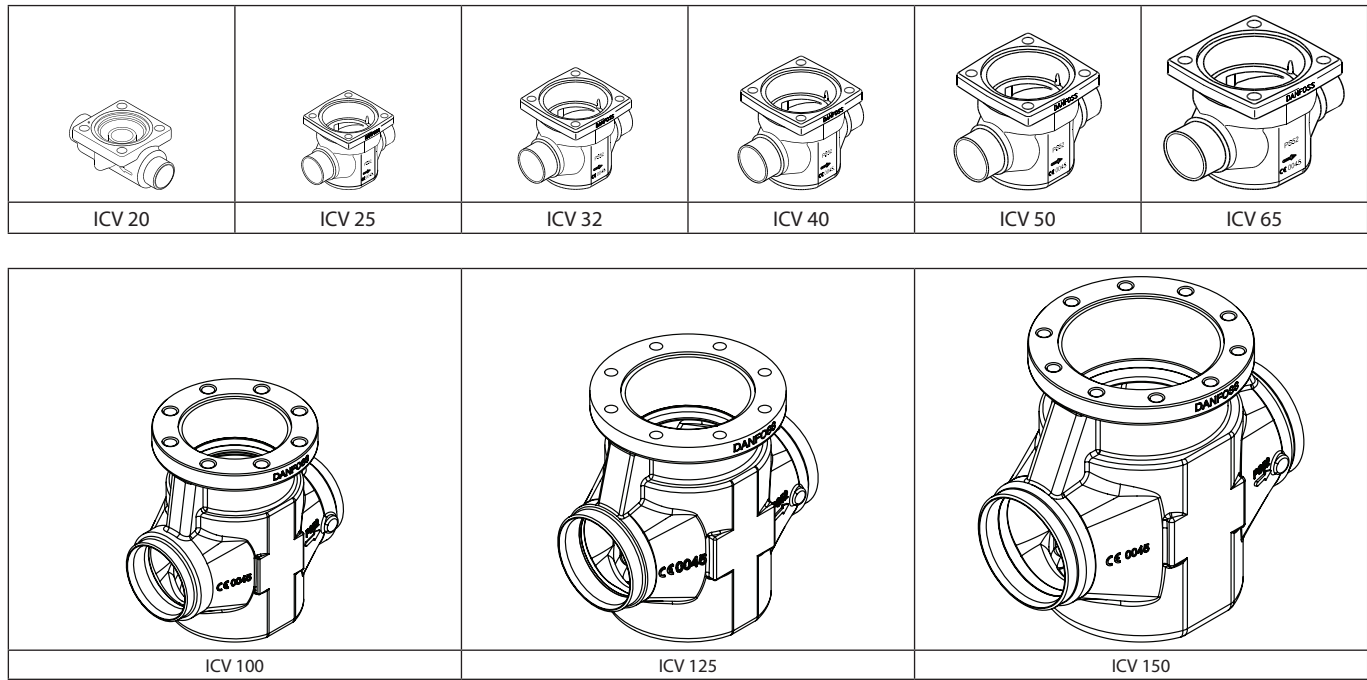

- Valve bodies in the sizes ICV 20-ICV65 are available with a range of undersizes through oversized connection sizes and types. ICV 100 - ICV 150 are available in butt-weld ANSI nominal sizes

A	SOC	SA	FPT
Butt-weld ANSI	Socket weld ANSI	Solder ANSI	Female Pipe Thread



**Motor valves, type ICM 20-150 and actuators type ICAD 600, 900 and 1200**

**The ICM Concept**  
(continued)

- Each body may be fitted with multiple function / top cover to give different capacities.

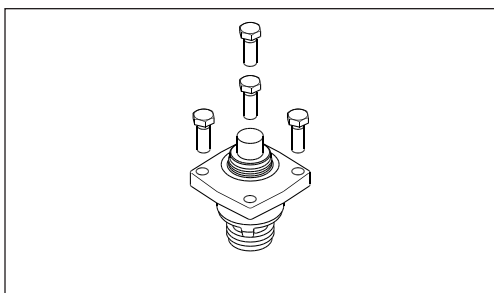

Type	Valve body size	$K_v$ (m <sup>3</sup> /h)	$C_v$ (USgal/min)
ICM20A-33	20	0.2	0.23
ICM 20-A		0.6	0.7
ICM 20-B		2.4	2.8
ICM 20-C		4.6	5.3
ICM 25-A	25	6	7.0
ICM 25-B		12	13.9
ICM 32-A	32	9	10.4
ICM 32-B		17	20
ICM 40-A	40	15	17
ICM 40-B		26	30
ICM 50-A	50	23	27
ICM 50-B		40	46
ICM 65-A	65	35	41
ICM 65-B		70	81
ICM 100-B	100	142	167
ICM 125-B	125	223	260
ICM 150-B	150	370	430

A magnetic coupled actuator is easily installed.  
Only three actuators are needed to cover the entire ICM program

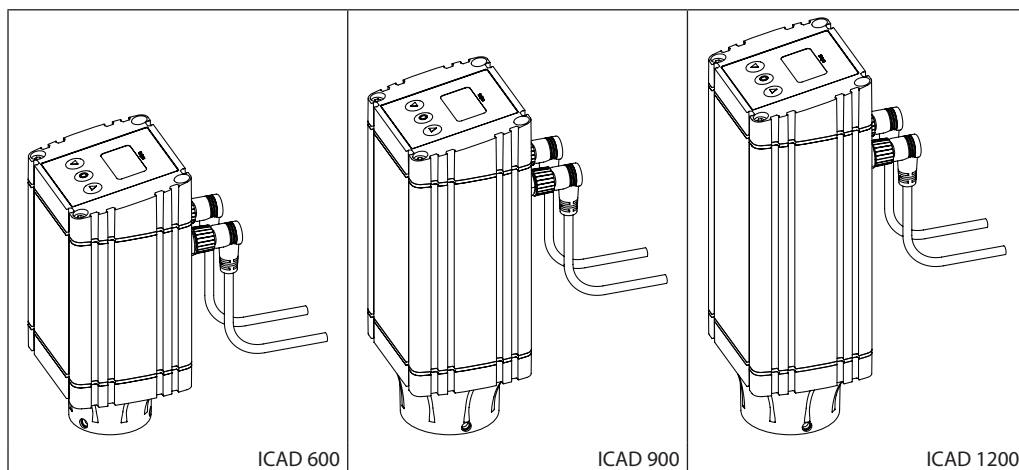

**Design (valve)**
*Connections*

There is a very wide range of connection types available with ICM valves:

- BW: Butt weld, ANSI (B 36.10)
- SOC: Socket weld, ANSI (B 16.11)
- ODS: Solder connection, ANSI (B 16.22)
- FPT: Female pipe thread (ANSI/ASME B 1.20.1)

*Approvals*

The ICV valve concept is designed to fulfil global refrigeration requirements.

ICM is CE, UL and CRN approved

For specific approval information, please contact Danfoss.

The ICM valves are approved in accordance with the European standard specified in the Pressure Equipment Directive and are CE marked.  
For further details / restrictions - see Installation Instruction.



ICM valves			
Nominal bore	DN ≤ 25 (1 in.)	DN 32-65 (1 1/4 - 2 1/2 in.)	DN 80-125 (3 - 5 in.)
Classified for	Fluid group I		
Category	Article 3, paragraph 3	II	III

**Technical data (valve)**
*Refrigerants*

Applicable to HCFC, HFC, R717 (Ammonia) and R744 (CO<sub>2</sub>).

Use with flammable hydrocarbons cannot be recommended. For further information please contact your local Danfoss sales company.

- *Temperature range:*  
Media: -60/+120°C (-76/+248°F).



When used in liquid refrigerant above +75°C (+167°F), please contact Danfoss

- *Pressure*  
The valve is designed for:  
Max. working pressure: 52 bar g (754 psi g)
- *Surface protection*  
ICM 20-150:  
The external surface is zinc-chromated to provide good corrosion protection.

- Max. opening pressure differential (MOPD)
  - ICM 20-32: 52 bar (750 psi)
  - ICM 40: 40 bar (580 psi)
  - ICM 50: 30 bar (435 psi)
  - ICM 65: 20 bar (290 psi)
  - ICM 100: 20 bar (290 psi)
  - ICM 125: 20 bar (290 psi)
  - ICM 150: 20 bar (290 psi)
- Time to move from Closed to Open position or in reverse order with maximum selected speed at ICAD.
  - ICM 20: 3 Sec. ICM 65: 13 Sec.
  - ICM 25: 7 Sec. ICM 100: 25 Sec.
  - ICM 32: 8 Sec. ICM 125: 35 Sec.
  - ICM 40: 10 Sec. ICM 150: 45 Sec.
  - ICM 50: 13 Sec.

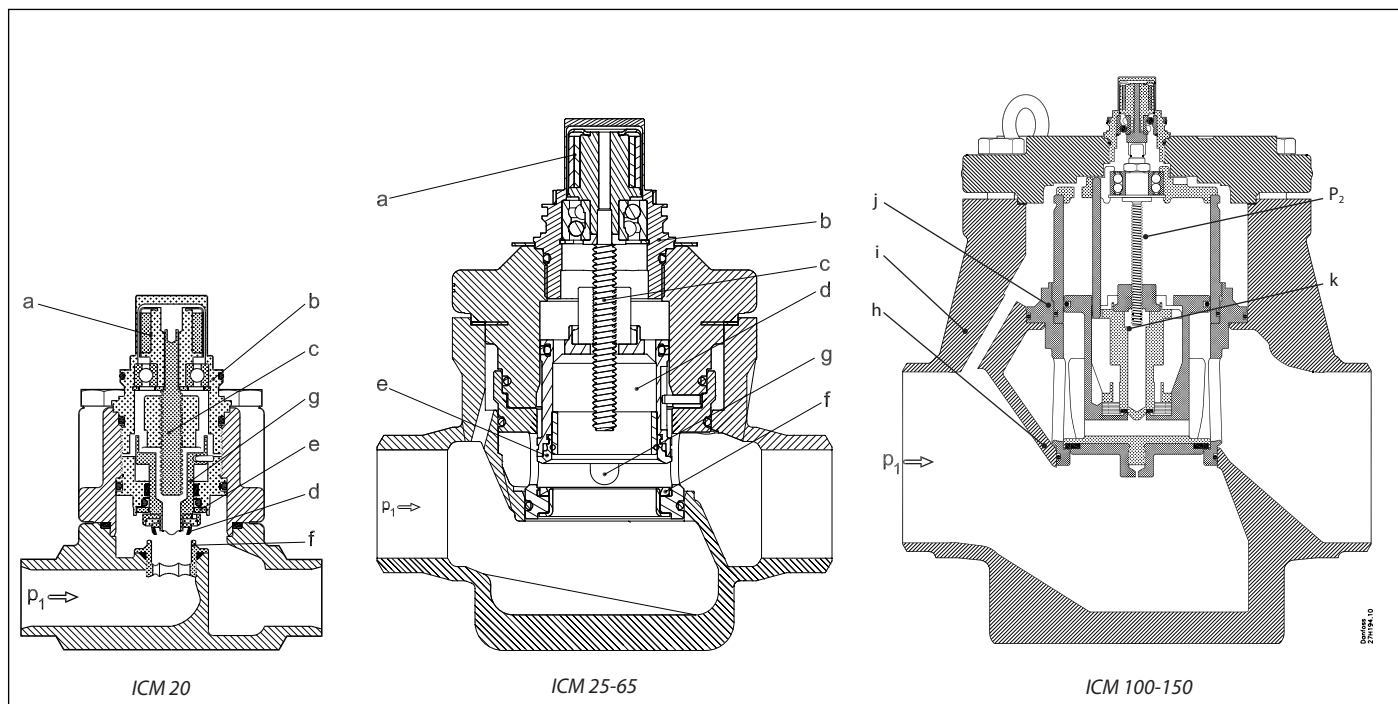
**Function (valve)**

ICM, Industrial Control Motor valves are designed for use with the ICAD, Industrial Control Actuator with Display.

The driving force from the actuator is transferred via a magnetic coupling (a) through the stainless steel top housing (b) and thus eliminates the need for a packing gland. The rotational movement of the magnetic coupling (a) is transferred to a spindle (c) which in turn provides the vertical movement of the piston (d) and the valve seat (e), to open and close the valve. The closing force of the actuator, combined with the valve seat (e) and PTFE valve plate (f), provides an effective seal to prevent leakage across the valve port, when the valve is in the closed position. To prevent damage to the PTFE valve seat (e) and plate (f) from system debris, it is recommended that a filter is installed upstream of the valve. Please refer to FIA filter / strainer literature for selection and ordering.

**ICM 20-65:**

Valve inlet pressure ( $P_1$ ) acting on the underside of the PTFE valve seat (e) also passes through the hollow piston assembly (d) on to the top of the piston (d) and balances the pressure acting on the piston (d). Any trapped liquid across the throttle cone (g) is allowed to equalise down to the valve outlet without affecting the valve performance.

**ICM 100-150:**

Valve inlet pressure ( $P_1$ ) acting on the underside of the PTFE valve plate (h) also passes through the equalization hole (i) and ensures that the servo piston (j) is pressure balanced. This will equalize  $P_1$  and  $P_2$ . During an opening operation of the valve, the pilot piston (k) will be raised from its valve seat inside the servo piston (j). This allows the  $P_2$  pressure to escape through the servo piston (j) to the outlet of the valve. The pressure  $P_1$  will act on the underside of the servo piston (j) and force it to open. This will close the gap between the pilot piston (k) and the servo piston (j) until the pressures  $P_1$  and  $P_2$  are equalized again. When there is no pressure difference between  $P_1$  and the outlet of the valve the pilot piston (k) is attached to the servo piston (j) ensuring it to open up.

**ICAD**

There are three sizes of ICAD actuator that covers the range of valves from ICM 20 to ICM 150. The actuators have a fully weather protected enclosure with none of the moving parts exposed to the environment.

The fast acting actuators and balanced valve design results in the valve being able to move from the fully closed to the fully open position in between 3 to 45 seconds depending on valve size and ICAD setup.

## ICAD

Actuator types ICAD 600, 900 and 1200 are dedicated for use with ICM motorized valves. There are only three sizes of ICAD actuators that cover the range of valves from ICM 20 to ICM 150.  
The ICAD is controlled via a modulating analogue signal (e.g. 4-20 mA/2-10 V) or a

digital ON/OFF signal. ICAD incorporates an advanced MMI (Man Machine Interface), including continuous display of Opening Degree, which gives the user a very advanced and flexible setup procedure that can meet many different applications.

### Features (actuator)

- Designed for industrial refrigeration installations.
- Advanced and high speed Digital Stepper Motor Technology
- Seven segment LCD display and three programming keys included
- Valve opening degree can be observed continuously.
- Can easily be configured to different applications on-site (change speed, ON/OFF, etc.)
- Modulating, ON/OFF operation
- Multiple speed selection during operation
- Logging of old alarms
- Password protection
- Control input signal : 4-20 mA, 0-20 mA, 0-10 V, 2-10 V, one or two digital inputs.
- Position feed back : 0-20 mA, 4-20 mA (ICM)
- 3 Digital outputs for feedback
- Resolution: 20 micron/step (0.02 mm stroke pr. step)
- Auto Calibration, Neutral zone
- In the event of a power failure, multiple fail safe options are possible. During power failure, ICM can be selected to:
  - Close ICM,
  - Open ICM,
  - Stay in the same position, as when power failure occurs
  - Go to a specific ICM valve opening degree
- Hermetic magnetic motor
- Enclosure: IP67 ~ NEMA 6
- ICAD 1200 ensures an accurate feedback on the valve position.

### Technical data (actuator)

ICAD 600, ICAD 900 and ICAD 1200 can be used together with following Danfoss valves.

ICAD 600	ICAD 900	ICAD 1200
ICM 20	ICM 40	ICM 40
ICM 25	ICM 50	ICM 50
ICM 32	ICM 65	ICM 65
		ICM 100
		ICM 125
		ICM 150

- *Materials*  
Housing  
Aluminium  
Top part of ICAD  
PBT thermo plastic
- *Weight*  
ICAD 600: 1.2 kg (2.64 lb)  
ICAD 900: 1.8 kg (3.96 lb)  
ICAD 1200: 1.9 kg (4.19 lb)
- *Temperature range (ambient)*  
-30°C/+50°C (-22°F/122°F)

*Enclosure*  
IP 67 (~NEMA 6)

*Cable connection*  
2 cable premounted of 1.5 m length (60 in.)

*Supply cable*  
3 × 0.34 mm<sup>2</sup> (3 × ~22 AWG)  
Ø4.8 mm (diameter 0.19")

*Control cable*  
7 × 0.25 mm<sup>2</sup> (7 × ~24 AWG)  
Ø6 mm (diameter 0.24")

### Electrical data

Supply voltage is galvanic isolated from Input/Output.

*Supply voltage:* 24 V d.c., + 10% / -15%  
*Load:* ICAD 600: 1.2 A  
ICAD 900: 2.0 A  
ICAD 1200: 3.0 A

*Fail safe supply:* Min. 19 V d.c, max. 26.4 V d.c.  
*Load:* ICAD 600: 1.2 A  
ICAD 900: 2.0 A  
ICAD 1200: 3.0 A

*Analogue Input* - Current or Voltage  
*Current:* 0/4-20 mA  
*Load:* 200 Ω  
*Voltage:* 0/2-10 V d.c  
*Load :* 10 kΩ

*Analogue Output:* 0/4-20 mA  
*Load :* ≤ 250 Ω

*Digital Input* - Digital ON/OFF input by means of volt-free contact (Signal/Telecom relays with gold-plated contacts recommended) – Voltage input used  
*ON:* Contact impedance < 50 Ω )  
*OFF:* Contact impedance > 100 kΩ

*Digital Output* - 3 pcs. NPN transistor output  
*External supply:* 5-24 V d.c.  
(Same supply as for ICAD can be used, but please note that the galvanically isolated system will then be spoiled)

*Output load:* 50 Ω  
*Load:* Max. 50 mA

**Motor valves, type ICM 20-150 and actuators type ICAD 600, 900 and 1200**
**Technical data (cont.)**
*Electrical data*
*Battery capacity:  
For each open/closed cycle*

	Speed Parameter i04	ICM 20	ICM 25	ICM 32
<b>ICAD 600</b>	Max. (i04 = 100)	2 mAh	5 mAh	5 mAh
	Min. (i04 = 1)	200 mAh	467 mAh	533 mAh
	Speed Parameter i04	ICM 40	ICM 50	ICM 65
<b>ICAD 900</b>	Max. (i04 = 100)	11 mAh	15 mAh	15 mAh
	Min. (i04 = 1)	1111 mAh	1445 mAh	1445 mAh
<b>ICAD 1200</b>	Max. (i04 = 100)	17 mAh	22 mAh	22 mAh
	Min. (i04 = 1)	1667 mAh	2167 mAh	2167 mAh
	Speed Parameter i04	ICM 100	ICM 125	ICM 150
<b>ICAD 1200</b>	Max. (i04 = 100)	54 mAh	65 mAh	76 mAh
	Min. (i04 = 1)	5318 mAh	6351 mAh	7501 mAh

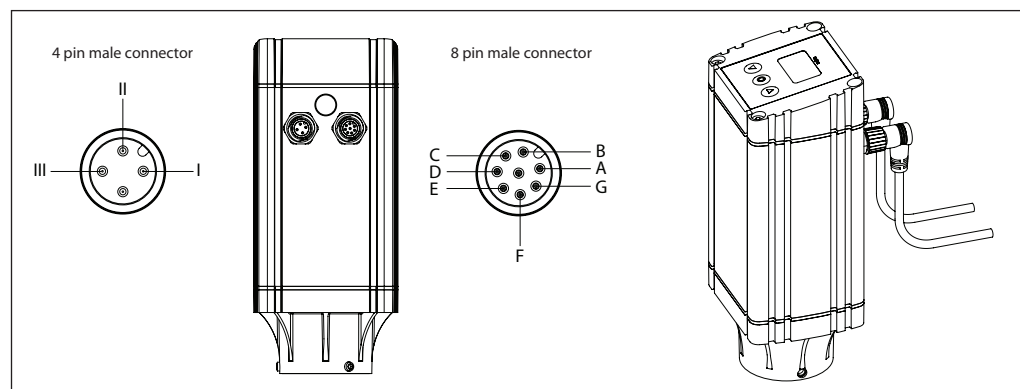
*Cable connections*

**Communication connector / cable**

Ref.	Color		Description
A	Black	-	Common Alarm
B	Brown	-	ICM fully open
C	Red	-	ICM fully closed
D	Orange	-	GND ground
E	Yellow	+	0/4 - 20 mA Input*
F	Green	+	0/2 - 10 V Input. Also used with GND (orange wire) as a digital input #1 for on-off operation or floating 3-point control
G	Blue	+	0/4 - 20 mA Output*

} Digital Output

**Power connector/cable (3 wires)**

I	Black	+	Fail safe supply Battery / UPS (uninterruptable power supply) 19 V d.c.
II	White	+	Supply voltage
III	Brown	-	24 V d.c.

\* If using floating 3-point control (parameter i02=3) then wire colors yellow and blue are combined to make the 2nd digital input

**Approvals**

 CE according to 89/336 EEC (EMC)  
Emission : EN61000-6-3  
Immunity:EN61000-6-2

**Function (actuator)**

The design of ICAD is based on a digital stepper motor technology combined with an advanced MMI (Man Machine Interface), that gives excellent possibilities for having a high degree of flexibility with the same type of ICAD actuator.

The ICAD display will continuously display the ICM valve opening degree in % unless there is an alarm or the parameter list is being viewed. The display will also indicate **Mod** if being controlled by an analog input signal (modulating mode) or if being controlled by digital inputs the display will indicate **Low**, **Med** or **High** depending on the speed setting.

The advanced menu system will allow several parameters to be adjusted to obtain the required function. Among these are:

- Analog input for modulating control  
0- 20 mA or 4-20 mA  
0-10 V or 2-10 V
- Digital Inputs  
ICAD can be configured to support one or two digital inputs.  
When using one digital input for on/off control, 0-10 V can not be used at the same time.  
When using two digital inputs for floating 3 point control, the analog input (0/2-10 V, 0/4-20 mA) and Analog Output (0/4-20 mA) can not be used at the same time.
- Analog output  
0- 20 mA or 4-20 mA
- Automatic or manual control

- Change of ICM valve speed
- Automatic calibration
- Multiple Fail Safe set-up options during power cut

A password protection has been linked to the parameter of entering the correct ICM valve to avoid unintentional and non-authorized operation.

ICAD can manage and display different alarms. If an alarm has been detected the display will alternate between showing: Actual alarm present and Opening Degree of ICM valve. If more than one alarm is active at the same time the alarm with the highest priority will take preference. The alarm with the highest priority is shown on the display.

All alarms will automatically reset when disappearing.

Previous alarms can be recalled for traceability and service purposes.

Any active alarm will activate the common digital alarm output.

ICAD provides two digital output signals to 3rd party control equipment (e.g. PLC) indicating if the ICM valve is completely open or completely closed.

**Operating the ICAD menu**

1. To access the ICAD actuator menu, press and hold the middle button (2) until the menu appears.

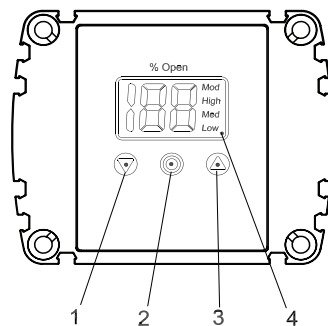

1. Down arrow push button
2. Enter
3. Up arrow push button
4. Display

2. Once you are in the menu, use the UP (3) and DOWN (1) arrows to move through the list of parameters.
3. To display and/or change the value of the parameter, press the middle button (2) to view the current settings.
4. a) To change the value of a parameter, use the up or down arrow to establish the new value for that parameter.
5. b) Once the new value for the parameter has been selected, press the middle button to save the change and return to the menu.
6. Repeat this procedure for all parameters.
7. Exit from the parameter list by pressing and holding the middle button for 2 seconds or simply wait for the ICAD to return to the main display (approx. 20 seconds).

## Motor valves, type ICM 20-150 and actuators type ICAD 600, 900 and 1200

### Alarms

ICAD can handle and display different alarms.

Description	ICAD alarm text	Definition of event	Comments
No Valve type selected	<b>A1</b>	Alarm ON	At start-up <b>A1</b> will be displayed until parameter <b>j26</b> is set
Controller fault	<b>A2</b>	Alarm ON	Internal fault inside electronics. Carry out: 1) Power OFF and Power ON If <b>A2</b> still active. 2) Make a Reset to factory setting If <b>A2</b> still active. Return ICAD to Danfoss
Analog input error	<b>A3</b>	Alarm ON	Not active if <b>j01</b> = 2, or <b>j02</b> = 2 When <b>j03</b> = 1 and AI A > 22 mA When <b>j03</b> = 2 and AI A > 22 mA or AI A < 2 mA When <b>j03</b> = 3 and AI A > 12 V When <b>j03</b> = 4 and AI A > 12 V or AI A < 1 V
Low voltage of fail safe Supply	<b>A4</b>	Alarm ON	If 5 V < fail safe supply < 18 V. Enabled by <b>j08</b>
Check supply to ICAD	<b>A5</b>	Alarm ON	If supply voltage < 18 V
Calibration extended failed	<b>A6</b>	Alarm ON	Check valve type selected. Check presence of foreign debris inside ICM valve
Thermal overload	<b>A8</b>	Alarm ON	ICAD stepper motor temperature too high
Valve locked	<b>A9</b>	Alarm ON	Only active if <b>i16</b> = 1 If the ICM valve is locked for more than 15 seconds (unable to reach its requested position) <b>A9</b> will flash in display. <b>A9</b> alarm can only be reset by Power OFF/ON of ICAD

If an alarm has been detected the ICAD display (fig. 2) will alternate between showing actual alarm and present Opening Degree.

If more than one alarm is active at the same time the alarm with the highest priority will take preference. **A1** has the highest priority, **A9** the lowest.

Any active alarm will activate the Common Digital Alarm output (Normally Open).

All alarms will automatically reset them-selves when they physically disappear.

Old alarms (alarms that have been active, but have physically disappeared again) can be found in parameter **j11**.

### Parameter list - Valid for software versions i58=9 and parameter i59=18 and onwards

Description	ICAD parameter	Min	Max	Factory Setting	Setting stored	Pass word	Comments
OD (Opening degree)	-	0	100			-	ICM valve Opening Degree in % is displayed during normal operation. Running display value (see <b>j01</b> , <b>j05</b> ).
Main switch for manual operation	<b>j01</b>	1	2	1	Yes	No	Internal main switch 1: Normal operation 2: Manual operation. Valve Opening Degree will be flashing. With the down arrow and the up arrow push buttons the OD can be entered manually.
Operation mode	<b>j02</b>	1	2	1	Yes	No	Operation mode 1: Modulating – ICM positioning according to Analog Input (see <b>j03</b> ) 2: ON/OFF - operating the ICM valve like an ON/OFF solenoid valve controlled via Digital Input. See also <b>j09</b> . 3: Neutralzone / 3 point control. Increase/Decrease Opening Degree by Digital Input. See ICAD instructions for wiring diagram
Analog input signal	<b>j03</b>	1	4	2	Yes	No	Type of AI signal from external controller 1: 0-20 mA 2: 4-20 mA 3: 0-10 V 4: 2-10 V
Speed In <b>Modulating Mode</b> Opening/closing speed In <b>ON/OFF Mode</b> Opening speed	<b>j04</b>	1	100	50/ 100	Yes	No	Speed can be set in % of full speed. Max. speed is 100 % - Not active in manual operation ( <b>j01</b> = 2) If <b>j26</b> = 1 - 3 then factory setting =100 If <b>j26</b> = 4 - 9 then factory setting =50 If ICM is opening and ( <b>j04</b> <= 33) or ICM is closing and ( <b>j14</b> <= 33) => Low is displayed. If ICM is opening and (33 < <b>j04</b> <= 66) or ICM is closing and (33 < <b>j14</b> <= 66) => Med is displayed. If ICM is opening and ( <b>j04</b> >= 67) or ICM is closing and ( <b>j14</b> >= 67) => High is displayed
Automatic calibration	<b>j05</b>	0	2	0	No	No	Not active before <b>j26</b> has been operated. Always resets to 0 after calibration. CA will flash in the display during calibration, if Enter push button has been activated for two seconds 0: No Calibration 1: Normal forced calibration - CA flashing slowly 2: Extended calibration – CA flashing rapidly

to be continued ...



**Motor valves, type ICM 20-150 and actuators type ICAD 600, 900 and 1200**

Description	ICAD parameter	Min	Max	Factory Setting	Setting stored	Pass word	Comments
Analog output signal	<b>i06</b>	0	2	2	Yes	No	Type of A0 signal for ICM valve position 0: No signal 1: 0-20 mA 2: 4-20 mA
Failsafe	<b>i07</b>	1	4	1	Yes	No	Define condition at power cut and fail safe supply is installed. 1: Close valve 2: Open Valve 3: Maintain valve position 4: Go to OD given by <b>i12</b> "
Fail safe supply	<b>i08</b>	0	1	0	Yes	Yes	Fail safe supply connected and enable of A4 alarm: 0: No 1: Yes
DI function for on/off operation	<b>i09</b>	1	2	1	Yes	No	Define function when DI is ON (short circuited DI terminals) when <b>i02</b> = 2 1: Open ICM valve (DI = OFF => Close ICM valve) 2: Close ICM valve (DI = OFF => Open ICM valve)
Password	<b>i10</b>	0	199	0	No	-	Enter number to access password protected parameters: <b>i26</b> Password = 11
Old Alarms	<b>i11</b>	A1	A99	-	No	No	Old alarms will be listed with the latest shown first. Alarm list can be reset by means of activating down arrow and up arrow at the same time for 2 seconds.
OD at power cut.	<b>i12</b>	0	100	50	Yes	No	Only active if <b>i07</b> = 4 If fail safe supply is connected and power cut occurs, the ICM will go to the specified OD.
Inverse operation	<b>i13</b>	0	1	0	Yes	No	When <b>i02</b> = 1 0: Increasing Analog Input signal => Increasing ICM Opening Degree 1: Increasing Analog Input signal => Decreasing ICM Opening Degree When <b>i02</b> = 3 0: DI1 = ON, DI2 = OFF => Increasing ICM Opening Degree. DI1 = OFF, DI2 = ON => Decreasing ICM Opening Degree DI1 = DI2 = OFF => ICAD/ICM maintain current position DI1 = DI2 = ON => ICAD/ICM maintain current position 1: DI1 = ON, DI2 = OFF => Decreasing ICM Opening Degree DI1 = OFF, DI2 = ON => Increasing ICM Opening Degree DI1 = DI2 = OFF => ICAD/ICM maintain current position DI1 = DI2 = ON => ICAD/ICM maintain current position
In <b>ON/OFF Mode</b> Closing speed	<b>i14</b>	0	100	50/ 100	Yes	No	See <b>i04</b> . If <b>i26</b> = 1 - 3 then factory settin qg = 100 If <b>i26</b> = 4 - 9 then factory setting = 50
Manual mode OD	<b>i15</b>	0	100	0	No	No	When <b>i01</b> = 2, <b>i15</b> is initial OD % when put in manual mode.
Encoder operation (only valid for ICAD 1200)	<b>i16</b>	0	1	0/1	Yes	Yes	<b>Note:</b> Password protected. Password = 7 If <b>i26</b> = 1 - 3 then factory setting = 0 If <b>i26</b> = 4 - 6 then factory setting = 0 (1 if ICAD1200) If <b>i26</b> = 7 - 9 then factory setting = 1 0: Encoder disabled. Means ICAD operates as ICAD 600/900 1: Encoder enabled
ICM configuration	<b>i26</b>	0	9	0	Yes	Yes	<b>Note:</b> Password protected. Password = 11 (see parameter <b>i10</b> ) 0: No valve selected. Alarm A1 will become active. 1: ICM 20 with ICAD 600 2: ICM 25 with ICAD 600 3: ICM 32 with ICAD 600 4: ICM 40 with ICAD 900/1200 5: ICM 50 with ICAD 900/1200 6: ICM 65 with ICAD 900/1200 7: ICM 100 with ICAD 1200 8: ICM 125 with ICAD 1200 9: ICM 150 with ICAD 1200



## Motor valves, type ICM 20-150 and actuators type ICAD 600, 900 and 1200

### Service parameters (view only)

Description	ICAD parameter	Min	Max	Unit	Comments
OD %	j50	0	100	%	ICM valve Opening Degree
AI [mA]	j51	0	100	mA	Analog input signal
AI [V]	j52	0	100	V	Analog input signal
AO [mA]	j53	0	100	mA	Analog output signal
DI Digital input Status	j54	0	1	-	DI signals. Depending of j02 If j02 = 2, one digit is shown. 0 : DI1 = OFF 1 : DI1 = ON  If j02 = 3, two digits are shown. 00 : DI1 = OFF, DI2 = OFF 10 : DI1 = ON, DI2 = OFF 01 : DI1 = OFF, DI2 = ON 11 : DI1 = ON, DI2 = ON
DO Status for ICM closed	j55	0	1	-	1: DO = ON when OD < 3 %; 0: DO = OFF
DO status for ICM opened	j56	0	1	-	1: DO = ON when OD > 97 % 0: DO = OFF
DO Alarm status	j57	0	1	-	1: DO = ON when a Alarm is detected 0: DO = OFF
Display mP SW ver.	j58	0	100	-	Software version for display microprocessor
Motor mP SW ver.	j59	0	100	-	Software version for motor microprocessor

### Reset to factory setting :

1. Remove the power supply.
2. Activate down arrow and up arrow push buttons at the same time.
3. Connect the power supply.
4. Release down arrow and up arrow push buttons.
5. When the display on ICAD is alternating between showing: **CA** and **A1** the factory resetting is complete.

### ICAD protection cap

For all outdoor applications or where extra protection of the display and keyboard is needed, Danfoss recommends using the ICAD protection cap.

The protection cap will give the ICAD display and keyboard an extra protection against e.g. sun radiation or other impacts from the surrounding environment. Furthermore it protects the cable connectors against inappropriate loads.

The special designed protection cap can be mounted on all ICAD 600/900/1200.

The installation of the protection cap is done by sliding the protection cap down on the top of the ICAD. To secure the protection cap, tie it to the connector cables using the hole in the protection cap.

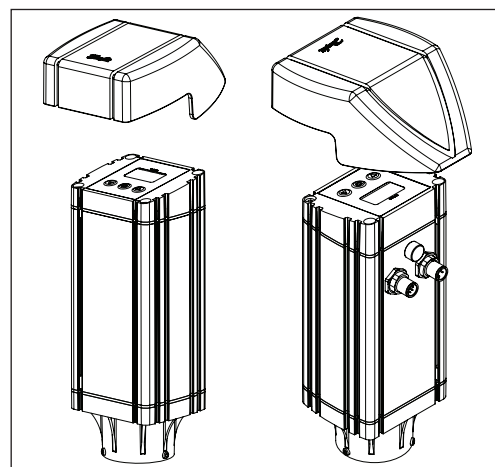
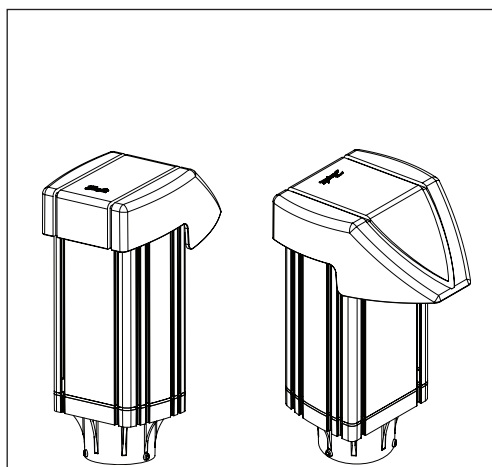

ICAD-UPS for ICM 20-150



ICAD-UPS is dedicated for use along with ICM sizes 20 - 150 installed with ICAD 600, ICAD 900 and ICAD 1200 actuators.

In the event of power failure, there is a need to make sure that the ICM goes to a safe position.

ICAD-UPS can be connected to the ICAD 600/900/1200.

The solution ICM with ICAD connected to ICAD-UPS will give one of the following possibilities in the event of power failure:

- close ICM
- open ICM
- stay
- go to a specific ICM Opening Degree

When power supply has been re-established the system will automatically return to normal operation.

Facts and features

- Industrial product.
- Can support up to
  - 3 pcs. of ICAD 1200 or
  - 5 pcs. of ICAD 900 or
  - 8 pcs. of ICAD 600
- Integrated solution - battery and UPS.
- Industrial approvals: CE, UL, GL (Germanischer Lloyd).
- DIN rail mounting.
- LED indication
  - Green (Power ON)
  - Yellow (Flashing:charging, Constant: Buffer mode (Failsafe supply to ICAD))
  - Red (Battery fully discharged/Battery faulty)
- 24 V d.c supply → Same transformer as for ICAD can be used. Only +0,5 A extra load on the transformer.
- Check of battery every 60 sec.
- Adjustable buffer time\*. (1, 2, 3, 5, 10, 15, 20, 30 or infinity) = Ensures longer life time of the battery.
- Forced remote shutdown in buffer mode via digital input.
- 3 digital volt free relay change over contacts for signals to PLC systems. (Power OK, Buffer mode (failsafe supply to ICAD), Alarm).

\* Buffer time is defined as the period where ICAD is only powered from the ICAD-UPS (i.e. not from main supply). On ICAD-UPS there is an adjustable buffer time setting (1, 2, 3, 5, 10, 15, 20, 30 min. or infinity). If set to 3, ICAD-UPS will switch off power to connected ICAD 600/900/1200, 3 minutes after the power failure occurs. This ensures that the internal battery inside ICAD-UPS do not fully discharge.

Code number: **027H0182**

For further information please see the instruction PIHV0B.

ICAD-UPS applications

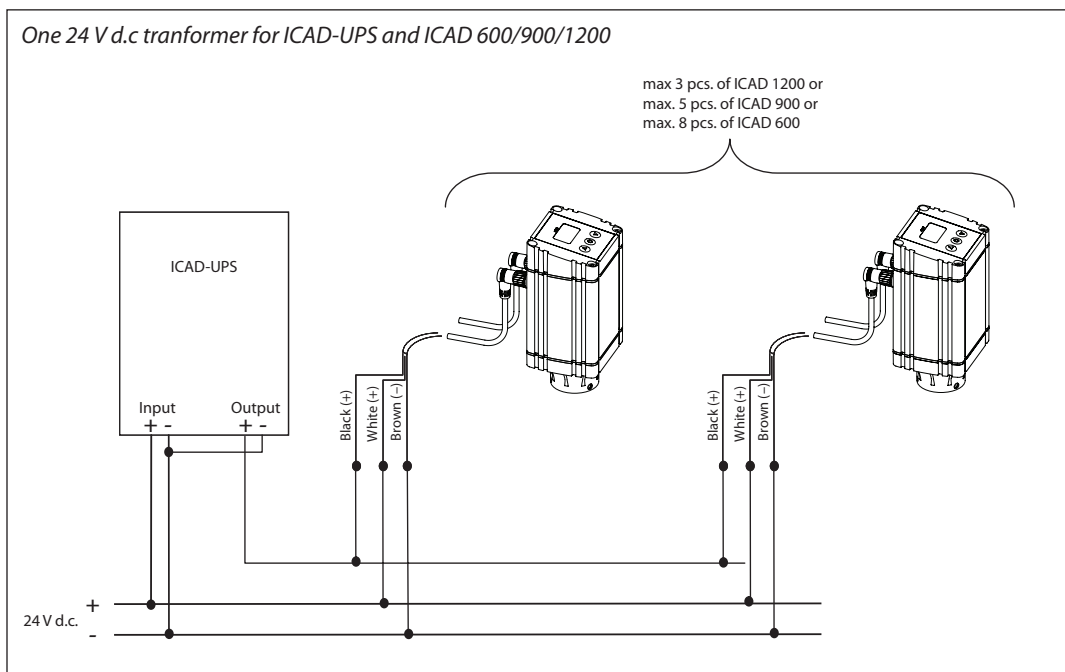
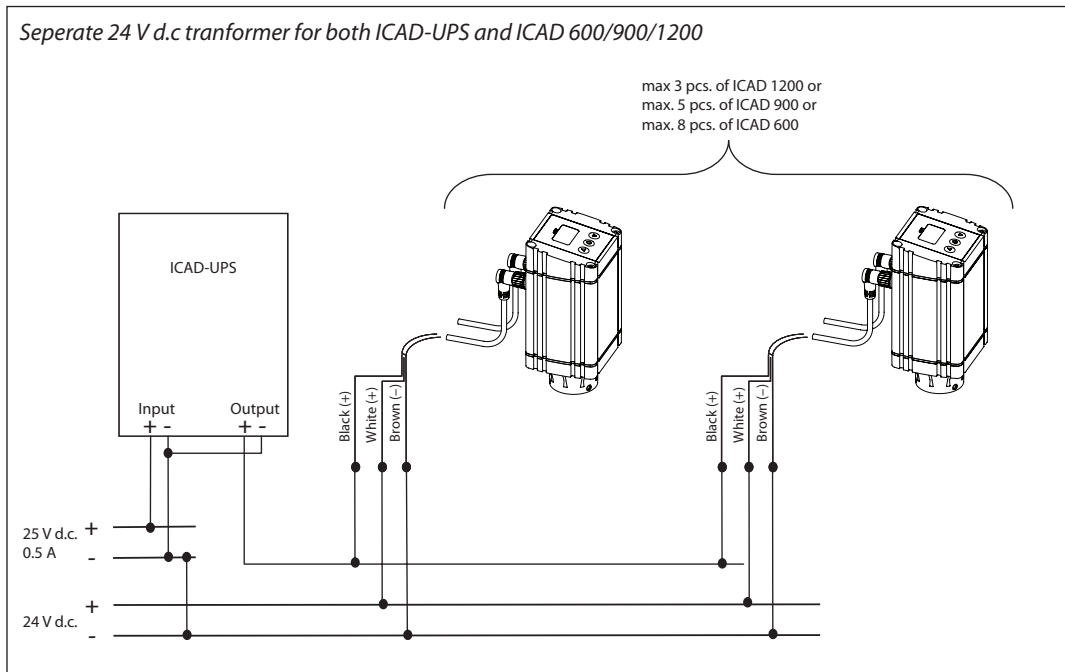

Material specification

ICM 20                      ICM 25-65

ICM 100-150

**Bolt sizes (pos. 5)**

Type	Screw
ICM 20	M10 × 55 A2-70 DIN 931
ICM 25	M12 × 30 A2-70 DIN 933
ICM 32	M14 × 35 A2-70 DIN 933
ICM 40	M14 × 35 A2-70 DIN 933
ICM 50	M16 × 40 A2-70 DIN 933
ICM 65	M16 × 40 A2-70 DIN 933

**Bolt sizes (pos. 5)**

Type	Screw
ICM 100	M20 × 60 A2-70 DIN 933
ICM 125	M20 × 60 A2-70 DIN 933
ICM 150	M20 × 70 A2-70 DIN 933

No.	Part	Material	EN	ASTM	JIS
1	Housing	Low temperature steel	G20Mn5QT, EN 10213-3	LCC, A352	SCPL1, G5151
2	Top cover	Low temperature steel	G20Mn5QT, EN 10213-3	LCC, A352	SCPL1, G5151
2a	O-ring	Cloroprene (Neoprene)			
2b	O-ring	Cloroprene (Neoprene)			
2c	O-ring	Cloroprene (Neoprene)			
3	Function module				
4	Gasket	Cloroprene (Neoprene)			
4a	Gasket	Fiber, non-asbestos			
5	Bolts	Stainless steel	A2-70, EN 1515-1	Grade B8 A320	A2-70, B 1054
11	Actuator				
12	O-ring	Cloroprene (Neoprene)			
13	O-ring	Cloroprene (Neoprene)			
14	Seat	High density polymer			

ICM Application

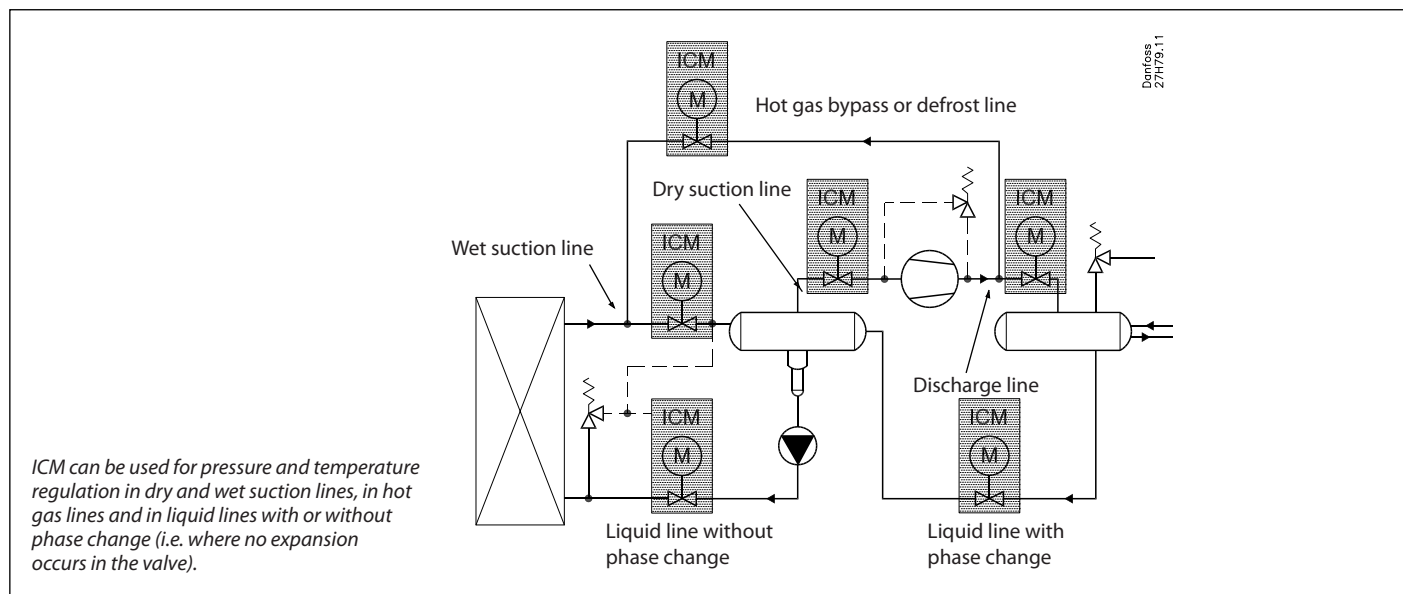

Valve capacities for different refrigerants and applications are given in the following tables. Selection of ICM / ICS valves will be available with the DIRcalc selection program. The resultant valve selections will be:- ICM-EXP for expansion valve functions and where the selection criteria has been predefined for expansion valve application: ICM will be for control valve functions and will include for all available function modules as valve pressure drop is the main consideration for valve selection.

The process for identifying the ICM valve solution can be determined from the ordering pages. Initially select the nominal valve size, identify the required valve body and connection types, followed by the module insert and then the correct actuator to suit the module insert and valve body.

As the ICM and ICS valves use a common body it is possible to install the body without having previously determined whether a servo or motor function is required. A blank top cover complete with fixing screws can be supplied to allow for pressure testing.

In applications where the ICM is used to control pressure/temperature at differing operating conditions e.g. dual temperature store, the ICM must be selected so that the full operating conditions (minimum and maximum capacity / summer and winter conditions) are within the control range of the selected ICM valve.

It is particularly important to ensure that the ICM valve selection is not oversized and as a consequence operates at a minimum opening degree, which can result in a hunting condition and continuous recalibration of the ICM valve.

**Note:**  
ICM valves should be sized to suit required capacity and operating conditions. ICM valves should not be line sized.

For ICM 20-65 applications it is recommended that the valve opening degree at the minimum operating conditions is greater than 5%.

For ICM 100-150 applications it is recommended that the valve opening degree at the minimum operating conditions is greater than 10%.

Nominal capacities

## Expansion/Liquid Make-up Applications

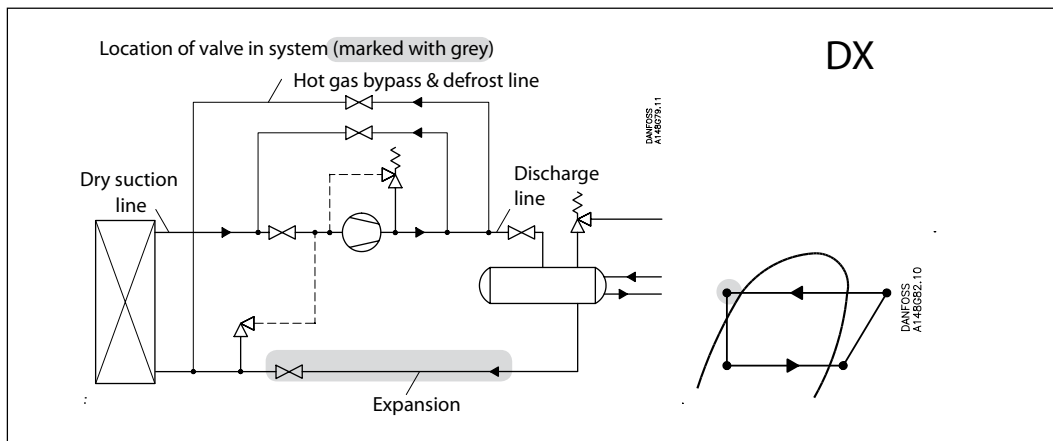
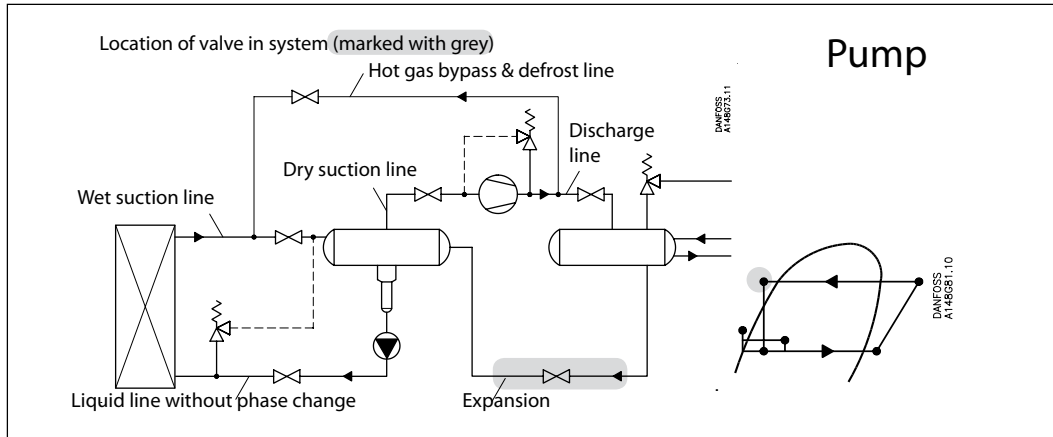

**Correction factors**

When dimensioning, multiply the evaporator capacity by a correction factor for subcooling  $k$  dependent on the subcooling  $\Delta t_{sub}$  just ahead of the valve. The corrected capacity\* can then be found in the capacity table.

**Correction factors for subcooling**

Subcooling °F	3.6	7.2	18	27	36	45	54	63	72
R717	1.01	1	0.98	0.96	0.94	0.92	0.91	0.89	0.87
R744	1.02	1	0.95	0.90	0.86	0.82	0.79	0.75	0.73
R134a	1.03	1	0.93	0.88	0.84	0.80	0.76	0.73	0.70
R404A	1.04	1	0.91	0.83	0.78	0.73	0.68	0.65	0.61
R22	1.03	1	0.94	0.90	0.87	0.83	0.80	0.77	0.74

\* The capacity table is based on nominal conditions of subcooling just ahead of the valve of 7.2°F.

**Calculation example:**

An application has the following operating conditions:

Refrigerant R717  
 $T_e = +20^\circ\text{F}$   
 $T_c = +85^\circ\text{F}$   
 $Q_0 = 426 \text{ TR}$   
 $\Delta t_{sub} = 36^\circ\text{F}$

Correction factor for subcooling: 0.94

Pressure drop across the valve:  
 $167 \text{ psig} - 48 \text{ psig} = 119 \text{ psi}$

Corrected capacity:  $426 \times 0.94 = 400 \text{ TR}$   
 From the R717 capacity table ICM 20-C is selected with  $Q_{nom}$  capacity 574 TR at 120 psi.

Note: It is common to select a valve with a least 15% additional capacity for superheat control and at least 25% additional capacity for liquid level control applications.

**Selection tables for expansion/liquid make-up applications**
*Capacities for nominal conditions,  $Q_n$  (TR)*
**R 717**

Type	Cv	Pressure drop across valve $\Delta p$ psi					
		15	30	60	120	180	240

Pressure drop across valve $\Delta p$ psi						
15	30	60	120	180	240	

**Evaporating temperature 60°F**

ICM20-A33	0.2	8.1	11.2	15.3	20.4	23.8	26.3
ICM20-A	0.7	24.5	33.9	46.3	61.8	72	79.3
ICM20-B	2.8	142	196	265	352	410	451
ICM20-C	5.3	235	321	432	570	660	730
ICM25-A	7	363	497	670	880	1025	1130
ICM32-A	10	523	720	970	1280	1490	1645
ICM40-A	17	975	1325	1780	2330	2705	3000
ICM50-A	27	1695	2310	3070	4030	4690	5170
ICM65-A	41	2790	3789	5061	6643	7708	8517

**Evaporating temperature 40°F**

8.4	11.6	15.8	20.9	24.2	26.7	
25.3	35	47.6	63	73	80.4	
147	201	271	358	415	458	
243	328	438	574	665	735	
375	510	680	888	1030	1140	
539	735	985	1294	1500	1655	
1000	1350	1800	2344	2715	3010	
1745	2350	3100	4050	4700	5200	
2863	3852	5104	6671	7736	8545	

**Evaporating temperature 20°F**

ICM20-A33	0.2	8.7	12	16.2	21.2	24.5	26.9
ICM20-A	0.7	26.3	36.2	48.8	64	74	81.4
ICM20-B	2.8	151	206	275	360	416	459
ICM20-C	5.3	248	332	439	574	665	734
ICM25-A	7	383	515	681	888	1030	1135
ICM32-A	10	553	746	993	1299	1510	1657
ICM40-A	17	1020	1360	1795	2346	2715	3005
ICM50-A	27	1770	2350	3100	4040	4680	5170
ICM65-A	41	2907	3862	5089	6647	7711	8518

**Evaporating temperature 0°F**

9	12.3	16.4	21.4	24.6	26.9	
27.1	37	49.5	64.5	74.3	81.5	
154	207	276	360	416	458	
249	330	435	570	660	728	
385	513	678	884	1025	1130	
560	747	990	1293	1500	1650	
1022	1345	1775	2325	2700	2970	
1770	2320	3050	4000	4650	5130	
2895	3812	5019	6576	7639	8446	

**Evaporating temperature -20°F**

ICM20-A33	0.2	9.2	12.5	16.6	21.4	24.6	26.8
ICM20-A	0.7	27.7	37.5	50	64.5	74	81
ICM20-B	2.8	154	206	274	357	413	454
ICM20-C	5.3	244	323	428	560	653	720
ICM25-A	7	380	503	665	875	1015	1120
ICM32-A	10	555	740	978	1285	1485	1635
ICM40-A	17	995	1315	1740	2290	2660	2945
ICM50-A	27	1720	2255	2985	3930	4570	5050
ICM65-A	41	2817	3712	4921	6481	7539	8338

**Evaporating temperature -40°F**

9.3	12.6	16.6	21.3	24.4	26.6	
28	37.8	50	64.3	73.5	79.9	
152	203	270	353	408	446	
235	313	418	553	642	710	
366	488	653	860	1000	1100	
540	723	965	1265	1465	1610	
955	1270	1700	2250	2615	2900	
1640	2180	2920	3870	4500	4990	
2696	3590	4809	6368	7422	8209	

**Evaporating temperature -60°F**

ICM20-A33	0.2	9.4	12.6	16.5	21.1	24.1	26.2
ICM20-A	0.7	28.1	37.6	49.5	63.7	72.5	79
ICM20-B	2.8	147	199	266	347	400	440
ICM20-C	5.3	225	304	410	544	630	695
ICM25-A	7	352	475	640	845	980	1080
ICM32-A	10	520	703	943	1246	1440	1585
ICM40-A	17	910	1230	1660	2210	2570	2850
ICM50-A	27	1560	2110	2850	3800	4430	4900
ICM65-A	41	2567	3474	4699	6251	7292	8063

**Selection tables for expansion/liquid make-up applications**  
 Capacities for nominal conditions,  $Q_n$  (TR)

**R 744**

Type	Cv	Pressure drop across valve $\Delta p$ psi					
		15	30	60	120	180	240

Pressure drop across valve $\Delta p$ psi						
15	30	60	120	180	240	

**Evaporating temperature 60°F**

ICM20-A33	0.2	1.58	2.21	3.05	4.05	4.64	5
ICM20-A	0.7	4.8	6.7	9.2	12.3	14.2	15.3
ICM20-B	2.8	27.8	39	53.7	71.5	82	88.8
ICM20-C	5.3	46	64.5	89	118	136	146
ICM25-A	7	71.1	100	137	183	210	226
ICM32-A	10	102	144	198	264	303	327
ICM40-A	17	191	267	368	490	561	605
ICM50-A	27	332	465	640	855	976	1055
ICM65-A	41	543	762	1048	1393	1594	1713

**Evaporating temperature 40°F**

1.93	2.71	3.74	5.01	5.8	6.32	
5.8	8.2	11.3	15.2	17.6	19.2	
33.9	47.6	66	88.3	102	111	
56	79	109	146	169	184	
87	122	169	226	261	285	
125	176	242	325	376	410	
232	326	450	603	699	760	
405	570	785	1050	1215	1320	
664	933	1288	1720	1986	2159	

**Evaporating temperature 20°F**

ICM20-A33	0.2	2.27	3.16	4.35	5.82	6.75	7.38
ICM20-A	0.7	6.8	9.6	13.2	17.7	20.5	22.4
ICM20-B	2.8	39.9	55.7	76.5	102	118	130
ICM20-C	5.3	66	92	126	169	195	214
ICM25-A	7	102	142	196	261	303	330
ICM32-A	10	147	205	281	376	437	476
ICM40-A	17	273	381	524	699	805	880
ICM50-A	27	475	663	910	1215	1400	1535
ICM65-A	41	781	1088	1495	1990	2300	2510

**Evaporating temperature 0°F**

2.55	3.55	4.86	6.49	7.53	8.23	
7.7	10.7	14.7	19.7	22.8	25	
44.7	62.3	85.5	114	132	144	
74.3	103	141	188	217	237	
115	159	218	290	335	367	
165	230	315	418	485	528	
307	426	585	775	895	975	
535	745	1015	1350	1555	1700	
879	1221	1668	2210	2551	2783	

**Evaporating temperature -20°F**

ICM20-A33	0.2	2.78	3.87	5.3	7.05	8.15	8.9
ICM20-A	0.7	8.4	11.7	16	21.4	24.7	27
ICM20-B	2.8	48.9	68	93	123	142	155
ICM20-C	5.3	81	112	153	203	233	255
ICM25-A	7	125	174	237	313	362	395
ICM32-A	10	180	250	341	453	523	570
ICM40-A	17	335	464	633	835	960	1050
ICM50-A	27	584	810	1100	1450	1670	1820
ICM65-A	41	958	1332	1809	2383	2741	2987

**Evaporating temperature -40°F and**

3.02	4.17	5.68	7.52	8.64	9.41	
9.1	12.6	17.2	22.7	26.2	28.5	
53	73.3	99	131	150	164	
87.8	121	163	214	245	267	
135	187	253	331	380	414	
195	270	365	480	549	600	
362	500	675	878	1010	1100	
633	870	1170	1530	1750	1900	
1040	1431	1923	2510	2877	3129	

**Evaporating temperature -60°F**

ICM20-A33	0.2	3.19	4.41	5.97	7.84	8.99	9.76
ICM20-A	0.7	9.6	13.3	18.1	23.7	27.3	29.5
ICM20-B	2.8	56	77	104	136	156	169
ICM20-C	5.3	92.8	127	170	221	253	275
ICM25-A	7	143	197	263	342	391	425
ICM32-A	10	206	284	380	496	568	618
ICM40-A	17	383	524	700	907	1040	1130
ICM50-A	27	667	915	1215	1570	1800	1950
ICM65-A	41	1099	1499	1996	2587	2956	3211



**Selection tables for expansion/liquid make-up applications**
*Capacities for nominal conditions,  $Q_n$  (TR)*
**R 134a**

Type	Cv	Pressure drop across valve $\Delta p$ psi					
		15	30	60	120	180	240

Pressure drop across valve $\Delta p$ psi						
15	30	60	120	180	240	

**Evaporating temperature 60°F**

ICM20-A33	0.2	1.8	2.42	3.13	3.76	3.96	3.93
ICM20-A	0.7	5.5	7.3	9.5	11.4	12	11.9
ICM20-B	2.8	31.5	42	54.1	65	68.5	68.2
ICM20-C	5.3	52	69	88	105	111	111
ICM25-A	7	80.3	106	136	163	172	171
ICM32-A	10	116	154	198	237	250	249
ICM40-A	17	214	284	360	431	455	454
ICM50-A	27	373	493	625	745	787	787
ICM65-A	41	612	808	1026	1225	1292	1287

**Evaporating temperature 40°F**

1.88	2.51	3.21	3.82	3.99	3.93	
5.7	7.6	9.7	11.6	12.1	11.9	
32.7	43.5	55.3	65.8	68.8	68	
53.6	70.5	89	106	111	110	
83	109	138	164	172	170	
120	158	201	238	250	248	
222	289	364	432	455	452	
385	500	630	745	785	780	
631	823	1035	1226	1287	1278	

**Evaporating temperature 20°F**

ICM20-A33	0.2	1.95	2.58	3.26	3.82	3.93	3.87
ICM20-A	0.7	5.9	7.8	9.9	11.6	12	11.8
ICM20-B	2.8	33.6	44.3	55.5	65.5	68	66.7
ICM20-C	5.3	54.8	71	88.5	105	109	108
ICM25-A	7	85	110	138	162	169	167
ICM32-A	10	123	160	201	237	247	243
ICM40-A	17	225	291	363	428	447	442
ICM50-A	27	390	503	625	737	770	760
ICM65-A	41	640	824	1029	1211	1264	1249

**Evaporating temperature 0°F**

2	2.62	3.27	3.78	3.87	3.75	
6	7.9	9.9	11.4	11.7	11.4	
34.1	44.4	55.4	64.2	66.2	64.5	
54.8	70.2	87.5	102	106	104	
85	109	136	159	164	161	
124	160	199	232	240	235	
224	287	357	418	433	425	
387	495	615	720	747	735	
634	813	1010	1183	1227	1204	

**Evaporating temperature -20°F**

ICM20-A33	0.2	2.03	2.63	3.24	3.69	3.74	3.59
ICM20-A	0.7	6.1	7.9	9.8	11.2	11.3	10.9
ICM20-B	2.8	34	43.9	54.3	62.6	64	61.8
ICM20-C	5.3	53.5	68.5	85.3	99	102	99
ICM25-A	7	83.5	107	132	154	158	154
ICM32-A	10	122	157	195	225	231	224
ICM40-A	17	219	280	347	405	416	405
ICM50-A	27	377	480	597	695	720	710
ICM65-A	41	618	790	981	1144	1179	1148

**Evaporating temperature -40°F**

2.04	2.61	3.18	3.57	3.58	3.4	
6.1	7.8	9.6	10.8	10.8	10.3	
33.3	42.7	52.8	60.1	61	58.5	
51.7	66.6	82.5	95	97	93.7	
80.7	103.3	128	148	151	145	
119	153	189	217	220	212	
211	270	336	388	397	383	
362	463	575	667	685	660	
594	762	948	1098	1123	1082	

**Selection tables for expansion/liquid make-up applications**

Capacities for nominal conditions,  $Q_n$  (TR)

**R 404A**

Type	Cv	Pressure drop across valve $\Delta p$ psi					
		15	30	60	120	180	240

Pressure drop across valve $\Delta p$ psi						
15	30	60	120	180	240	

**Evaporating temperature 60°F**

ICM20-A33	0.2	1.44	1.95	2.54	3.07	3.18	3.06
ICM20-A	0.7	4.4	5.9	7.7	9.3	9.7	9.3
ICM20-B	2.8	25.2	34.1	44.5	53.5	55.5	53.8
ICM20-C	5.3	41.8	56.3	73	87.5	91	87.5
ICM25-A	7	64.5	87	113	135	141	136
ICM32-A	10	93	125	163	196	204	197
ICM40-A	17	173	233	300	360	373	360
ICM50-A	27	300	405	522	625	647	625
ICM65-A	41	494	664	856	1022	1059	1021

**Evaporating temperature 40°F**

1.55	2.09	2.71	3.25	3.38	3.26
4.7	6.3	8.2	9.9	10.2	9.9
27.2	36.5	47.3	56.5	58.8	57
45	60	77	92	95.5	92.5
69.5	93	119	143	148	144
100	134	173	207	215	208
186	248	318	377	393	381
325	431	550	655	680	660
532	707	904	1073	1113	1080

**Evaporating temperature 20°F**

ICM20-A33	0.2	1.64	2.2	2.84	3.37	3.48	3.36
ICM20-A	0.7	4.9	6.6	8.6	10.2	10.6	10.2
ICM20-B	2.8	28.7	38.4	49.1	58.2	60.5	58.5
ICM20-C	5.3	47.3	62.6	79.8	94.5	97.5	94.7
ICM25-A	7	73	97	123	146	151	147
ICM32-A	10	105	140	179	212	220	213
ICM40-A	17	195	259	327	387	402	389
ICM50-A	27	340	448	567	670	694	675
ICM65-A	41	558	736	931	1098	1137	1104

**Evaporating temperature 0°F**

1.72	2.28	2.92	3.43	3.51	3.38
5.2	6.9	8.8	10.4	10.6	10.3
29.9	39.5	50.3	59	60.6	58.5
49	64.3	81	95	98	94.5
76	99.5	125	147	152	147
109	144	183	214	221	214
202	264	332	389	401	389
352	457	573	672	694	672
577	751	940	1101	1135	1099

**Evaporating temperature -20°F**

ICM20-A33	0.2	1.78	2.35	2.96	3.42	3.48	3.32
ICM20-A	0.7	5.4	7.1	8.9	10.4	10.5	10.1
ICM20-B	2.8	30.8	40.2	50.5	58.7	60	57.5
ICM20-C	5.3	50	64.5	80.5	93.5	96	92.5
ICM25-A	7	77.5	100	125	145	149	143
ICM32-A	10	112	146	183	212	217	209
ICM40-A	17	205	265	330	383	394	380
ICM50-A	27	355	457	567	660	678	655
ICM65-A	41	584	751	933	1085	1113	1072

**Evaporating temperature -40°F**

1.82	2.38	2.95	3.37	3.39	3.2
5.5	7.2	8.9	10.2	10.3	9.7
31.2	40.2	50	57.5	58	55.3
50	63.6	79	91.5	93	89
77.5	99	123	142	144	138
113	144	180	207	211	201
204	259	323	373	380	363
353	447	555	643	657	630
571	734	913	1056	1076	1028

**Evaporating temperature -60°F**

ICM20-A33	0.2	1.86	2.38	2.91	3.27	3.25	3.04
ICM20-A	0.7	5.6	7.1	8.8	9.9	9.9	9.3
ICM20-B	2.8	31.1	39.5	48.8	55.6	55.6	52.2
ICM20-C	5.3	49	61.5	76.7	87.8	89	84
ICM25-A	7	76.3	96	119	137	138	130
ICM32-A	10	111	141	175	200	201	190
ICM40-A	17	200	250	312	360	363	343
ICM50-A	27	344	430	535	620	628	595
ICM65-A	41	564	708	881	1016	1027	972

**Motor valves, type ICM 20-150 and actuators type ICAD 600, 900 and 1200**

**Selection tables for expansion/liquid make-up applications**

Capacities for nominal conditions,  $Q_n$  (TR)

**R 22**

Type	Cv	Pressure drop across valve $\Delta p$ psi					
		15	30	60	120	180	240

Pressure drop across valve $\Delta p$ psi						
15	30	60	120	180	240	

**Evaporating temperature 60°F**

ICM20-A33	0.2	1.86	2.55	3.41	4.33	4.8	5.02
ICM20-A	0.7	5.6	7.7	10.3	13.1	14.5	15.2
ICM20-B	2.8	32.5	44.6	59.5	75.5	83.6	87.5
ICM20-C	5.3	54	73.5	97.5	123	136	142
ICM25-A	7	83.2	114	151	190	210	220
ICM32-A	10	120	164	218	275	305	320
ICM40-A	17	223	303	400	505	560	585
ICM50-A	27	388	528	695	878	970	1015
ICM65-A	41	638	868	1144	1439	1590	1665

**Evaporating temperature 40°F**

1.97	2.96	3.57	4.49	4.95	5.16	
6	8.2	10.8	13.6	15	15.6	
34.5	47	62	77.8	85.5	89.5	
57	77	101	126	139	145	
88	119	156	196	216	226	
127	172	226	283	313	327	
236	317	415	517	570	596	
410	550	720	895	990	1035	
674	906	1182	1475	1624	1698	

**Evaporating temperature 20°F**

ICM20-A33	0.2	2.07	2.8	3.68	4.6	5.03	5.23
ICM20-A	0.7	6.3	8.5	11.2	13.9	15.2	15.9
ICM20-B	2.8	36	48.7	63.6	79	87	90.6
ICM20-C	5.3	59.5	79.5	103	128	140	146
ICM25-A	7	92	123	160	198	218	227
ICM32-A	10	133	178	232	289	317	329
ICM40-A	17	245	326	423	525	575	600
ICM50-A	27	427	565	730	905	995	1038
ICM65-A	41	700	930	1201	1489	1637	1709

**Evaporating temperature 0°F**

2.14	2.89	3.76	4.65	5.06	5.24	
6.5	8.7	11.4	14.1	15.3	15.9	
37.3	49.8	64.5	80	87	90.2	
60.7	80.5	104	128	140	146	
94	125	161	199	217	226	
136	181	234	289	316	329	
250	330	424	524	575	599	
435	570	730	905	993	1035	
714	938	1203	1487	1630	1698	

**Evaporating temperature -20°F**

ICM20-A33	0.2	2.21	2.95	3.8	4.65	5.05	5.19
ICM20-A	0.7	6.7	8.9	11.5	14.1	15.2	15.7
ICM20-B	2.8	37.9	50.3	64.5	79.2	86.2	89.1
ICM20-C	5.3	61.3	80.1	103	127	138	144
ICM25-A	7	95	125	160	197	215	223
ICM32-A	10	138	182	233	287	314	325
ICM40-A	17	251	329	421	518	567	590
ICM50-A	27	435	565	725	895	980	1020
ICM65-A	41	714	932	1192	1470	1608	1672

**Evaporating temperature -40°F**

2.25	2.98	3.81	4.61	4.97	5.1	
6.8	9	11.5	13.9	15	15.4	
38.1	50.2	64	78.5	85	87.6	
60.5	79	101	125	136	140	
94	123	157	193	211	218	
138	180	231	283	307	318	
248	323	413	510	555	575	
428	555	710	875	960	995	
702	913	1170	1443	1575	1634	

**Evaporating temperature -60°F**

ICM20-A33	0.2	2.27	2.98	3.78	4.53	4.86	4.96
ICM20-A	0.7	6.9	9	11.4	13.7	14.7	15
ICM20-B	2.8	37.7	49.5	63	76.8	83	85
ICM20-C	5.3	59	77	99	122	132	136
ICM25-A	7	92	120	154	189	205	212
ICM32-A	10	135	177	227	276	300	309
ICM40-A	17	240	314	403	498	540	560
ICM50-A	27	412	540	695	855	935	965
ICM65-A	41	679	888	1143	1408	1534	1586

Nominal capacities

## Selection tables for solenoid function and pressure regulator function in the liquid line with/without phase change

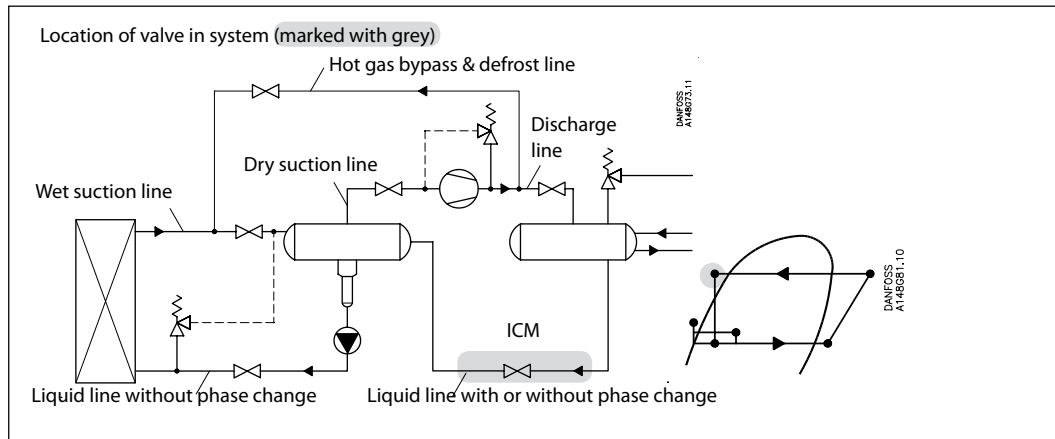

Calculation example (R717 capacities):

An application has following running conditions:

$T_e = -20^\circ\text{F}$   
 $Q_o = 130 \text{ TR}$   
 $T_{liq} = 50^\circ\text{F}$   
 Max.  $\Delta p = 3.5 \text{ psi}$   
 Connection:  $3/4"$

The capacity table is based on nominal condition (pressure drop  $\Delta p = 3 \text{ psi}$ ,  $T_{liq} = 90^\circ\text{F}$ )

Therefore the actual capacity must be corrected to nominal condition by means of correction factors.

Correction factor for  $\Delta p$  3.5 psi  $f_{\Delta p} = 0.91$

Correction factor for liquid temperature

$f_{T_{liq}} = 0.92$

$$Q_n = Q_o \times f_{\Delta p} \times f_{T_{liq}} = 130 \times 0.91 \times 0.92 = 109 \text{ TR}$$

From the capacity table a ICM 20-C with  $Q_n$  capacity 134 TR is selected.

Nominal capacities

## Selection tables for solenoid function and pressure regulator function in the liquid line with/without phase change

Capacity table for nominal conditions,  $Q_N$  [Tons of Refrigeration],  
 $T_{liq} = 90^\circ\text{F}$ ,  
 $\Delta P = 3$  psi

### R 717

Type	Valve body size	$C_v$ (USgal/min)	Evaporating temperature [°F]							
			-60	-40	-20	0	20	40	60	80
ICM20-A33	20	0.23	5.6	5.7	5.8	5.9	6.0	6.0	6.1	6.1
ICM20-A		0.7	17.1	17.4	17.7	17.9	18.1	18.3	18.4	18.5
ICM20-B		2.8	68.3	69.5	70.7	71.7	72.5	73.2	73.7	74.0
ICM20-C		5.3	129	132	134	136	137	139	140	140
ICM25-A	25	7	171	174	177	179	181	183	184	185
ICM25-B		14	342	348	353	358	363	366	369	370
ICM32-A	32	10	244	248	252	256	259	261	263	264
ICM32-B		20	488	497	505	512	518	523	527	529
ICM40-A	40	17	415	422	429	435	440	445	448	450
ICM40-B		30	732	745	757	768	777	784	790	793
ICM50-A	50	27	659	670	681	691	699	706	711	714
ICM50-B		46	1122	1142	1161	1177	1191	1203	1211	1216
ICM65-A	65	41	1000	1018	1035	1049	1061	1072	1080	1084
ICM65-B		81	1976	2011	2044	2073	2098	2118	2133	2142
ICM100	100	165	4026	4099	4165	4223	4271	4315	4345	4362
ICM125	125	259	6320	6433	6538	6629	6705	6773	6820	6846
ICM150	150	430	10493	10681	10855	11006	11132	11245	11323	11367

#### Correction factor for $\Delta P$ ( $f_{\Delta P}$ )

$\Delta P$ (psi)	Correction factor
0.75	1.97
1.5	1.39
<b>3</b>	<b>1.00</b>
3.5	0.91
4	0.85
4.5	0.81

#### Correction factor for liquid temperature ( $T_{liq}$ )

Liquid temperature	Correction factor
-10°F	0.82
10°F	0.85
30°F	0.88
50°F	0.92
70°F	0.96
<b>90°F</b>	<b>1.00</b>
110°F	1.04
130°F	1.09

Capacity table for nominal conditions,  $Q_N$  [Tons of Refrigeration],  
 $T_{liq} = 50^\circ\text{F}$ ,  
 $\Delta P = 3$  psi

### R 744

Type	Valve body size	$C_v$ (USgal/min)	Evaporating temperature [°F]							
			-60	-40	-20	0	20	40	60	
ICM20-A33	20	0.23	1.4	1.4	1.4	1.4	1.4	1.4	1.4	1.3
ICM20-A		0.7	4.2	4.2	4.3	4.3	4.2	4.1	3.9	
ICM20-B		2.8	16.7	17.0	17.1	17.1	16.9	16.5	15.5	
ICM20-C		5.3	31.7	32.2	32.5	32.5	32.1	31.1	29.3	
ICM25-A	25	7	41.8	42.5	42.9	42.9	42.3	41.1	38.7	
ICM25-B		14	83.7	85.0	85.7	85.7	84.7	82.3	77.3	
ICM32-A	32	10	59.8	60.7	61.2	61.2	60.5	58.8	55.2	
ICM32-B		20	120	121	122	122	121	118	110	
ICM40-A	40	17	102	103	104	104	103	100	94	
ICM40-B		30	179	182	184	184	181	176	166	
ICM50-A	50	27	161	164	165	165	163	159	149	
ICM50-B		46	275	279	282	282	278	270	254	
ICM65-A	65	41	245	249	251	251	248	241	227	
ICM65-B		81	484	492	496	496	490	476	448	
ICM100	100	165	987	1000	1010	1010	997	970	912	
ICM125	125	259	1549	1570	1586	1586	1565	1522	1432	
ICM150	150	430	2571	2607	2633	2633	2598	2527	2377	

#### Correction factor for $\Delta P$ ( $f_{\Delta P}$ )

$\Delta P$ (psi)	Correction factor
0.75	1.97
1.5	1.39
<b>3</b>	<b>1.00</b>
3.5	0.91
4	0.85
4.5	0.81

#### Correction factor for liquid temperature ( $T_{liq}$ )

Liquid temperature	Correction factor
-10°F	0.48
10°F	0.64
30°F	0.88
<b>50°F</b>	<b>1.00</b>

Nominal capacities

## Selection tables for solenoid function and pressure regulator function in the liquid line with/without phase change

### R 134a

Capacity table for nominal conditions,  $Q_N$  [Tons of Refrigeration],  
 $T_{liq} = 90^\circ\text{F}$ ,  
 $\Delta P = 3 \text{ psi}$

Type	Valve body size	$C_v$ (USgal/min)	Evaporating temperature [°F]						
			-40	-20	0	20	40	60	80
ICM20-A33	20	0.23	1.0	1.0	1.1	1.2	1.2	1.2	1.3
ICM20-A		0.7	3.0	3.2	3.3	3.5	3.7	3.8	3.9
ICM20-B		2.8	12.1	12.7	13.4	14.0	14.6	15.2	15.8
ICM20-C		5.3	22.9	24.1	25.3	26.5	27.7	28.8	29.8
ICM25-A	25	7	30.2	31.8	33.4	35.0	36.6	38.0	39.4
ICM25-B		14	60.4	63.7	66.9	70.1	73.1	76.0	78.8
ICM32-A	32	10	43.1	45.5	47.8	50.1	52.2	54.3	56.3
ICM32-B		20	86.3	91.0	95.6	100	104	109	113
ICM40-A	40	17	73.4	77.3	81.2	85.1	88.8	92.3	95.7
ICM40-B		30	129	136	143	150	157	163	169
ICM50-A	50	27	117	123	129	135	141	147	152
ICM50-B		46	198	209	220	230	240	250	259
ICM65-A	65	41	177	186	196	205	214	223	231
ICM65-B		81	350	369	387	406	423	440	456
ICM100	100	165	712	751	787	825	862	897	928
ICM125	125	259	1117	1178	1236	1296	1354	1407	1457
ICM150	150	430	1855	1956	2052	2151	2247	2336	2420

Correction factor for  $\Delta P$  ( $f_{\Delta P}$ )

$\Delta P$ (psi)	Correction factor
0.75	1.97
1.5	1.39
<b>3</b>	<b>1.00</b>
3.5	0.91
4	0.85
4.5	0.81

Correction factor for liquid temperature ( $T_{liq}$ )

Liquid temperature	Correction factor
-10°F	0.64
10°F	0.68
30°F	0.74
50°F	0.81
70°F	0.89
<b>90°F</b>	<b>1.00</b>
110°F	1.15
130°F	1.35

Capacity table for nominal conditions,  $Q_N$  [Tons of Refrigeration],  
 $T_{liq} = 90^\circ\text{F}$ ,  
 $\Delta P = 3 \text{ psi}$

### R 404A

Type	Valve body size	$C_v$ (USgal/min)	Evaporating temperature [°F]							
			-60	-40	-20	0	20	40	60	80
ICM20-A33	20	0.23	0.6	0.7	0.7	0.8	0.8	0.9	0.9	0.9
ICM20-A		0.7	1.9	2.1	2.2	2.4	2.5	2.6	2.8	2.9
ICM20-B		2.8	7.6	8.2	8.8	9.5	10.0	10.6	11.0	11.4
ICM20-C		5.3	14.4	15.6	16.8	17.9	19.0	20.0	20.9	21.7
ICM25-A	25	7	19.0	20.6	22.1	23.6	25.1	26.4	27.6	28.6
ICM25-B		14	38.0	41.1	44.2	47.3	50.1	52.8	55.2	57.2
ICM32-A	32	10	27.2	29.4	31.6	33.8	35.8	37.7	39.4	40.9
ICM32-B		20	54.3	58.8	63.2	67.5	71.6	75.5	78.9	81.7
ICM40-A	40	17	46.2	50.0	53.7	57.4	60.9	64.1	67.1	69.5
ICM40-B		30	81.5	88.1	94.8	101	107	113	118	123
ICM50-A	50	27	73.3	79.3	85.3	91.2	96.7	102	107	110
ICM50-B		46	125	135	145	155	165	174	181	188
ICM65-A	65	41	111	121	129	139	147	155	162	168
ICM65-B		81	220	238	256	274	290	306	320	331
ICM100	100	165	448	486	521	558	591	622	651	675
ICM125	125	259	703	762	818	876	927	976	1022	1060
ICM150	150	430	1168	1266	1357	1454	1539	1621	1697	1759

Correction factor for  $\Delta P$  ( $f_{\Delta P}$ )

$\Delta P$ (psi)	Correction factor
0.75	1.97
1.5	1.39
<b>3</b>	<b>1.00</b>
3.5	0.91
4	0.85
4.5	0.81

Correction factor for liquid temperature ( $T_{liq}$ )

Liquid temperature	Correction factor
-10°F	0.52
10°F	0.57
30°F	0.63
50°F	0.72
70°F	0.83
<b>90°F</b>	<b>1.00</b>
110°F	1.29
130°F	1.92

## Selection tables for solenoid function and pressure regulator function in the liquid line with/without phase change

### Nominal capacities

Capacity table for nominal conditions,  $Q_N$  [Tons of Refrigeration],  
 $T_{liq} = 90^\circ\text{F}$ ,  
 $\Delta P = 3 \text{ psi}$

### R 22

Type	Valve body size	$C_v$ (USgal/min)	Evaporating temperature [°F]							
			-60	-40	-20	0	20	40	60	80
ICM20-A33	20	0.23	1.1	1.1	1.2	1.2	1.3	1.3	1.3	1.3
ICM20-A		0.7	3.4	3.5	3.6	3.7	3.8	3.9	4.0	4.1
ICM20-B		2.8	13.5	14.0	14.4	14.9	15.3	15.7	16.0	16.3
ICM20-C		5.3	25.5	26.4	27.4	28.2	29.0	29.7	30.4	30.9
ICM25-A	25	7	33.7	34.9	36.1	37.2	38.3	39.2	40.1	40.8
ICM25-B		14	67.4	69.8	72.2	74.5	76.6	78.5	80.2	81.6
ICM32-A	32	10	48.1	49.9	51.6	53.2	54.7	56.0	57.3	58.3
ICM32-B		20	96.3	100	103	106	109	112	115	117
ICM40-A	40	17	81.9	84.8	87.7	90.5	93.0	95.3	97.4	99.1
ICM40-B		30	144	150	155	160	164	168	172	175
ICM50-A	50	27	130	135	139	144	148	151	155	157
ICM50-B		46	221	229	237	245	252	258	264	268
ICM65-A	65	41	197	205	211	218	224	230	235	239
ICM65-B		81	390	404	418	431	443	454	464	472
ICM100	100	165	795	824	851	878	902	924	946	962
ICM125	125	259	1247	1293	1335	1377	1416	1450	1484	1510
ICM150	150	430	2071	2146	2217	2287	2350	2408	2464	2507

### Correction factor for $\Delta P$ ( $f_{\Delta P}$ )

$\Delta P$ (psi)	Correction factor
<b>3</b>	<b>1.00</b>
4	0.87
5	0.79
6	0.72
7	0.66
8	0.62

### Correction factor for liquid temperature ( $T_{liq}$ )

Liquid temperature	Correction factor
-10°F	0.73
10°F	0.77
30°F	0.82
50°F	0.87
70°F	0.93
<b>90°F</b>	<b>1.00</b>
110°F	1.09
130°F	1.20

Nominal capacities

## Selection tables for solenoid or pressure regulator function in pumped liquid line without phase change

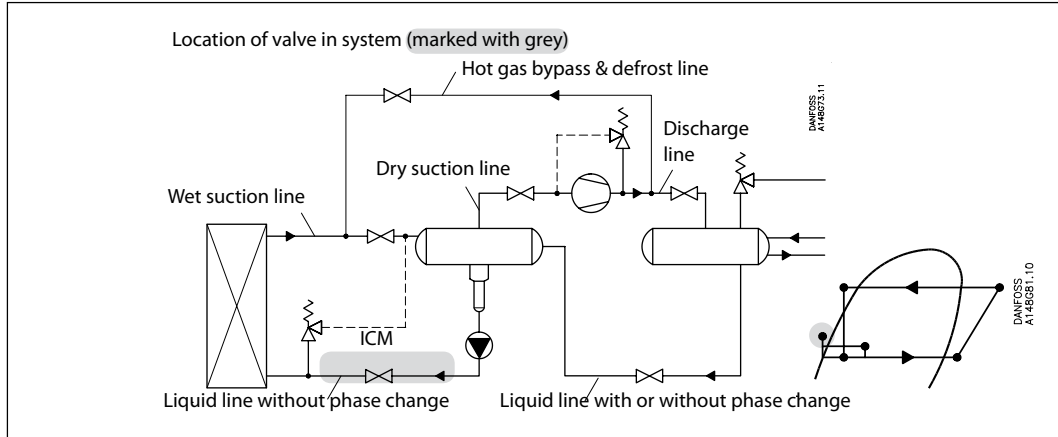

*Calculation example (R717 capacities):*

An application has following running conditions:

$T_e = -20^\circ\text{F}$   
 $Q_o = 130 \text{ TR}$   
 Circulation rate = 3  
 Max.  $\Delta p = 3.5 \text{ psi}$   
 Connection:  $1\frac{1}{4}''$

The capacity table is based on nominal condition (pressure drop  $\Delta p = 3 \text{ psi}$ , circulation rate = 4)

Therefore the actual capacity must be corrected to nominal condition by means of correction factors.

Correction factor for  $\Delta p \text{ } 3.5 \text{ psi } f_{\Delta p} = 0.91$   
 Correction factor for circulation rate  $f_{rec} = 0.75$

$$Q_n = Q_o \times f_{\Delta p} \times f_{rec} = 130 \times 0.91 \times 0.75 = 89 \text{ TR}$$

From the capacity table a ICM 32-B with  $Q_n$  capacity 171 TR is selected.



Nominal capacities

Capacity table at nominal conditions,  
 $Q_N$  [Tons of Refrigeration],  
 Circulation rate = 4,  
 $\Delta p = 3$  psi

## Selection tables for solenoid or pressure regulator function in pumped liquid line without phase change

### R 717

Type	Valve body size	$C_v$ (USgal/min)	Evaporating temperature [°F]							
			-60	-40	-20	0	20	40	60	80
ICM20-A33	20	0.23	2.1	2.0	2.0	1.9	1.8	1.7	1.7	1.6
ICM20-A		0.7	6.4	6.2	6.0	5.8	5.5	5.3	5.0	4.8
ICM20-B		2.8	25.6	24.8	24.0	23.1	22.2	21.2	20.2	19.1
ICM20-C		5.3	48.4	46.9	45.3	43.7	41.9	40.1	38.1	36.1
ICM25-A	25	7	64.0	62.0	59.9	57.7	55.4	53.0	50.4	47.7
ICM25-B		14	128	124	120	115	111	106	101	95.4
ICM32-A	32	10	91.4	88.5	85.6	82.5	79.1	75.7	72.0	68.1
ICM32-B		20	183	177	171	165	158	151	144	136
ICM40-A	40	17	155	150	145	140	135	129	122	116
ICM40-B		30	274	266	257	247	237	227	216	204
ICM50-A	50	27	247	239	231	223	214	204	194	184
ICM50-B		46	420	407	394	379	364	348	331	313
ICM65-A	65	41	375	363	351	338	324	310	295	279
ICM65-B		81	740	717	693	668	641	613	583	552
ICM100	100	165	1508	1461	1412	1361	1305	1249	1187	1125
ICM125	125	259	2367	2293	2217	2136	2049	1960	1863	1765
ICM150	150	430	3929	3806	3680	3546	3402	3254	3093	2931

Correction factor for  $\Delta P$  ( $f_{\Delta P}$ )

$\Delta P$ (psi)	Correction factor
0.75	1.97
1.5	1.39
<b>3</b>	<b>1.00</b>
3.5	0.91
4	0.85
4.5	0.81

Correction factor for circulation rate ( $f_{rec}$ )

Circulation rate	Correction factor
2	0.5
3	0.75
<b>4</b>	<b>1</b>
6	1.5
8	2
10	2.5

Capacity table at nominal conditions,  
 $Q_N$  [Tons of Refrigeration],  
 Circulation rate = 4,  
 $\Delta p = 3$  psi

### R 744

Type	Valve body size	$C_v$ (USgal/min)	Evaporating temperature [°F]							
			-60	-40	-20	0	20	40	60	
ICM20-A33	20	0.23	0.7	0.6	0.6	0.5	0.4	0.4	0.3	
ICM20-A		0.7	2.0	1.8	1.7	1.5	1.3	1.1	0.9	
ICM20-B		2.8	7.9	7.4	6.8	6.1	5.4	4.5	3.4	
ICM20-C		5.3	15.0	13.9	12.8	11.6	10.1	8.5	6.5	
ICM25-A	25	7	19.8	18.4	16.9	15.3	13.4	11.2	8.6	
ICM25-B		14	39.5	36.8	33.9	30.5	26.8	22.5	17.2	
ICM32-A	32	10	28.2	26.3	24.2	21.8	19.1	16.1	12.3	
ICM32-B		20	56.4	52.6	48.4	43.6	38.3	32.1	24.6	
ICM40-A	40	17	48.0	44.7	41.1	37.1	32.5	27.3	20.9	
ICM40-B		30	84.7	78.9	72.6	65.4	57.4	48.2	37.0	
ICM50-A	50	27	76.2	71.0	65.3	58.9	51.7	43.4	33.3	
ICM50-B		46	130	121	111	100	88.0	73.9	56.7	
ICM65-A	65	41	116	108	99	89	78	66	51	
ICM65-B		81	229	213	196	177	155	130	100	
ICM100	100	165	466	433	399	359	315	264	204	
ICM125	125	259	732	680	627	564	495	415	320	
ICM150	150	430	1216	1129	1040	937	821	689	531	

Correction factor for  $\Delta P$  ( $f_{\Delta P}$ )

$\Delta P$ (psi)	Correction factor
0.75	1.97
1.5	1.39
<b>3</b>	<b>1.00</b>
3.5	0.91
4	0.85
4.5	0.81

Correction factor for circulation rate ( $f_{rec}$ )

Circulation rate	Correction factor
2	0.5
3	0.75
<b>4</b>	<b>1</b>
6	1.5
8	2
10	2.5

Nominal capacities

## Selection tables for solenoid or pressure regulator function in pumped liquid line without phase change

Capacity table at nominal conditions,  $Q_N$  [Tons of Refrigeration], Circulation rate = 4,  $\Delta p = 3$  psi

### R 134a

Type	Valve body size	$C_v$ (USgal/min)	Evaporating temperature [°F]						
			-40	-20	-0	20	40	60	80
ICM20-A33	20	0.23	0.5	0.5	0.4	0.4	0.4	0.4	0.3
ICM20-A		0.7	1.4	1.4	1.3	1.3	1.2	1.1	1.0
ICM20-B		2.8	5.8	5.5	5.3	5.0	4.8	4.5	4.2
ICM20-C		5.3	10.9	10.5	10.0	9.5	9.0	8.5	7.9
ICM25-A	25	7	14.4	13.8	13.2	12.6	11.9	11.2	10.4
ICM25-B		14	28.8	27.7	26.4	25.1	23.8	22.4	20.8
ICM32-A	32	10	20.6	19.8	18.9	18.0	17.0	16.0	14.9
ICM32-B		20	41.1	39.5	37.8	35.9	34.0	32.0	29.8
ICM40-A	40	17	35.0	33.6	32.1	30.5	28.9	27.2	25.3
ICM40-B		30	61.7	59.3	56.7	53.9	51.0	48.0	44.6
ICM50-A	50	27	55.5	53.3	51.0	48.5	45.9	43.2	40.2
ICM50-B		46	94.6	90.9	86.9	82.6	78.2	73.5	68.4
ICM65-A	65	41	84	81	77	74	70	66	61
ICM65-B		81	167	160	153	146	138	130	121
ICM100	100	165	339	326	311	297	281	264	245
ICM125	125	259	532	512	489	466	441	414	385
ICM150	150	430	883	850	811	774	732	687	638

Correction factor for  $\Delta P$  ( $f_{\Delta P}$ )

$\Delta P$ (psi)	Correction factor
3	1.00
4	0.87
5	0.79
6	0.72
7	0.66
8	0.62

Correction factor for circulation rate ( $f_{rec}$ )

Circulation rate	Correction factor
2	0.5
3	0.75
4	1
6	1.5
8	2
10	2.5

Capacity table at nominal conditions,  $Q_N$  [Tons of Refrigeration], Circulation rate = 4,  $\Delta p = 3$  psi

### R 404A

Type	Valve body size	$C_v$ (USgal/min)	Evaporating temperature [°F]							
			-60	-40	-20	0	20	40	60	80
ICM20-A33	20	0.23	0.4	0.4	0.4	0.4	0.3	0.3	0.3	0.3
ICM20-A		0.7	1.3	1.2	1.1	1.1	1.0	1.0	0.9	0.8
ICM20-B		2.8	5.1	4.9	4.6	4.4	4.1	3.8	3.5	3.1
ICM20-C		5.3	9.7	9.2	8.7	8.2	7.7	7.2	6.6	5.9
ICM25-A	25	7	12.7	12.2	11.5	10.9	10.2	9.5	8.7	7.8
ICM25-B		14	25.5	24.4	23.0	21.8	20.4	19.0	17.4	15.5
ICM32-A	32	10	18.2	17.4	16.4	15.6	14.6	13.6	12.4	11.1
ICM32-B		20	36.4	34.8	32.8	31.1	29.2	27.2	24.8	22.2
ICM40-A	40	17	31.0	29.6	27.9	26.4	24.8	23.1	21.1	18.8
ICM40-B		30	54.6	52.2	49.3	46.7	43.8	40.7	37.2	33.3
ICM50-A	50	27	49.2	47.0	44.3	42.0	39.4	36.7	33.5	29.9
ICM50-B		46	83.8	80.1	75.5	71.6	67.2	62.5	57.1	51.0
ICM65-A	65	41	75	71	67	64	60	56	51	46
ICM65-B		81	148	141	133	126	118	110	101	89.8
ICM100	100	165	301	287	270	257	240	225	206	183
ICM125	125	259	473	450	424	404	377	353	323	288
ICM150	150	430	785	748	703	670	626	587	536	478

Correction factor for  $\Delta P$  ( $f_{\Delta P}$ )

$\Delta P$ (psi)	Correction factor
0.75	1.97
1.5	1.39
3	1.00
3.5	0.91
4	0.85
4.5	0.81

Correction factor for circulation rate ( $f_{rec}$ )

Circulation rate	Correction factor
2	0.5
3	0.75
4	1
6	1.5
8	2
10	2.5

**Nominal capacities**

Capacity table at nominal conditions,  
 $Q_N$  [Tons of Refrigeration],  
 Circulation rate = 4,  
 $\Delta p = 3$  psi

## Selection tables for solenoid or pressure regulator function in pumped liquid line without phase change

### R 22

Type	Valve body size	$C_v$ (USgal/min)	Evaporating temperature [°F]							
			-60	-40	-20	0	20	40	60	80
ICM20-A33	20	0.23	0.5	0.5	0.5	0.5	0.4	0.4	0.4	0.4
ICM20-A		0.7	1.6	1.5	1.4	1.4	1.3	1.2	1.2	1.1
ICM20-B		2.8	6.2	6.0	5.8	5.5	5.2	4.9	4.6	4.3
ICM20-C		5.3	11.8	11.4	10.9	10.4	9.9	9.3	8.7	8.1
ICM25-A	25	7	15.6	15.0	14.4	13.7	13.1	12.3	11.6	10.7
ICM25-B		14	31.2	30.1	28.8	27.5	26.1	24.7	23.1	21.4
ICM32-A	32	10	22.3	21.5	20.6	19.6	18.7	17.6	16.5	15.3
ICM32-B		20	44.6	43.0	41.2	39.3	37.3	35.2	33.0	30.6
ICM40-A	40	17	37.9	36.5	35.0	33.4	31.7	29.9	28.1	26.0
ICM40-B		30	66.9	64.4	61.7	58.9	56.0	52.9	49.5	45.9
ICM50-A	50	27	60.2	58.0	55.6	53.0	50.4	47.6	44.6	41.3
ICM50-B		46	103	98.8	94.7	90.4	85.8	81.0	75.9	70.4
ICM65-A	65	41	92	88	84	81	76	72	68	63
ICM65-B		81	181	174	167	159	151	143	134	124
ICM100	100	165	369	354	339	324	308	290	273	253
ICM125	125	259	579	556	532	509	483	455	429	397
ICM150	150	430	961	923	884	845	802	755	712	659

**Correction factor for  $\Delta P$  ( $f_{\Delta P}$ )**

$\Delta P$ (psi)	Correction factor
<b>3</b>	<b>1.00</b>
4	0.87
5	0.79
6	0.72
7	0.66
8	0.62

**Correction factor for  
 circulation rate ( $f_{rec}$ )**

Circulation rate	Correction factor
2	0.5
3	0.75
<b>4</b>	<b>1</b>
6	1.5
8	2
10	2.5

## Selection tables for solenoid or pressure regulator function in wet suction line

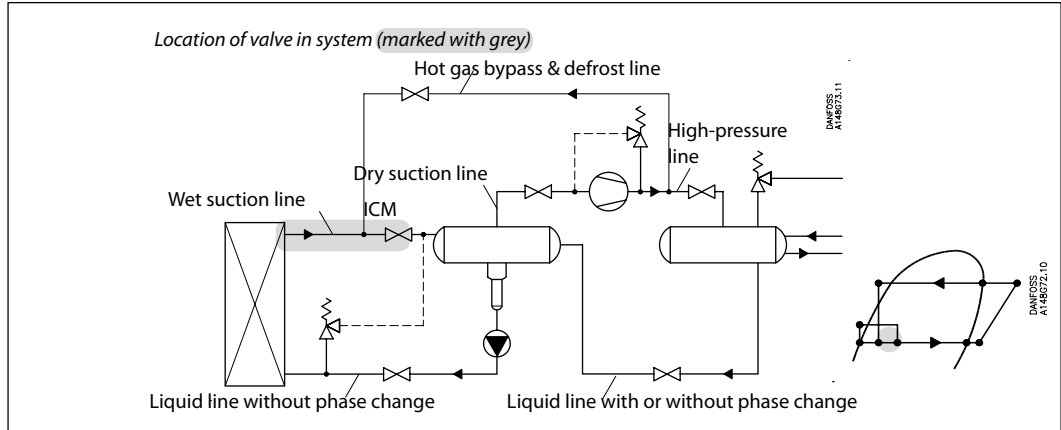

### Calculation example (R717 capacities):

An application has following running conditions:

$T_e = -20\text{ F}$   
 $Q_o = 8\text{ TR}$   
 Circulation rate = 3  
 Max.  $\Delta p = 3.5\text{ psi}$   
 Connection: 1"

The capacity table is based on nominal condition (pressure drop  $\Delta p = 3\text{ psi}$ , recirculation rate = 4)

Therefore the actual capacity must be corrected to nominal condition by means of correction factors.

Correction factor for  $\Delta p\ 3.5\text{ psi}$   $f_{\Delta p} = 0.91$   
 Correction factor for circulation rate  $f_{rec} = 0.9$

$$Q_n = Q_o \times f_{\Delta p} \times f_{rec} = 8 \times 0.91 \times 0.9 = 6.6\text{ TR}$$

From the capacity table a ICM 25-B with  $Q_n$  capacity 10.2 TR is selected.

Nominal capacities

## Selection tables for solenoid or pressure regulator function in wet suction line

Capacity table at nominal conditions, **R 717**

$Q_N$  [Tons of Refrigeration],

Circulation rate = 4,

$\Delta p = 3$  psi

Type	Valve body size	$C_v$ (USgal/min)	Evaporating temperature [°F]							
			-60	-40	-20	0	20	40	60	80
ICM20-A33	20	0.23	0.08	0.12	0.17	0.21	0.26	0.30	0.35	0.40
ICM20-A		0.7	0.2	0.4	0.5	0.6	0.8	0.9	1.1	1.2
ICM20-B		2.8	0.9	1.5	2.0	2.6	3.1	3.7	4.3	4.9
ICM20-C		5.3	1.8	2.8	3.9	4.9	5.9	7.0	8.1	9.3
ICM25-A	25	7	2.3	3.8	5.1	6.4	7.8	9.3	10.8	12.3
ICM25-B		14	4.6	7.5	10.2	12.9	15.7	18.5	21.5	24.5
ICM32-A	32	10	3.3	5.4	7.3	9.2	11.2	13.2	15.4	17.5
ICM32-B		20	6.6	10.7	14.6	18.4	22.4	26.5	30.7	35.0
ICM40-A	40	17	5.6	9.1	12.4	15.6	19.0	22.5	26.1	29.8
ICM40-B		30	9.9	16.1	21.9	27.6	33.5	39.7	46.1	52.5
ICM50-A	50	27	8.9	14.5	19.7	24.8	30.2	35.8	41.5	47.3
ICM50-B		46	15.2	24.7	33.5	42.3	51.4	60.9	70.7	80.5
ICM65-A	65	41	13	22	30	38	46	54	63	72
ICM65-B		81	26.8	43.5	59.0	74.5	90.6	107	125	142
ICM100	100	165	54	89	120	151	185	218	254	289
ICM125	125	259	84	140	188	237	290	342	399	453
ICM150	150	430	140	232	313	394	481	568	662	752

Correction factor for  $\Delta P$  ( $f_{\Delta P}$ )

$\Delta P$ (psi)	Correction factor
0.75	1.97
1.5	1.39
<b>3</b>	<b>1.00</b>
3.5	0.91
4	0.85
4.5	0.81

Correction factor for circulation rate ( $f_{rec}$ )

Circulation rate	Correction factor
2	0.77
3	0.90
<b>4</b>	<b>1</b>
6	1.13
8	1.20
10	1.25

Capacity table at nominal conditions, **R 744**

$Q_N$  [Tons of Refrigeration],

Circulation rate = 4,

$\Delta p = 3$  psi

Type	Valve body size	$C_v$ (USgal/min)	Evaporating temperature [°F]							
			-60	-40	-20	0	20	40	60	
ICM20-A33	20	0.23	0.17	0.20	0.23	0.25	0.27	0.28	0.27	
ICM20-A		0.7	0.5	0.6	0.7	0.8	0.8	0.9	0.8	
ICM20-B		2.8	2.1	2.4	2.8	3.1	3.3	3.4	3.3	
ICM20-C		5.3	4.0	4.6	5.3	5.8	6.3	6.5	6.3	
ICM25-A	25	7	5.2	6.1	7.0	7.7	8.3	8.6	8.4	
ICM25-B		14	10.5	12.2	13.9	15.4	16.6	17.2	16.7	
ICM32-A	32	10	7.5	8.7	9.9	11.0	11.9	12.3	11.9	
ICM32-B		20	14.9	17.4	19.9	22.0	23.7	24.6	23.9	
ICM40-A	40	17	12.7	14.8	16.9	18.7	20.1	20.9	20.3	
ICM40-B		30	22.4	26.1	29.8	33.0	35.6	36.9	35.8	
ICM50-A	50	27	20.2	23.5	26.8	29.7	32.0	33.2	32.2	
ICM50-B		46	34.4	40.1	45.7	50.7	54.5	56.6	54.9	
ICM65-A	65	41	31	36	41	45	48	51	49	
ICM65-B		81	60.5	70.6	80.5	89.2	96.0	100	97	
ICM100	100	165	123	143	164	182	195	203	196	
ICM125	125	259	193	225	258	286	306	319	308	
ICM150	150	430	320	373	428	475	508	530	511	

Correction factor for  $\Delta P$  ( $f_{\Delta P}$ )

$\Delta P$ (psi)	Correction factor
0.75	1.97
1.5	1.39
<b>3</b>	<b>1.00</b>
3.5	0.91
4	0.85
4.5	0.81

Correction factor for circulation rate ( $f_{rec}$ )

Circulation rate	Correction factor
2	0.77
3	0.90
<b>4</b>	<b>1</b>
6	1.13
8	1.20
10	1.25

Nominal capacities

## Selection tables for solenoid or pressure regulator function in wet suction line

Capacity table at nominal conditions,  
 $Q_N$  [Tons of Refrigeration],  
 Circulation rate = 4,  
 $\Delta p = 3$  psi

### R 134a

Type	Valve body size	$C_v$ (USgal/min)	Evaporating temperature [°F]						
			-40	-20	0	20	40	60	80
ICM20-A33	20	0.23	0.04	0.05	0.07	0.08	0.10	0.11	0.13
ICM20-A		0.7	0.1	0.2	0.2	0.3	0.3	0.3	0.4
ICM20-B		2.8	0.5	0.7	0.8	1.0	1.2	1.4	1.5
ICM20-C		5.3	0.9	1.2	1.6	1.9	2.2	2.6	2.9
ICM25-A	25	7	1.2	1.6	2.1	2.5	2.9	3.4	3.8
ICM25-B		14	2.3	3.3	4.1	5.0	5.9	6.8	7.6
ICM32-A	32	10	1.7	2.3	3.0	3.6	4.2	4.8	5.4
ICM32-B		20	3.3	4.7	5.9	7.2	8.4	9.7	10.9
ICM40-A	40	17	2.8	4.0	5.0	6.1	7.2	8.2	9.2
ICM40-B		30	5.0	7.0	8.9	10.8	12.6	14.5	16.3
ICM50-A	50	27	4.5	6.3	8.0	9.7	11.4	13.0	14.7
ICM50-B		46	7.6	10.7	13.6	16.5	19.4	22.2	25.0
ICM65-A	65	41	7	10	12	15	17	20	22
ICM65-B		81	13.4	18.9	24.0	29.1	34.1	39.1	44.0
ICM100	100	165	27	39	49	60	70	79	90
ICM125	125	259	43	62	76	94	109	124	141
ICM150	150	430	71	102	127	157	181	207	234

Correction factor for  $\Delta P$  ( $f_{\Delta P}$ )

$\Delta P$ (psi)	Correction factor
<b>3</b>	<b>1.00</b>
4	0.87
5	0.79
6	0.72
7	0.66
8	0.62

Correction factor for circulation rate ( $f_{rec}$ )

Circulation rate	Correction factor
2	0.77
3	0.90
<b>4</b>	<b>1</b>
6	1.13
8	1.20
10	1.25

Capacity table at nominal conditions,  
 $Q_N$  [Tons of Refrigeration],  
 Circulation rate = 4,  
 $\Delta p = 3$  psi

### R 404A

Type	Valve body size	$C_v$ (USgal/min)	Evaporating temperature [°F]							
			-60	-40	-20	0	20	40	60	80
ICM20-A33	20	0.23	0.05	0.06	0.07	0.09	0.10	0.12	0.13	0.14
ICM20-A		0.7	0.1	0.2	0.2	0.3	0.3	0.4	0.4	0.4
ICM20-B		2.8	0.6	0.8	0.9	1.1	1.3	1.4	1.6	1.7
ICM20-C		5.3	1.1	1.4	1.7	2.1	2.4	2.7	3.0	3.2
ICM25-A	25	7	1.5	1.9	2.3	2.7	3.2	3.6	4.0	4.3
ICM25-B		14	2.9	3.8	4.6	5.5	6.3	7.2	7.9	8.6
ICM32-A	32	10	2.1	2.7	3.3	3.9	4.5	5.1	5.7	6.1
ICM32-B		20	4.2	5.4	6.6	7.8	9.1	10.2	11.3	12.2
ICM40-A	40	17	3.5	4.6	5.6	6.7	7.7	8.7	9.6	10.4
ICM40-B		30	6.2	8.1	9.9	11.7	13.6	15.4	17.0	18.3
ICM50-A	50	27	5.6	7.3	8.9	10.6	12.2	13.8	15.3	16.5
ICM50-B		46	9.6	12.4	15.2	18.0	20.8	23.6	26.1	28.1
ICM65-A	65	41	8	11	13	16	19	21	23	25
ICM65-B		81	16.9	21.9	26.7	31.7	36.7	41.5	45.9	49.5
ICM100	100	165	34	45	54	65	75	85	94	100
ICM125	125	259	53	71	84	102	117	134	147	157
ICM150	150	430	88	117	140	170	194	222	244	261

Correction factor for  $\Delta P$  ( $f_{\Delta P}$ )

$\Delta P$ (psi)	Correction factor
0.75	1.97
1.5	1.39
<b>3</b>	<b>1.00</b>
3.5	0.91
4	0.85
4.5	0.81

Correction factor for circulation rate ( $f_{rec}$ )

Circulation rate	Correction factor
2	0.77
3	0.90
<b>4</b>	<b>1</b>
6	1.13
8	1.20
10	1.25

**Nominal capacities**
**Selection tables for solenoid or pressure regulator function in wet suction line**

Capacity table at nominal conditions,  
 $Q_N$  [Tons of Refrigeration],  
 Circulation rate = 4,  
 $\Delta p = 3$  psi

**R 22**

Type	Valve body size	$C_v$ (USgal/min)	Evaporating temperature [°F]							
			-60	-40	-20	0	20	40	60	80
ICM20-A33	20	0.23	0.04	0.06	0.07	0.09	0.11	0.12	0.14	0.15
ICM20-A		0.7	0.1	0.2	0.2	0.3	0.3	0.4	0.4	0.5
ICM20-B		2.8	0.5	0.7	0.9	1.1	1.3	1.5	1.7	1.8
ICM20-C		5.3	1.0	1.4	1.7	2.1	2.4	2.8	3.1	3.5
ICM25-A	25	7	1.3	1.8	2.3	2.8	3.2	3.7	4.1	4.6
ICM25-B		14	2.7	3.6	4.6	5.5	6.4	7.4	8.3	9.2
ICM32-A	32	10	1.9	2.6	3.3	3.9	4.6	5.3	5.9	6.5
ICM32-B		20	3.8	5.2	6.5	7.9	9.2	10.5	11.9	13.1
ICM40-A	40	17	3.2	4.4	5.6	6.7	7.8	9.0	10.1	11.1
ICM40-B		30	5.7	7.8	9.8	11.8	13.8	15.8	17.8	19.6
ICM50-A	50	27	5.1	7.0	8.8	10.6	12.4	14.2	16.0	17.7
ICM50-B		46	8.7	12.0	15.0	18.1	21.2	24.2	27.3	30.1
ICM65-A	65	41	8	11	13	16	19	22	24	27
ICM65-B		81	15.4	21.1	26.5	31.9	37.3	42.7	48.0	53.0
ICM100	100	165	30	43	53	65	75	88	98	109
ICM125	125	259	48	68	84	103	118	138	153	171
ICM150	150	430	79	112	139	171	196	229	254	283

**Correction factor for  $\Delta P$  ( $f_{\Delta P}$ )**

$\Delta P$ (psi)	Correction factor
3	1.00
4	0.87
5	0.79
6	0.72
7	0.66
8	0.62

**Correction factor for circulation rate ( $f_{rec}$ )**

Circulation rate	Correction factor
2	0.77
3	0.90
4	1
6	1.13
8	1.20
10	1.25

Nominal capacities

## Selection tables for solenoid or pressure regulator function in dry suction line

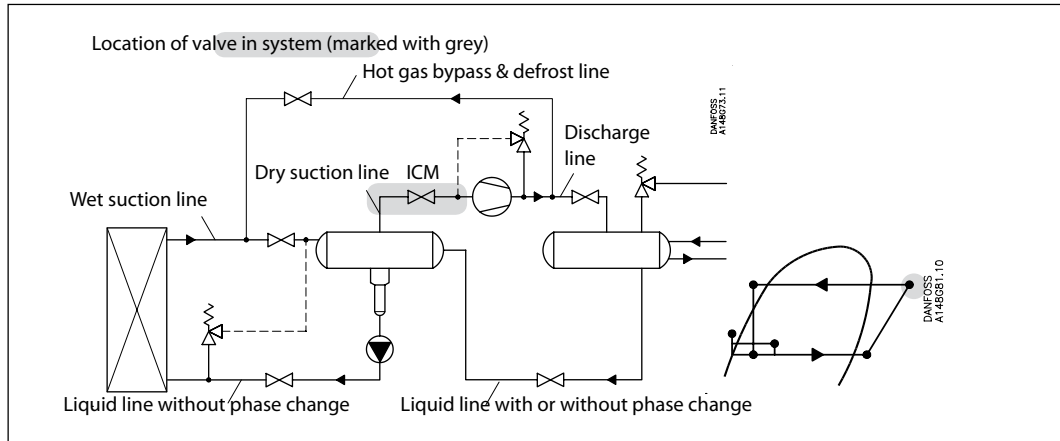

Calculation example (R717 capacities):

An application has following running conditions:

$T_e = 0^\circ\text{F}$   
 $Q_o = 20 \text{ TR}$   
 $T_{liq} = 50^\circ\text{F}$   
 Max.  $\Delta p = 3.5 \text{ psi}$   
 Connection:  $1\frac{1}{4}''$

The capacity table is based on nominal condition ( $\Delta p = 3 \text{ psi}$ ,  $T_{liq} = 90^\circ\text{F}$ )

Therefore the actual capacity must be corrected to nominal condition by means of correction factors.

Correction factor for  $\Delta p$  3.5 psi  $f_{\Delta p} = 0.91$   
 Correction factor for liquid temperature  $f_{T_{liq}} = 0.92$

$$Q_n = Q_o \times f_{\Delta p} \times f_{T_{liq}} = 20 \times 0.91 \times 0.92 = 16.7 \text{ TR}$$

From the capacity table a ICM 32-B with  $Q_n$  capacity 28.2 TR is selected.



Nominal capacities

## Selection tables for solenoid or pressure regulator function in dry suction line

Capacity table at nominal conditions,  
 $Q_N$  [Tons of Refrigeration],  
 $T_{liq} = 90^\circ\text{F}$ ,  
 $\Delta p = 3$  psi  
 Superheating =  $12^\circ\text{F}$

### R 717

Type	Valve body size	$C_v$ (USgal/min)	Evaporating temperature [°F]							
			-60	-40	-20	0	20	40	60	80
ICM20-A33	20	0.23	0.15	0.19	0.25	0.32	0.41	0.50	0.61	0.73
ICM20-A		0.7	0.5	0.6	0.8	1.0	1.2	1.5	1.9	2.2
ICM20-B		2.8	1.9	2.3	3.1	3.9	5.0	6.1	7.4	8.8
ICM20-C		5.3	3.5	4.4	5.8	7.5	9.4	11.6	14.0	16.8
ICM25-A	25	7	4.7	5.8	7.6	9.9	12.4	15.3	18.5	22.1
ICM25-B		14	9.3	11.6	15.3	19.7	24.8	30.6	37.1	44.2
ICM32-A	32	10	6.7	8.3	10.9	14.1	17.7	21.9	26.5	31.6
ICM32-B		20	13.3	16.5	21.9	28.2	35.5	43.8	53.0	63.2
ICM40-A	40	17	11.3	14.0	18.6	23.9	30.1	37.2	45.0	53.7
ICM40-B		30	20.0	24.8	32.8	42.3	53.2	65.6	79.4	94.8
ICM50-A	50	27	18.0	22.3	29.5	38.0	47.9	59.1	71.5	85.3
ICM50-B		46	30.7	38.0	50.3	64.8	81.6	101	122	145
ICM65-A	65	41	28	34	45	58	73	90	109	129
ICM65-B		81	54.0	66.9	88.5	114	144	177	215	256
ICM100	100	165	111	137	181	233	292	360	438	521
ICM125	125	259	174	215	284	365	458	566	687	818
ICM150	150	430	289	357	472	606	761	939	1141	1357

#### Correction factor for $\Delta P$ ( $f_{\Delta P}$ )

$\Delta P$ (psi)	Correction factor
0.75	1.97
1.5	1.39
<b>3</b>	<b>1.00</b>
3.5	0.91
4	0.85
4.5	0.81

#### Correction factor for liquid temperature ( $T_{liq}$ )

Liquid temperature	Correction factor
-10°F	0.82
10°F	0.85
30°F	0.88
50°F	0.92
70°F	0.96
<b>90°F</b>	<b>1.00</b>
110°F	1.04
130°F	1.09

Capacity table at nominal conditions,  $Q_N$  [Tons of Refrigeration],  
 $T_{liq} = 50^\circ\text{F}$ ,  
 $\Delta p = 3$  psi  
 Superheating =  $12^\circ\text{F}$

### R 744

Type	Valve body size	$C_v$ (USgal/min)	Evaporating temperature [°F]							
			-60	-40	-20	0	20	40	60	
ICM20-A33	20	0.23	0.20	0.24	0.30	0.36	0.43	0.50	0.57	
ICM20-A		0.7	0.6	0.7	0.9	1.1	1.3	1.5	1.7	
ICM20-B		2.8	2.4	3.0	3.7	4.4	5.2	6.0	6.9	
ICM20-C		5.3	4.5	5.7	6.9	8.3	9.8	11.4	13.0	
ICM25-A	25	7	6.0	7.5	9.1	11.0	13.0	15.1	17.2	
ICM25-B		14	11.9	14.9	18.3	22.0	26.0	30.2	34.5	
ICM32-A	32	10	8.5	10.7	13.1	15.7	18.5	21.5	24.6	
ICM32-B		20	17.0	21.3	26.1	31.4	37.1	43.1	49.2	
ICM40-A	40	17	14.5	18.1	22.2	26.7	31.5	36.6	41.8	
ICM40-B		30	25.5	32.0	39.2	47.1	55.6	64.6	73.9	
ICM50-A	50	27	23.0	28.8	35.3	42.4	50.1	58.2	66.5	
ICM50-B		46	39.1	49.1	60.1	72.2	85.3	99.1	113	
ICM65-A	65	41	35	44	54	64	76	88	101	
ICM65-B		81	68.9	86.4	106	127	150	175	199	
ICM100	100	165	141	175	215	259	306	355	405	
ICM125	125	259	221	275	338	407	480	558	636	
ICM150	150	430	366	457	561	675	797	926	1057	

#### Correction factor for $\Delta P$ ( $f_{\Delta P}$ )

$\Delta P$ (psi)	Correction factor
0.75	1.97
1.5	1.39
<b>3</b>	<b>1.00</b>
3.5	0.91
4	0.85
4.5	0.81

#### Correction factor for liquid temperature ( $T_{liq}$ )

Liquid temperature	Correction factor
-10°F	0.48
10°F	0.64
30°F	0.88
<b>50°F</b>	<b>1.00</b>

Nominal capacities

Capacity table at nominal conditions,  $Q_N$  [Tons of Refrigeration],  
 $T_{liq} = 90^\circ\text{F}$ ,  
 $\Delta p = 3 \text{ psi}$   
 Superheating =  $12^\circ\text{F}$

## Selection tables for solenoid or pressure regulator function in dry suction line

### R 134a

Type	Valve body size	$C_v$ (USgal/min)	Evaporating temperature [°F]						
			-40	-20	0	20	40	60	80
ICM20-A33	20	0.23	0.05	0.07	0.09	0.12	0.15	0.18	0.23
ICM20-A		0.7	0.2	0.2	0.3	0.4	0.4	0.6	0.7
ICM20-B		2.8	0.6	0.8	1.1	1.4	1.8	2.2	2.7
ICM20-C		5.3	1.1	1.6	2.1	2.7	3.4	4.2	5.2
ICM25-A	25	7	1.5	2.1	2.7	3.5	4.5	5.6	6.9
ICM25-B		14	3.0	4.1	5.4	7.1	9.0	11.2	13.7
ICM32-A	32	10	2.2	2.9	3.9	5.0	6.4	8.0	9.8
ICM32-B		20	4.3	5.9	7.8	10.1	12.8	16.0	19.6
ICM40-A	40	17	3.7	5.0	6.6	8.6	10.9	13.6	16.6
ICM40-B		30	6.5	8.8	11.7	15.1	19.2	23.9	29.4
ICM50-A	50	27	5.8	7.9	10.5	13.6	17.3	21.5	26.4
ICM50-B		46	9.9	13.5	17.9	23.2	29.4	36.7	45.0
ICM65-A	65	41	9	12	16	21	26	33	40
ICM65-B		81	17.4	23.8	31.5	40.8	51.8	64.6	79.3
ICM100	100	165	36	48	65	84	105	132	162
ICM125	125	259	57	76	102	132	165	208	254
ICM150	150	430	95	126	169	219	273	345	421

Correction factor for  $\Delta P$  ( $f_{\Delta P}$ )

$\Delta P$ (psi)	Correction factor
0.75	1.97
1.5	1.39
<b>3</b>	<b>1.00</b>
3.5	0.91
4	0.85
4.5	0.81

Correction factor for liquid temperature ( $T_{liq}$ )

Liquid temperature	Correction factor
-10°F	0.64
10°F	0.68
30°F	0.74
50°F	0.81
70°F	0.89
<b>90°F</b>	<b>1.00</b>
110°F	1.15
130°F	1.35

Capacity table at nominal conditions,  $Q_N$  [Tons of Refrigeration],  
 $T_{liq} = 90^\circ\text{F}$ ,  
 $\Delta p = 3 \text{ psi}$   
 Superheating =  $12^\circ\text{F}$

### R 404A

Type	Valve body size	$C_v$ (USgal/min)	Evaporating temperature [°F]							
			-60	-40	-20	0	20	40	60	80
ICM20-A33	20	0.23	0.04	0.06	0.08	0.10	0.13	0.16	0.20	0.25
ICM20-A		0.7	0.1	0.2	0.2	0.3	0.4	0.5	0.6	0.8
ICM20-B		2.8	0.5	0.7	1.0	1.2	1.6	2.0	2.5	3.0
ICM20-C		5.3	1.0	1.3	1.8	2.4	3.0	3.8	4.7	5.7
ICM25-A	25	7	1.3	1.8	2.4	3.1	4.0	5.0	6.2	7.6
ICM25-B		14	2.6	3.5	4.8	6.2	8.0	10.0	12.4	15.2
ICM32-A	32	10	1.8	2.5	3.4	4.5	5.7	7.2	8.9	10.8
ICM32-B		20	3.7	5.1	6.8	8.9	11.4	14.3	17.8	21.7
ICM40-A	40	17	3.1	4.3	5.8	7.6	9.7	12.2	15.1	18.4
ICM40-B		30	5.5	7.6	10.2	13.4	17.1	21.5	26.6	32.5
ICM50-A	50	27	4.9	6.8	9.2	12.0	15.4	19.4	24.0	29.3
ICM50-B		46	8.4	11.6	15.7	20.5	26.2	33.0	40.8	49.9
ICM65-A	65	41	7	10	14	18	23	29	36	45
ICM65-B		81	14.8	20.5	27.6	36.1	46.2	58.1	71.9	87.8
ICM100	100	165	30	42	56	73	94	118	146	179
ICM125	125	259	47	66	87	115	148	186	229	282
ICM150	150	430	77	110	145	191	245	308	381	467

Correction factor for  $\Delta P$  ( $f_{\Delta P}$ )

$\Delta P$ (psi)	Correction factor
0.75	1.97
1.5	1.39
<b>3</b>	<b>1.00</b>
3.5	0.91
4	0.85
4.5	0.81

Correction factor for liquid temperature ( $T_{liq}$ )

Liquid temperature	Correction factor
-10°F	0.52
10°F	0.57
30°F	0.63
50°F	0.72
70°F	0.83
<b>90°F</b>	<b>1.00</b>
110°F	1.29
130°F	1.92

**Nominal capacities**

Capacity table at nominal conditions,  $Q_N$  [Tons of Refrigeration],  
 $T_{liq} = 90^\circ\text{F}$ ,  
 $\Delta p = 3 \text{ psi}$   
 Superheating =  $12^\circ\text{F}$

Selection tables for solenoid or pressure regulator function in dry suction line

**R 22**

Type	Valve body size	$C_v$ (USgal/min)	Evaporating temperature [°F]							
			-60	-40	-20	0	20	40	60	80
ICM20-A33	20	0.23	0.06	0.07	0.10	0.12	0.16	0.19	0.23	0.27
ICM20-A		0.7	0.2	0.2	0.3	0.4	0.5	0.6	0.7	0.8
ICM20-B		2.8	0.7	0.9	1.2	1.5	1.9	2.3	2.8	3.3
ICM20-C		5.3	1.3	1.7	2.2	2.9	3.6	4.3	5.2	6.2
ICM25-A	25	7	1.7	2.3	3.0	3.8	4.7	5.7	6.9	8.2
ICM25-B		14	3.4	4.6	5.9	7.5	9.4	11.5	13.8	16.4
ICM32-A	32	10	2.4	3.3	4.2	5.4	6.7	8.2	9.9	11.7
ICM32-B		20	4.9	6.5	8.5	10.8	13.4	16.4	19.8	23.5
ICM40-A	40	17	4.1	5.5	7.2	9.2	11.4	13.9	16.8	20.0
ICM40-B		30	7.3	9.8	12.7	16.1	20.1	24.6	29.6	35.2
ICM50-A	50	27	6.6	8.8	11.4	14.5	18.1	22.1	26.7	31.7
ICM50-B		46	11.2	15.0	19.5	24.8	30.8	37.7	45.4	54.0
ICM65-A		41	10	13	17	22	28	34	41	48
ICM65-B	65	81	19.7	26.4	34.3	43.6	54.3	66.4	80.0	95.1
ICM100	100	165	41	53	70	89	111	136	163	193
ICM125	125	259	64	83	110	140	175	213	256	303
ICM150	150	430	106	139	182	233	290	353	425	503

Correction factor for liquid temperature ( $T_{liq}$ )

Liquid temperature	Correction factor
-10°F	0.73
10°F	0.77
30°F	0.82
50°F	0.87
70°F	0.93
<b>90°F</b>	<b>1.00</b>
110°F	1.09
130°F	1.20

Correction factor for  $\Delta P$  ( $f_{\Delta P}$ )

$\Delta P$ (psi)	Correction factor
<b>3</b>	<b>1.00</b>
4	0.87
5	0.79
6	0.72
7	0.66
8	0.62

## Selection tables for discharge line

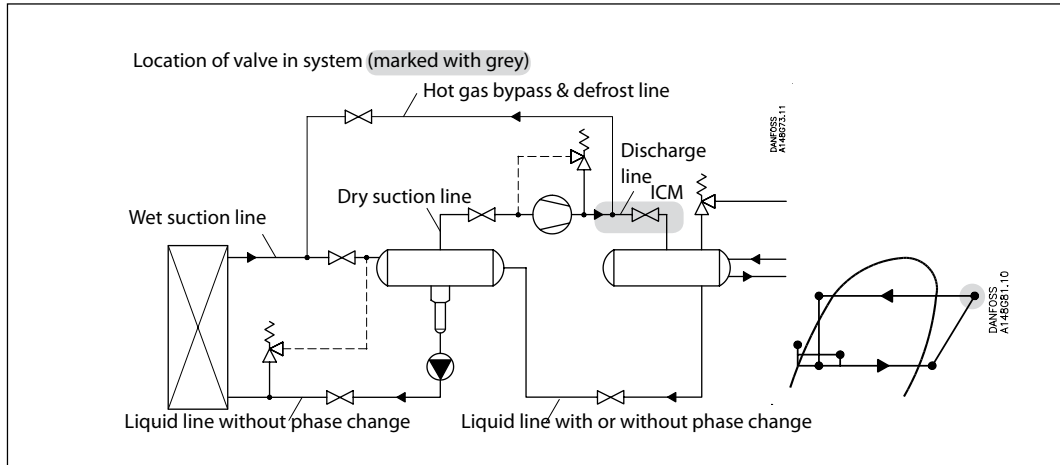

### Calculation example (R717 capacities):

An application has following running conditions:

- $T_e = 0^\circ\text{F}$
- $Q_o = 8 \text{ TR}$
- $T_{liq} = 50^\circ\text{F}$
- Max.  $\Delta p = 4.5 \text{ psi}$
- $T_{disch.} = 120^\circ\text{F}$
- Connection:  $\frac{3}{4}''$

The capacity table is based on nominal condition ( $\Delta p = 3 \text{ psi}$ ,  $T_{liq} = 90^\circ\text{F}$ ,  $P_{disch.} = 185 \text{ psi}$ ,  $T_{disch.} = 180^\circ\text{F}$ )

Therefore the actual capacity must be corrected to nominal condition by means of correction factors.

- Correction factor for  $\Delta p = 4.5 \text{ psi}$   $f_{\Delta p} = 0.81$
- Correction factor for liquid temperature  $f_{T_{liq}} = 0.92$
- Correction factor for  $T_{disch.} = 120^\circ\text{F}$ ,  $f_{disch.} = 0.95$

$$Q_n = Q_o \times f_{\Delta p} \times f_{T_{liq}} \times f_{disch.} = 8 \times 0.81 \times 0.92 \times 0.95 = 5.7 \text{ TR}$$

From the capacity table a ICM 20-B with  $Q_n$  capacity 8.4 TR is selected.

Nominal capacities

Selection tables for discharge line

Capacity table at nominal conditions,  
 $Q_N$  [Tons of Refrigeration],  
 $T_{liq} = 90^\circ\text{F}$ ,  
 $\Delta p = 3 \text{ psi}$ ,  
 $P_{disch.} = 185 \text{ psi}$ ,  
 $T_{disch.} = 180^\circ\text{F}$   
 Superheating =  $12^\circ\text{F}$

R 717

Type	Valve body size	$C_v$ (USgal/min)	Evaporating temperature [°F]							
			-60	-40	-20	0	20	40	60	80
ICM20-A33	20	0.23	0.66	0.67	0.68	0.69	0.70	0.71	0.71	0.72
ICM20-A		0.7	2.0	2.0	2.1	2.1	2.1	2.2	2.2	2.2
ICM20-B		2.8	8.0	8.2	8.3	8.4	8.5	8.6	8.7	8.7
ICM20-C		5.3	15.2	15.4	15.7	15.9	16.1	16.3	16.4	16.5
ICM25-A	25	7	20.0	20.4	20.7	21.0	21.3	21.5	21.7	21.8
ICM25-B		14	40.1	40.8	41.5	42.0	42.6	43.0	43.4	43.6
ICM32-A	32	10	28.6	29.1	29.6	30.0	30.4	30.7	31.0	31.2
ICM32-B		20	57.3	58.3	59.3	60.0	60.9	61.5	62.0	62.3
ICM40-A	40	17	48.7	49.5	50.4	51.0	51.7	52.3	52.7	53.0
ICM40-B		30	85.9	87.4	88.9	90.0	91.3	92.2	93.0	93.5
ICM50-A	50	27	77.3	78.7	80.0	81.0	82.2	83.0	83.7	84.2
ICM50-B		46	132	134	136	138	140	141	143	143
ICM65-A	65	41	117	119	122	123	125	126	127	128
ICM65-B		81	232	236	240	243	247	249	251	253
ICM100	100	165	472	480	489	495	501	508	512	514
ICM125	125	259	741	754	768	777	787	797	804	807
ICM150	150	430	1231	1251	1275	1290	1307	1324	1335	1341

Correction factor for  $\Delta P$  ( $f_{\Delta P}$ )

$\Delta P$ (psi)	Correction factor
0.75	1.97
1.5	1.39
<b>3</b>	<b>1.00</b>
3.5	0.91
4	0.85
4.5	0.81

Correction factor for discharge temperature ( $T_{disch.}$ )

Discharge temperature	Correction factor
120°F	0.95
140°F	0.97
<b>180°F</b>	<b>1.00</b>
200°F	1.02
210°F	1.02
230°F	1.04
250°F	1.05

Correction factor for liquid temperature ( $T_{liq}$ )

Liquid temperature	Correction factor
-10°F	0.82
10°F	0.85
30°F	0.88
50°F	0.92
70°F	0.96
<b>90°F</b>	<b>1.00</b>
110°F	1.04
130°F	1.09

Capacity table at nominal conditions,  
 $Q_N$  [Tons of Refrigeration],  
 $T_{liq} = 50^\circ\text{F}$ ,  
 $\Delta p = 3 \text{ psi}$ ,  
 $P_{disch.} = 185 \text{ psi}$ ,  
 $T_{disch.} = 180^\circ\text{F}$   
 Superheating =  $12^\circ\text{F}$

R 744

Type	Valve body size	$C_v$ (USgal/min)	Evaporating temperature [°F]							
			-60	-40	-20	0	20	40	60	
ICM20-A33	20	0.23	0.40	0.41	0.42	0.42	0.42	0.41	0.41	
ICM20-A		0.7	1.2	1.3	1.3	1.3	1.3	1.2	1.2	
ICM20-B		2.8	4.9	5.0	5.1	5.1	5.1	5.0	5.0	
ICM20-C		5.3	9.3	9.5	9.6	9.7	9.6	9.5	9.5	
ICM25-A	25	7	12.3	12.6	12.7	12.8	12.7	12.5	12.5	
ICM25-B		14	24.7	25.1	25.4	25.5	25.4	25.0	25.0	
ICM32-A	32	10	17.6	18.0	18.1	18.2	18.1	17.8	17.8	
ICM32-B		20	35.3	35.9	36.3	36.5	36.3	35.7	35.7	
ICM40-A	40	17	30.0	30.5	30.9	31.0	30.9	30.3	30.3	
ICM40-B		30	52.9	53.9	54.4	54.7	54.4	53.5	53.5	
ICM50-A	50	27	47.6	48.5	49.0	49.2	49.0	48.2	48.2	
ICM50-B		46	81.1	82.6	83.5	83.9	83.5	82.1	82.1	
ICM65-A	65	41	72	74	75	75	75	73	73	
ICM65-B		81	143	145	147	148	147	145	145	
ICM100	100	165	290	297	300	301	300	294	294	
ICM125	125	259	455	466	471	473	471	461	461	
ICM150	150	430	756	774	782	786	782	765	765	

Correction factor for  $\Delta P$  ( $f_{\Delta P}$ )

$\Delta P$ (psi)	Correction factor
0.75	1.97
1.5	1.39
<b>3</b>	<b>1.00</b>
3.5	0.91
4	0.85
4.5	0.81

Correction factor for discharge temperature ( $T_{disch.}$ )

Discharge temperature	Correction factor
120°F	0.95
140°F	0.97
<b>180°F</b>	<b>1.00</b>
200°F	1.02
210°F	1.02
230°F	1.04
250°F	1.05

Correction factor for liquid temperature ( $T_{liq}$ )

Liquid temperature	Correction factor
-10°F	0.48
10°F	0.64
30°F	0.88
<b>50°F</b>	<b>1.00</b>

**Nominal capacities**

Capacity table at nominal conditions,  
 $Q_N$  [Tons of Refrigeration],  
 $T_{liq} = 90^\circ\text{F}$ ,  
 $\Delta p = 3$  psi,  
 $P_{disch.} = 120$  psi,  
 $T_{disch.} = 180^\circ\text{F}$   
 Superheating =  $12^\circ\text{F}$

**Selection tables for discharge line**

**R 134a**

Type	Valve body size	$C_v$ (USgal/min)	Evaporating temperature [°F]						
			-40	-20	0	20	40	60	80
ICM20-A33	20	0.23	0.17	0.18	0.19	0.19	0.20	0.21	0.22
ICM20-A		0.7	0.5	0.5	0.6	0.6	0.6	0.6	0.7
ICM20-B		2.8	2.0	2.1	2.3	2.4	2.5	2.6	2.7
ICM20-C		5.3	3.9	4.1	4.3	4.5	4.7	4.9	5.0
ICM25-A	25	7	5.1	5.4	5.6	5.9	6.2	6.4	6.7
ICM25-B		14	10.2	10.7	11.3	11.8	12.3	12.8	13.3
ICM32-A	32	10	7.3	7.7	8.0	8.4	8.8	9.2	9.5
ICM32-B		20	14.5	15.3	16.1	16.9	17.6	18.3	19.0
ICM40-A	40	17	12.4	13.0	13.7	14.3	15.0	15.6	16.2
ICM40-B		30	21.8	23.0	24.1	25.3	26.4	27.5	28.5
ICM50-A	50	27	19.6	20.7	21.7	22.8	23.8	24.7	25.7
ICM50-B		46	33.4	35.3	37.0	38.8	40.5	42.1	43.7
ICM65-A	65	41	30	31	33	35	36	37	39
ICM65-B		81	58.9	62.1	65.2	68.3	71.3	74.2	77.0
ICM100	100	165	120	126	134	140	145	151	158
ICM125	125	259	188	197	210	219	228	236	248
ICM150	150	430	312	328	348	364	379	393	411

Correction factor for  $\Delta P$  ( $f_{\Delta P}$ )

$\Delta P$ (psi)	Correction factor
0.75	1.97
1.5	1.39
<b>3</b>	<b>1.00</b>
3.5	0.91
4	0.85
4.5	0.81

Correction factor for discharge temperature ( $T_{disch.}$ ).

Discharge temperature	Correction factor
120°F	0.95
140°F	0.97
<b>180°F</b>	<b>1.00</b>
200°F	1.02
210°F	1.02
230°F	1.04
250°F	1.05

Correction factor for liquid temperature ( $T_{liq}$ )

Liquid temperature	Correction factor
-10°F	0.64
10°F	0.68
30°F	0.74
50°F	0.81
70°F	0.89
<b>90°F</b>	<b>1.00</b>
110°F	1.15
130°F	1.35

**R 404A**

Capacity table at nominal conditions,  
 $Q_N$  [Tons of Refrigeration],  
 $T_{liq} = 90^\circ\text{F}$ ,  
 $\Delta p = 3$  psi,  
 $P_{disch.} = 120$  psi,  
 $T_{disch.} = 180^\circ\text{F}$   
 Superheating =  $12^\circ\text{F}$

Typ	Valve body size	$C_v$ (USgal/min)	Evaporating temperature [°F]							
			-60	-40	-20	0	20	40	60	80
ICM20-A33	20	0.23	0.15	0.16	0.17	0.19	0.20	0.21	0.22	0.23
ICM20-A		0.7	0.5	0.5	0.5	0.6	0.6	0.6	0.7	0.7
ICM20-B		2.8	1.8	2.0	2.1	2.3	2.4	2.5	2.7	2.8
ICM20-C		5.3	3.5	3.7	4.0	4.3	4.6	4.8	5.0	5.2
ICM25-A	25	7	4.6	5.0	5.3	5.7	6.0	6.4	6.6	6.9
ICM25-B		14	9.2	9.9	10.6	11.4	12.0	12.7	13.3	13.8
ICM32-A	32	10	6.5	7.1	7.6	8.1	8.6	9.1	9.5	9.9
ICM32-B		20	13.1	14.1	15.2	16.2	17.2	18.1	19.0	19.7
ICM40-A	40	17	11.1	12.0	12.9	13.8	14.6	15.4	16.1	16.8
ICM40-B		30	19.6	21.2	22.8	24.3	25.8	27.2	28.5	29.6
ICM50-A	50	27	17.7	19.1	20.5	21.9	23.2	24.5	25.6	26.6
ICM50-B		46	30.1	32.5	35.0	37.3	39.6	41.7	43.7	45.4
ICM65-A	65	41	27	29	31	33	35	37	39	41
ICM65-B		81	53.0	57.3	61.6	65.7	69.7	73.5	76.9	79.9
ICM100	100	165	109	117	124	135	142	149	157	163
ICM125	125	259	171	183	195	211	223	234	247	256
ICM150	150	430	283	304	324	351	370	388	410	425

Correction factor for  $\Delta P$  ( $f_{\Delta P}$ )

$\Delta P$ (psi)	Correction factor
0.75	1.97
1.5	1.39
<b>3</b>	<b>1.00</b>
3.5	0.91
4	0.85
4.5	0.81

Correction factor for discharge temperature ( $T_{disch.}$ ).

Discharge temperature	Correction factor
120°F	0.95
140°F	0.97
<b>180°F</b>	<b>1.00</b>
200°F	1.02
210°F	1.02
230°F	1.04
250°F	1.05

Correction factor for liquid temperature ( $T_{liq}$ )

Liquid temperature	Correction factor
-10°F	0.52
10°F	0.57
30°F	0.63
50°F	0.72
70°F	0.83
<b>90°F</b>	<b>1.00</b>
110°F	1.29
130°F	1.92

**Nominal capacities**
**Selection tables for discharge line**

 Capacity table at nominal conditions, **R 22**
 $Q_N$  [Tons of Refrigeration],

 $T_{liq} = 90^\circ\text{F}$ ,

 $\Delta p = 3$  psi,

 $P_{disch.} = 120$  psi,

 $T_{disch.} = 180^\circ\text{F}$ 

 Superheating =  $12^\circ\text{F}$ 

Typ	Valve body size	C <sub>v</sub> (USgal/min)	Evaporating temperature [°F]							
			-60	-40	-20	0	20	40	60	80
ICM20-A33	20	0.23	0.21	0.22	0.23	0.23	0.24	0.24	0.25	0.26
ICM20-A		0.7	0.6	0.7	0.7	0.7	0.7	0.7	0.8	0.8
ICM20-B		2.8	2.6	2.6	2.7	2.8	2.9	3.0	3.0	3.1
ICM20-C		5.3	4.8	5.0	5.2	5.3	5.5	5.6	5.8	5.9
ICM25-A	25	7	6.4	6.6	6.8	7.1	7.3	7.4	7.6	7.8
ICM25-B		14	12.8	13.2	13.7	14.1	14.5	14.9	15.2	15.6
ICM32-A	32	10	9.1	9.5	9.8	10.1	10.4	10.6	10.9	11.1
ICM32-B		20	18.2	18.9	19.6	20.2	20.7	21.3	21.8	22.2
ICM40-A	40	17	15.5	16.1	16.6	17.1	17.6	18.1	18.5	18.9
ICM40-B		30	27.4	28.4	29.3	30.3	31.1	31.9	32.7	33.3
ICM50-A	50	27	24.6	25.5	26.4	27.2	28.0	28.7	29.4	30.0
ICM50-B		46	42.0	43.5	45.0	46.4	47.7	49.0	50.1	51.1
ICM65-A	65	41	37	39	40	41	42	43	45	46
ICM65-B		81	73.9	76.6	79.2	81.7	84.0	86.2	88.2	90.0
ICM100	100	165	150	157	161	166	171	175	180	184
ICM125	125	259	235	246	253	261	268	274	283	288
ICM150	150	430	391	408	421	433	445	455	470	479

**Correction factor for  $\Delta P$  ( $f_{\Delta P}$ )**

$\Delta P$ (psi)	Correction factor
<b>3</b>	<b>1.00</b>
4	0.87
5	0.79
6	0.72
7	0.66
8	0.62

**Correction factor for discharge temperature ( $T_{disch.}$ )**

Discharge temperature	Correction factor
120°F	0.95
140°F	0.97
<b>180°F</b>	<b>1.00</b>
200°F	1.02
210°F	1.02
230°F	1.04
250°F	1.05

**Correction factor for liquid temperature ( $T_{liq.}$ )**

Liquid temperature	Correction factor
-10°F	0.73
10°F	0.77
30°F	0.82
50°F	0.87
70°F	0.93
<b>90°F</b>	<b>1.00</b>
110°F	1.09
130°F	1.20

## ICM 20 / ICAD 600

### Ordering complete valve with actuator motor

Valve type	Connection type/size	Code number*
ICM 20-A33	3/4" SOC	027H1043NA
ICM 20-A	3/4" FPT	027H1055NA
ICM 20-A	3/4" SOC	027H1040NA
ICM 20-A	3/4" BW	027H1035NA
ICM 20-A	1" BW	027H1023NA
ICM 20-A	5/8" ODS	027H1015NA
ICM 20-A	7/8" ODS	027H1050NA
ICM 20-B66	3/4" SOC	027H1044NA
ICM 20-B	3/4" FPT	027H1056NA
ICM 20-B	3/4" SOC	027H1041NA
ICM 20-B	3/4" BW	027H1036NA
ICM 20-B	1" BW	027H1024NA
ICM 20-B	5/8" ODS	027H1016NA
ICM 20-B	7/8" ODS	027H1051NA
ICM 20-C	3/4" FPT	027H1057NA
ICM 20-C	3/4" SOC	027H1042NA
ICM 20-C	3/4" BW	027H1037NA
ICM 20-C	1" BW	027H1025NA
ICM 20-C	5/8" ODS	027H1017NA
ICM 20-C	7/8" ODS	027H1052NA

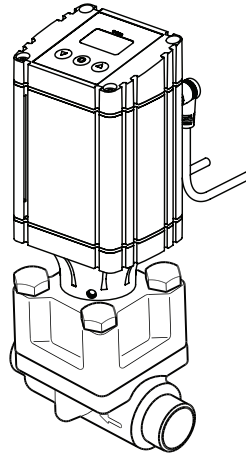

BW= Butt-weld ANSI ; SOC = Socket weld ANSI ; ODS = Solder ANSI ; FPT = Female Pipe Thread  
 \*Code number for ICM with ICAD motor actuator with 9.8 ft. (3 m) cables

### Multi-function tool for ICM 20-32



The multi-function tool can be used for:  
 - Manually operating motorized valve type ICM  
 - Removing the ICS function module  
 - Operating the ICS manual spindle  
 For further information please see the instruction **PIHU<sup>®</sup>A**.

### Protection cap ICAD 600/900/1200

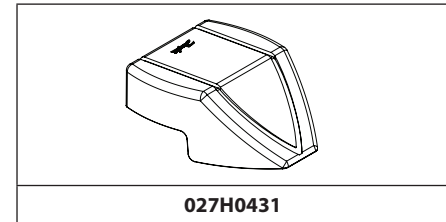

### ICM 20 valve body

Connection size/type	Code Number
3/4 in. SOC	027H1151
3/4 in. FPT	027H1157
3/4 in. BW	027H1148
1 in. BW	027H1166
5/8 in. ODS	027H1129
7/8 in. ODS	027H1160

### ICM 20 Function module / top cover

Description	Code Number
ICM 20-A33	027H1186 *)
ICM 20-A	027H1180 *)
ICM 20-B66	027H1194 *)
ICM 20-B	027H1181 *)
ICM 20-C	027H1182 *)

\*) Including:  
 Bolts and O-ring (for assembly with ICV valve body)  
 Seat and O-ring (for seat to be mounted in ICV valve body)

### ICAD 600 actuator

Description	Code Number
ICAD 600 without cables	027H9100
Cable set, 3 m (9.8 ft) for ICAD*	027H0438

\* see accessories for other lengths

### Spare parts

Spare Parts	Code Number
Service kit	027H1190



# ICM 25 / ICAD 600

## Ordering complete valve with actuator motor

Valve type	Connection type/size	Code number*
ICM 25-A	1" FPT	027H2282NA
ICM 25-A	1" SOC	027H2004NA
ICM 25-A	1" BW	027H2002NA
ICM 25-A	1-1/4" BW	027H2276NA
ICM 25-A	7/8" ODS	027H2010NA
ICM 25-A	1-1/8" ODS	027H2012NA
ICM 25-A	1-3/8" ODS	027H2014NA
ICM 25-B	3/4" FPT	027H2281NA
ICM 25-B	1" FPT	027H2283NA
ICM 25-B	3/4" SOC	027H2279NA
ICM 25-B	1" SOC	027H2005NA
ICM 25-B	3/4" BW	027H2275NA
ICM 25-B	1" BW	027H2003NA
ICM 25-B	1-1/4" BW	027H2277NA
ICM 25-B	7/8" ODS	027H2011NA
ICM 25-B	1-1/8" ODS	027H2013NA
ICM 25-B	1-3/8" ODS	027H2015NA

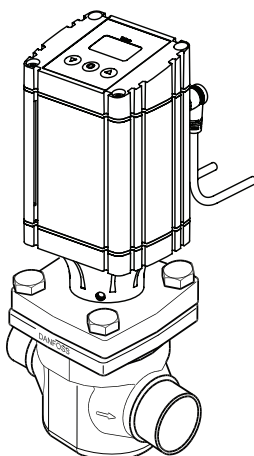

BW= Butt-weld ANSI ; SOC = Socket weld ANSI ; ODS = Solder ANSI ; FPT = Female Pipe Thread  
 \*Code number for ICM with ICAD motor actuator with 9.8 ft. (3 m) cables

## Multi-function tool for ICM 20-32



The multi-function tool can be used for:  
 - Manually operating motorized valve type ICM  
 - Removing the ICS function module  
 - Operating the ICS manual spindle  
 For further information please see the instruction **PIHU0A**.

## Protection cap ICAD 600/900/1200

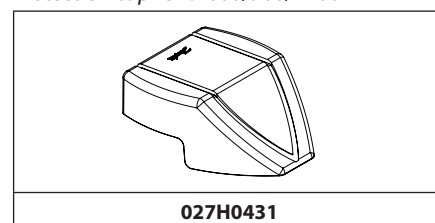

## ICM 25 valve body

Connection size/type	Code Number
3/4 in. SOC	<b>027H2132</b>
1 in. SOC	<b>027H2122</b>
3/4 in. FPT	<b>027H2133</b>
1 in. FPT	<b>027H2127</b>
3/4 in. BW	<b>027H2131</b>
1 in. BW	<b>027H2121</b>
1-1/4 in. BW	<b>027H2130</b>
7/8 in. ODS	<b>027H2125</b>
1-1/8 in. ODS	<b>027H2126</b>
1-3/8 in. ODS	<b>027H2134</b>

## ICM 25 Function module / top cover

Description	Code Number
ICM 25-A	<b>027H2180</b> *)
ICM 25-B	<b>027H2181</b> *)

\*) Including gaskets and O-rings

## ICAD 600 actuator

Description	Code Number
ICAD 600 without cables	<b>027H9100</b>
Cable set, 3 m (9.8 ft) for ICAD*	<b>027H0438</b>

\* see accessories for other lengths

## Spare parts

Spare Parts	Code Number
Service kit	<b>027H2220</b>

# ICM 32 / ICAD 600

## Ordering complete valve with actuator motor

Valve type	Connection type/size	Code number*
ICM 32-A	1-1/4" SOC	<b>027H3004NA</b>
ICM 32-A	1-1/4" BW	<b>027H3002NA</b>
ICM 32-A	1-1/2" BW	<b>027H3014NA</b>
ICM 32-A	1-3/8" ODS	<b>027H3006NA</b>
ICM 32-A	1-5/8" ODS	<b>027H3008NA</b>
ICM 32-B	1-1/4" SOC	<b>027H3005NA</b>
ICM 32-B	1-1/4" BW	<b>027H3003NA</b>
ICM 32-B	1-1/2" BW	<b>027H3015NA</b>
ICM 32-B	1-3/8" ODS	<b>027H3007NA</b>

BW= Butt-weld ANSI ; SOC = Socket weld ANSI ;  
 ODS = Solder ANSI ; FPT = Female Pipe Thread  
 \* Code number for ICM with ICAD motor actuator  
 with 9.8 ft. (3 m) cables

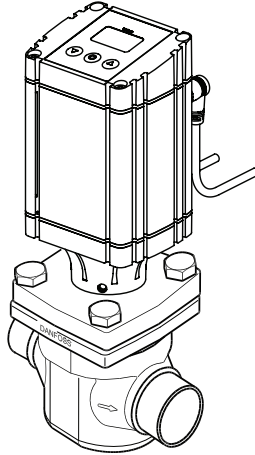

## Multi-function tool for ICM 20-32



**027H0180**

The multi-function tool can be used for:  
 - Manually operating motorized valve type ICM  
 - Removing the ICS function module  
 - Operating the ICS manual spindle  
 For further information please see the instruction **PIHU<sup>®</sup>A**.

## Protection cap ICAD 600/900/1200

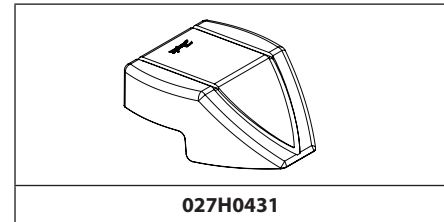

**027H0431**

## ICM 32 valve body

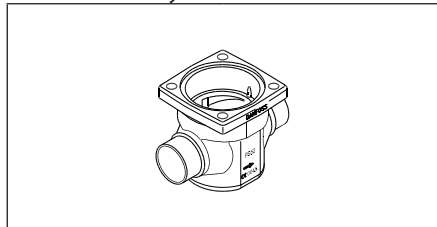

Connection size/type	Code Number
1-1/4 in. SOC	<b>027H3122</b>
1-1/4 in. BW	<b>027H3121</b>
1-1/2 in. BW	<b>027H3126</b>
1-3/8 in. ODS	<b>027H3123</b>
1-5/8 in. ODS	<b>027H3127</b>

## ICM 32 Function module / top cover

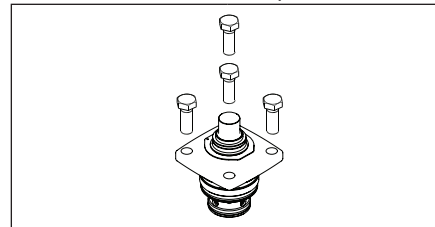

Description	Code Number
ICM 32-A	<b>027H3180 *)</b>
ICM 32-B	<b>027H3181 *)</b>

\*) Including gaskets and O-rings

## ICAD 600 actuator

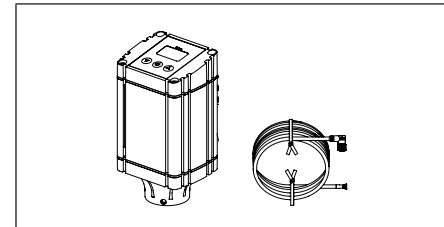

Description	Code Number
ICAD 600 without cables	<b>027H9100</b>
Cable set, 3 m (9.8 ft) for ICAD*	<b>027H0438</b>

\* see accessories for other lengths

## Spare parts

Spare Parts	Code Number
Service kit	<b>027H3220</b>

# ICM 40 / ICAD 900 / ICAD 1200

## Ordering complete valve with actuator motor

Valve type	Connection type/size	Code number with ICAD 900*	Code number with ICAD 1200*
ICM 40-A	1-1/2" SOC	027H4004NA	027H4004NE
ICM 40-A	1-1/2" BW	027H4002NA	027H4002NE
ICM 40-A	2" BW	027H4012NA	027H4012NE
ICM 40-A	1-5/8" ODS	027H4006NA	027H4006NE
ICM 40-B	1-1/2" SOC	027H4005NA	027H4005NE
ICM 40-B	1-1/2" BW	027H4003NA	027H4003NE
ICM 40-B	2" BW	027H4013NA	027H4013NE
ICM 40-B	1-5/8" ODS	027H4007NA	027H4007NE

BW= Butt-weld ANSI ; SOC = Socket weld ANSI ; ODS = Solder ANSI ; FPT = Female Pipe Thread  
 \* Code number for ICM with ICAD motor actuator with 9.8 ft. (3 m) cables

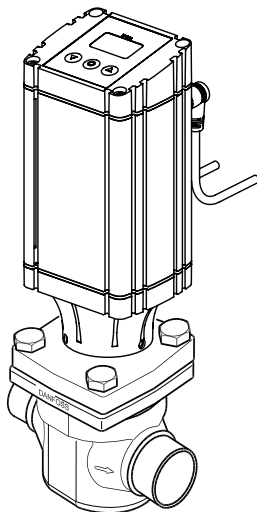

## Multi-function tool for ICM 40-65



The multi-function tool can be used for:  
 - Manually operating motorized valve type ICM  
 - Removing the ICS function module  
 - Operating the ICS manual spindle  
 For further information please see the instruction **PIHU0A**.

## Protection cap ICAD 600/900/1200

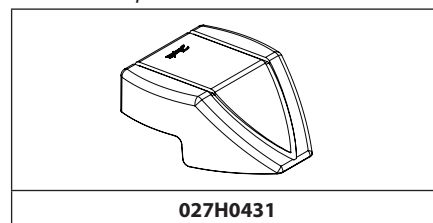

## ICM 40 valve body

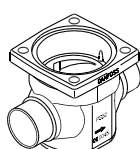

Connection size/type	Code Number
1-1/2 in. SOC	027H4122
1-1/2 in. BW	027H4121
2 in. BW	027H4127
1-5/8 in. ODS	027H4124

## ICM 40 Function module / top cover

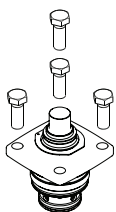

Description	Code Number
ICM 40-A	027H4180 *)
ICM 40-B	027H4181 *)

\*) Including gaskets and O-rings

## ICAD 900/1200 actuator

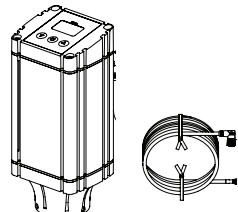

Description	Code Number
ICAD 900 without cables	027H9101
ICAD 1200 without cables	027H9102
Cable set, 3 m (9.8 ft) for ICAD*	027H0438

\* see accessories for other lengths

## Spare parts

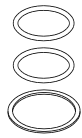

Spare Parts	Code Number
Service kit	027H4220

# ICM 50 / ICAD 900 / ICAD 1200

## Ordering complete valve with actuator motor

Valve type	Connection type/size	Code number with ICAD 900*	Code number with ICAD 1200*
ICM 50-A	2" SOC	027H5004NA	027H5004NE
ICM 50-A	2" BW	027H5002NA	027H5002NE
ICM 50-A	2-1/2" BW	027H5010NA	027H5010NE
ICM 50-A	2-1/8" ODS	027H5006NA	027H5006NE
ICM 50-B	2" SOC	027H5005NA	027H5005NE
ICM 50-B	2" BW	027H5003NA	027H5003NE
ICM 50-B	2-1/2" BW	027H5011NA	027H5011NE
ICM 50-B	2-1/8" ODS	027H5007NA	027H5007NE

BW= Butt-weld ANSI ; SOC = Socket weld ANSI ;  
 ODS = Solder ANSI ; FPT = Female Pipe Thread  
 \* Code number for ICM with ICAD motor actuator with 9.8 ft. (3 m) cables

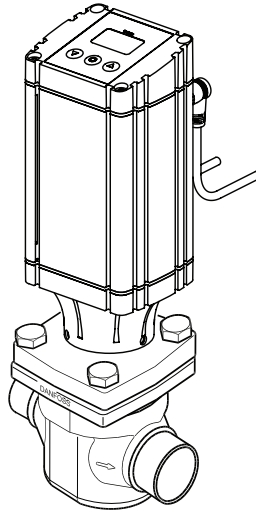

## Multi-function tool for ICM 40-65

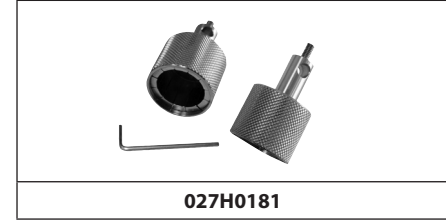

The multi-function tool can be used for:  
 - Manually operating motorized valve type ICM  
 - Removing the ICS function module  
 - Operating the ICS manual spindle  
 For further information please see the instruction **PIHU<sup>®</sup>A**.

## Protection cap ICAD 600/900/1200

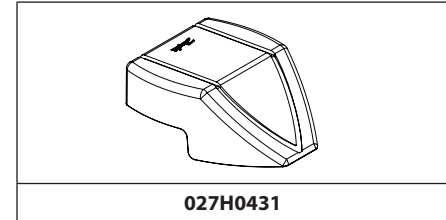

## ICM 50 valve body

Connection size/type	Code Number
2 in. SOC	027H5122
2 in. BW	027H5121
2-1/2 in. BW	027H5125
2-1/8 in. ODS	027H5123

## ICM 50 Function module / top cover

Description	Code Number
ICM 50-A	027H5180 *)
ICM 50-B	027H5181 *)

\*) Including gaskets and O-rings

## ICAD 900/1200 actuator

Description	Code Number
ICAD 900 without cables	027H9101
ICAD 1200 without cables	027H9102
Cable set, 3 m (9.8 ft) for ICAD*	027H0438

\* see accessories for other lengths

## Spare parts

Spare Parts	Code Number
Service kit	027H5220

# ICM 65 / ICAD 900 / ICAD 1200

## Ordering complete valve with actuator motor

Valve type	Connection type/size	Code number with ICAD 900*	Code number with ICAD 1200*
ICM 65-A	2-1/2" SOC	027H6004NA	027H6004NE
ICM 65-A	2-1/2" BW	027H6012NA	027H6012NE
ICM 65-A	3" BW	027H6002NA	027H6002NE
ICM 65-A	2-5/8" ODS	027H6006NA	027H6006NE
ICM 65-B	2-1/2" SOC	027H6005NA	027H6005NE
ICM 65-B	2-1/2" BW	027H6003NA	027H6003NE
ICM 65-B	3" BW	027H6013NA	027H6013NE
ICM 65-B	2-5/8" ODS	027H6007NA	027H6007NE

BW= Butt-weld ANSI ; SOC = Socket weld ANSI ; ODS = Solder ANSI ; FPT = Female Pipe Thread  
 \* Code number for ICM with ICAD motor actuator with 9.8 ft. (3 m) cables

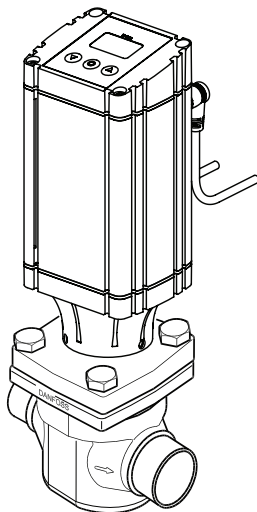

## Multi-function tool for ICM 40-65

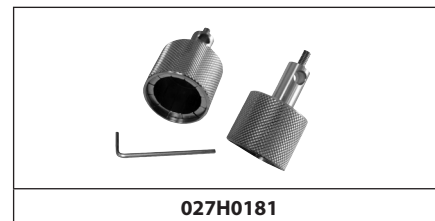

The multi-function tool can be used for:  
 - Manually operating motorized valve type ICM  
 - Removing the ICS function module  
 - Operating the ICS manual spindle  
 For further information please see the instruction PIHU<sup>®</sup>A.

## Protection cap ICAD 600/900/1200

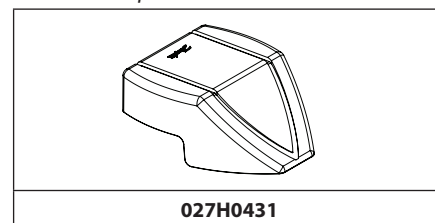

## ICM 65 valve body

Connection size/type	Code Number
2-1/2 in. SOC	027H6123
2-1/2 in. BW	027H6121
3 in. BW	027H6127
2-5/8 in. ODS	027H6125

## ICM 65 Function module / top cover

Description	Code Number
ICM 65-A	027H6180 *)
ICM 65-B	027H6181 *)

\*) Including gaskets and O-rings

## ICAD 900/1200 actuator

Description	Code Number
ICAD 900 without cables	027H9101
ICAD 1200 without cables	027H9102
Cable set, 3 m (9.8 ft) for ICAD*	027H0438

\* see accessories for other lengths

## Spare parts

Spare Parts	Code Number
Service kit	027H6220

## ICM 100-125-150

### Ordering complete valve without actuator

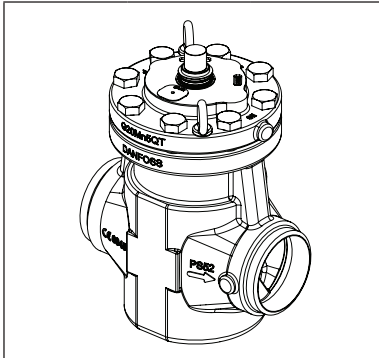

Valve type	Connection type/size	Code number*
ICM 100-B	4" BW	<b>027H7131</b>
ICM 125-B	5" BW	<b>027H7151</b>
ICM 150-B	6" BW	<b>027H7171</b>

\* Code number for ICM valve only.  
ICAD 1200 must be ordered separately.

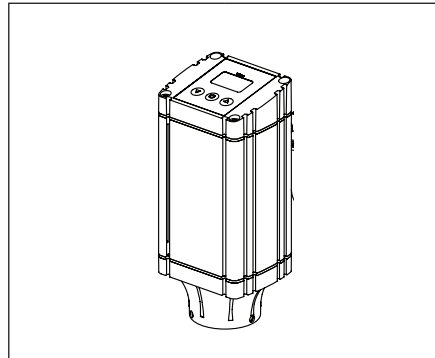

ICAD 1200 with 9.8 ft. (3 m) cables	ICAD 1200 without cable
<b>027H910238</b>	<b>027H9102</b>

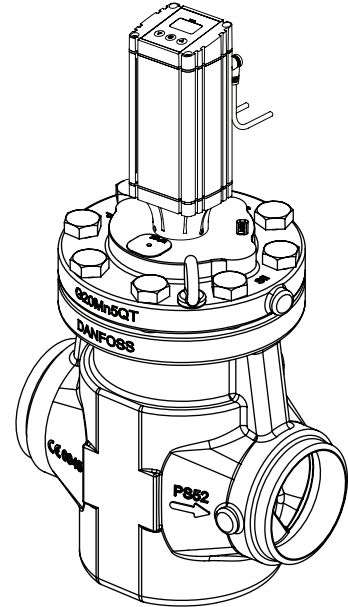

## ICM 100-125-150 Spare Parts

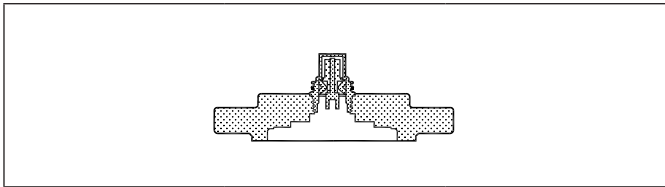

Top covers		
<i>Consist of:</i>	Size	Code number
Top cover complete with magnet coupling and gasket	ICM 100	<b>027H7133</b>
	ICM 125	<b>027H7153</b>
	ICM 150	<b>027H7173</b>

Inspection set A		
<i>Consist of:</i>	Size	Code number
Gasket (pos. 2)	ICM 100	<b>027H7134</b>
O-ring (pos. 3 and pos. 4)	ICM 125	<b>027H7154</b>
	ICM 150	<b>027H7174</b>

Maintenance set B		
<i>Consist of:</i>	Size	Code number
Gasket (pos. 2)	ICM 100	<b>027H7135</b>
O-ring (pos. 3 and pos. 4)	ICM 125	<b>027H7155</b>
Valve plate (pos. 5)	ICM 150	<b>027H7175</b>
Pilot piston (pos. 6)	ICM 150	<b>027H7175</b>

Replacement set C		
<i>Consist of:</i>	Size	Code number
Gasket (pos. 2)	ICM 100	<b>027H7136</b>
Complete insert (pos. 1)	ICM 125	<b>027H7156</b>
Magnet coupling (pos. 7)	ICM 150	<b>027H7176</b>

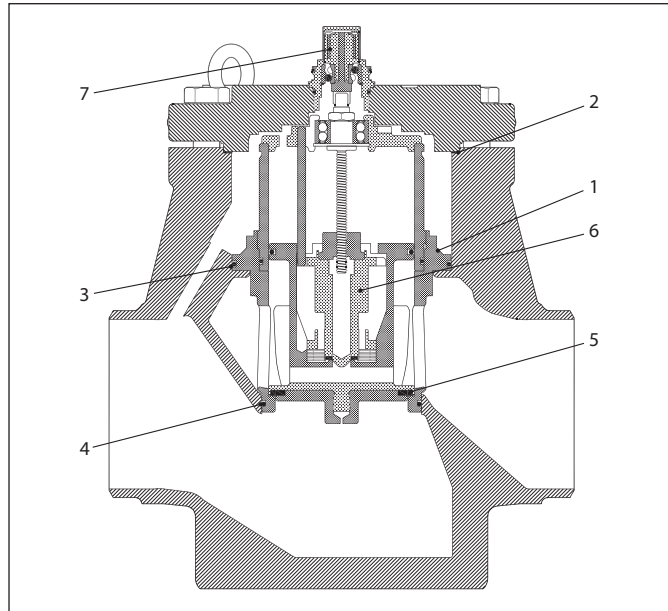

## ICM / ICAD Accessories

### Multi/function tool

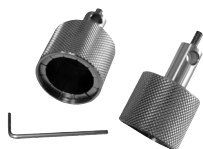

Description	Code Number
For ICM sizes 20, 25, and 32	<b>027H0180</b>
For ICM sizes 40, 50, 65, 100, 125 and 150	<b>027H0181</b>

### Cable for ICAD 600/900/1200

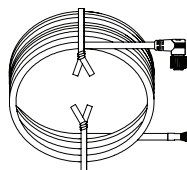

Cable length	Code number
Cable set 1.5 m, female (4.9 ft.)	<b>027H0426</b>
Cable set 3 m, female (9.8 ft.)	<b>027H0438</b>
Cable set 10 m, female (32.8 ft.)	<b>027H0427</b>
Cable set 15 m, female (49 ft.)	<b>027H0435</b>

### Protection cap ICAD 600/900/1200

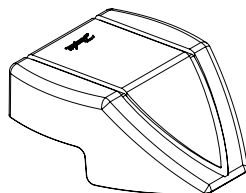

Description	Code number
Protection cap	<b>027H0431</b>

### ICAD-UPS



Description	Code Number
ICAD-UPS	027H0182

### ICM blank top covers including bolts and gasket

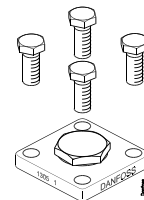

Description	Code Number
ICM 20 blank top cover	<b>027H1174</b>
ICM 25 blank top cover	<b>027H2174</b>
ICM 32 blank top cover	<b>027H3174</b>
ICM 40 blank top cover	<b>027H4174</b>
ICM 50 blank top cover	<b>027H5174</b>
ICM 65 blank top cover	<b>027H6174</b>

### Connectors for ICAD 600/900/1200



Connector type	Code number
Two Female Connectors with screw terminals: - connector for power - connector for control signals	<b>027H0430</b>

## ICM 20 / ICAD 600

### Dimensions and weight including ICAD

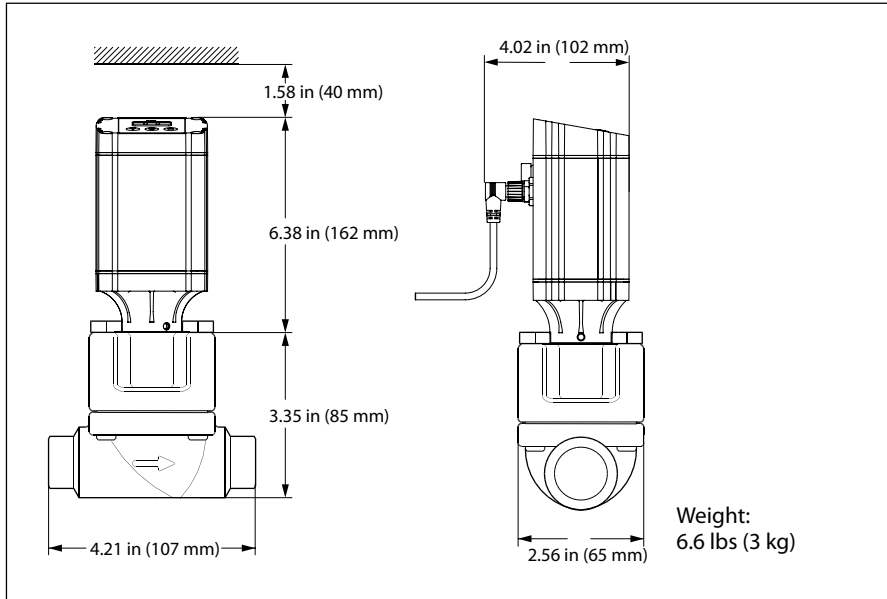

## ICM 25 / ICAD 600

### Dimensions and weight including ICAD

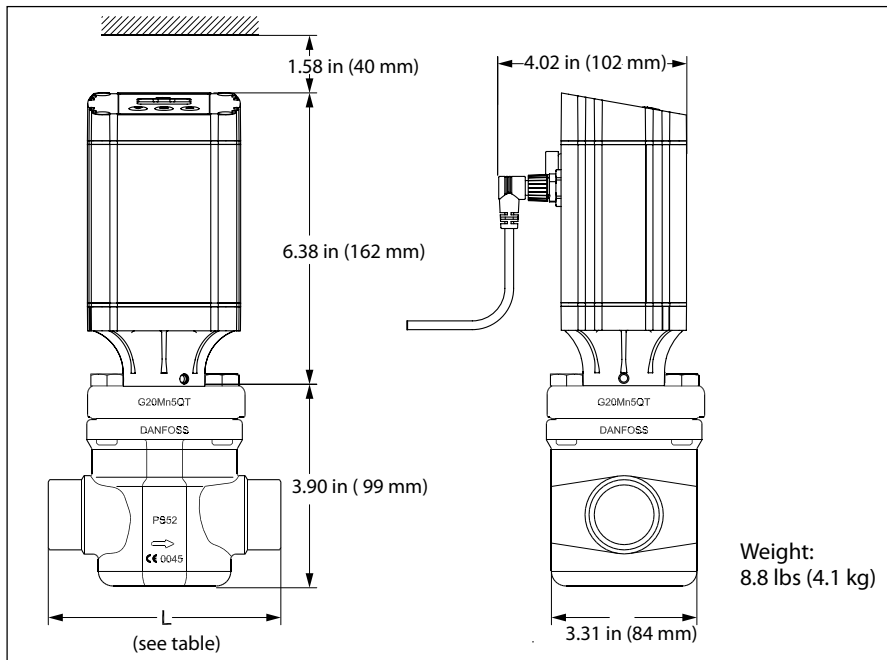

### ICM 25

Connection		L
3/4 to 1 1/4 in. BW	mm	135
	in.	5.31
3/4 in. SOC	mm	135
	in.	5.31
1 in. SOC	mm	148
	in.	5.83
7/8 in. ODS	mm	135
	in.	5.31
1 1/8 to 1 3/8 in. ODS	mm	147
	in.	5.79
3/4 to 1 in. FPT	mm	135
	in.	5.31

BW = Butt-weld ANSI ; SOC = Socket weld ANSI ;  
ODS = Solder ANSI ; FPT = Female Pipe Thread



## ICM 32 / ICAD 600

### Dimensions and weight including ICAD

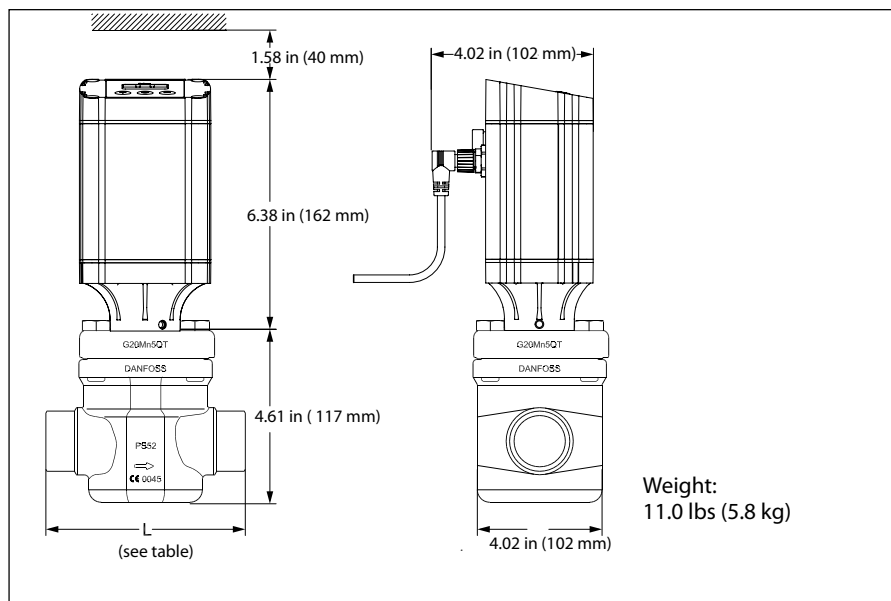

### ICM 32

Connection		L
1 <sup>1</sup> / <sub>4</sub> in. BW	mm	145
	in.	5.71
1 <sup>1</sup> / <sub>2</sub> in. BW	mm	145
	in.	5.71
1 <sup>1</sup> / <sub>4</sub> in. SOC	mm	147
	in.	5.79
1 <sup>3</sup> / <sub>8</sub> in. ODS	mm	148
	in.	5.83
1 <sup>5</sup> / <sub>8</sub> in. ODS	mm	148
	in.	5.83

BW = Butt-weld ANSI ; SOC = Socket weld ANSI ;  
ODS = Solder ANSI

## ICM 40 / ICAD 900 / ICAD 1200

### Dimensions and weight including ICAD

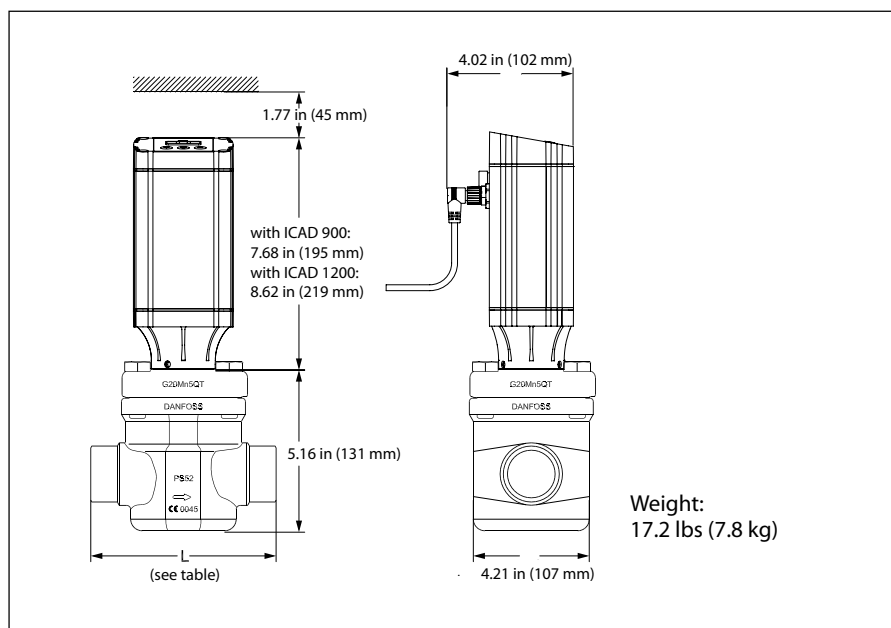

### ICM 40

Connection		L
1 <sup>1</sup> / <sub>2</sub> in. BW	mm	160
	in.	6.30
2 in. BW	mm	180
	in.	7.09
1 <sup>1</sup> / <sub>2</sub> in. SOC	mm	180
	in.	7.09
1 <sup>5</sup> / <sub>8</sub> in. ODS	mm	180
	in.	7.09

BW = Butt-weld ANSI ; SOC = Socket weld ANSI ;  
ODS = Solder ANSI

## ICM 50 / ICAD 900 / ICAD 1200

### Dimensions and weight including ICAD

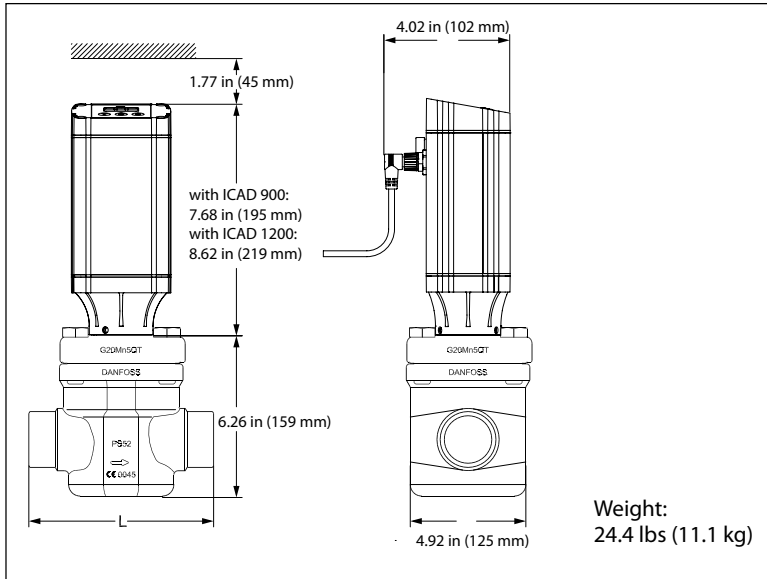

### ICM 50

Connection		L
2 in. BW	mm	200
	in.	7.87
2½ in. BW	mm	210
	in.	8.27
2 in. SOC	mm	216
	in.	8.50
2⅞ in. ODS	mm	216
	in.	8.50

BW = Butt-weld ANSI ; SOC = Socket weld ANSI ; ODS = Solder ANSI

## ICM 65 / ICAD 900 / ICAD 1200

### Dimensions and weight including ICAD

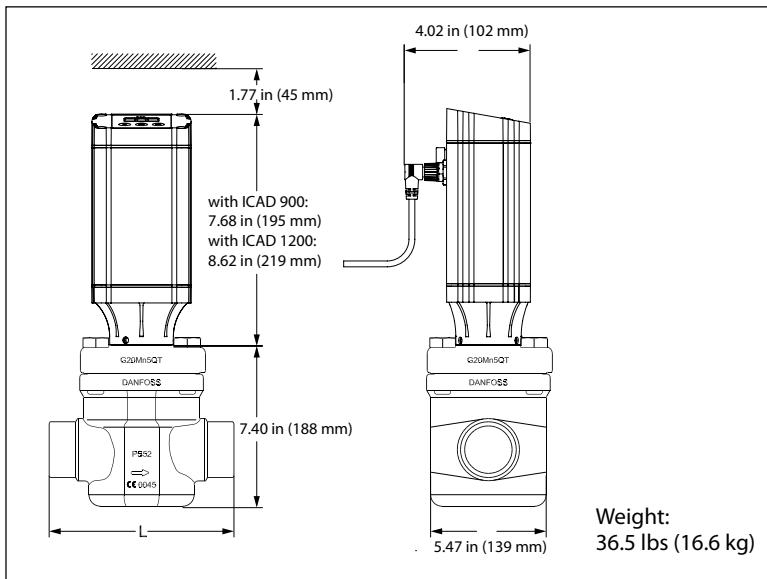

### ICM 65

Connection		L
2½ in. BW	mm	230
	in.	9.06
3 in. BW	mm	245
	in.	9.65
2½ in. SOC	mm	230
	in.	9.06
2⅞ in. ODS	mm	245
	in.	9.65

BW = Butt-weld ANSI ; SOC = Socket weld ANSI ; ODS = Solder ANSI

## ICM 100, 125 and 150 with ICAD motor

### Dimensions and weight including ICAD

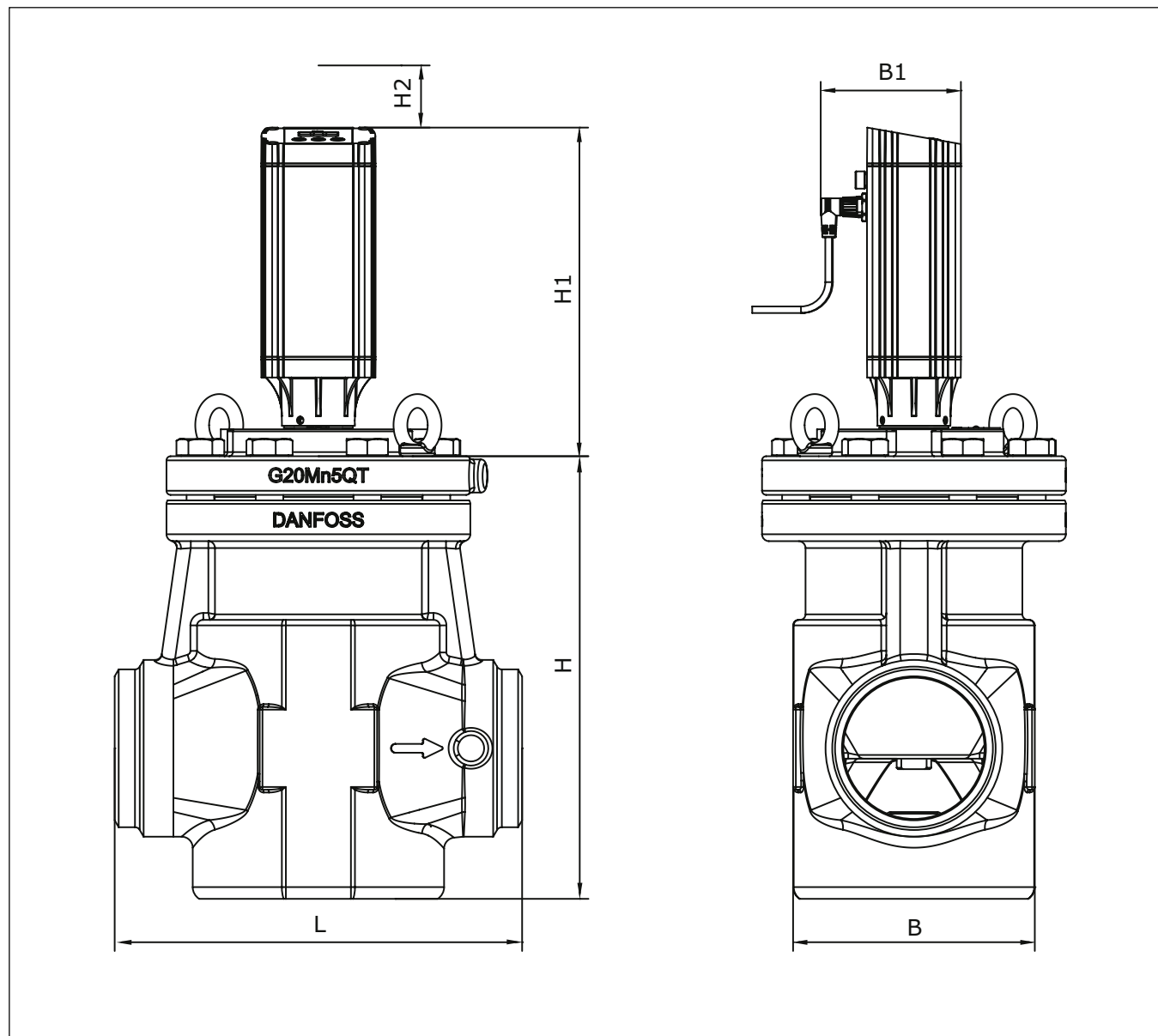

ICM size		H	H <sub>1</sub>	H <sub>2</sub>	L	B	B <sub>1</sub>	Weight ICM incl. ICAD
ICM 100, 4 in.	mm	321	238	45	295	175	102	44 kg.
	in.	12.64	9.37	1.77	11.61	6.89	4.02	97 lb.
ICM 125, 5 in.	mm	365	238	45	350	215	102	55 kg
	in.	14.37	9.37	1.77	13.78	8.47	4.02	121 lb.
ICM 150, 6 in.	mm	443	238	45	445	255	102	95 kg
	in.	17.77	9.37	1.77	17.52	10.04	4.02	209 lb.

BW = Butt-weld ANSI

**Motor valves, type ICM 20-150 and actuators type ICAD 600, 900 and 1200**

**Connections**

BW: Butt-weld ANSI (B 36.10)

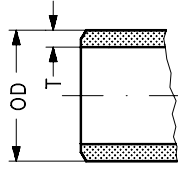

Size mm	Size in.	OD mm	T mm	OD in.	T in.	Schedule	
(20)	3/4	26.9	4.0	1.059	0.158	80	
(25)	1	33.7	4.6	1.327	0.181	80	
(32)	1 1/4	42.4	4.9	1.669	0.193	80	
(40)	1 1/2	48.3	5.1	1.902	0.201	80	
(50)	2	60.3	3.9	2.37	0.15	40	
(65)	2 1/2	73.0	5.2	2.87	0.20	40	
(80)	3	88.9	5.5	3.50	0.22	40	
(100)	4	114.3	6	4.5	0.24		
(125)	5	140.7	6.5	5.5	0.26		
(150)	6	168.3	7.1	6.6	0.28		

SOC:  
Socket welding ANSI (B 16.11)

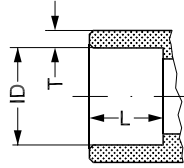

Size mm	Size in.	ID mm	T mm	ID in.	T in.	L mm	L in.
(20)	3/4	27.2	4.6	1.071	0.181	13	0.51
(25)	1	33.9	7.2	1.335	0.284	13	0.51
(32)	1 1/4	42.7	6.1	1.743	0.240	13	0.51
(40)	1 1/2	48.8	6.6	1.921	0.260	13	0.51
(50)	2	61.2	6.2	2.41	0.24	16	0.63
(65)	2 1/2	74	8.8	2.91	0.344	16	0.63

ODS: Soldering (ANSI B 16.22)

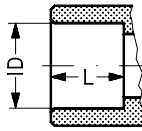

	Size in.		ID in.		L in.
	5/8		0.625		0.591
	7/8		0.875		0.650
	1 1/8		1.125		1.024
	1 3/8		1.375		0.984
	1 5/8		1.625		1.102
	2 1/8		2.125		1.300
	2 5/8		2.625		1.300

FPT:  
Female pipe thread,  
(ANSI/ASME B 1.20.1)

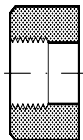

Size mm	Size in.	Inside pipe thread		
(20)	3/4	(3/4 x 14 NPT)		
(25)	1	(1 x 11.5 NPT)		
(32)	1 1/4	(1 1/4 x 11.5 NPT)		