

MAKING MODERN LIVING POSSIBLE



Catalogue

Optyma Plus™ with scroll or reciprocating compressors

R404A / R507, R134a, R407C



www.danfoss.com

OPTYMA PLUS™

DANFOSS CONDENSING UNIT

Optyma Plus™ R404A/R507 LBP/MBP



Cold Room

The refrigerants R404A and R507 are used very widely in refrigeration. A major reason for their popularity is that they are highly flexible. For instance, applications in the standard refrigeration range are just as common as conventional freeze use with R404A or R507. For example, both refrigerants are used for dairy product refrigeration, whether for open storage of such foods or for storage of packaged goods. An example of a freeze application is the storage of frozen food and ice cream.

Optyma Plus™ R134a MBP



Bottle coolers

The refrigerant R134a is often underestimated as far as energy is concerned and is particularly good for medium and high evaporating temperatures. For instance, this refrigerant is popular for bottle coolers and air dryers.

This refrigerant is also standard for refrigerated display cabinets in restaurants and bars. However, conventional standard refrigeration applications for -10°C evaporation in supermarkets are also normally designed for R134a.

So this refrigerant offers a serious alternative to the medium and high temperature applications of R404A and R507.

Optyma Plus™ R407C MBP



Air conditioning systems for butchers, for example

As a successor to the “air conditioning refrigerant” R22, R407C’s main strengths clearly lie in the area of air conditioning. For instance, HVAC comfort air conditioning systems are commonly equipped with a coil and corresponding condensing unit for R407C. This refrigerant can be found everywhere in this area. Nevertheless, we should not forget that there is a wide variety of possible standard refrigeration applications if one is familiar with the characteristics of this refrigerant (key phrase “marked temperature glide”).

In designing our Optyma Plus™ range we integrate your requirements in order to satisfy your needs and expectations of refrigeration solution. Optyma Plus™ combines our best engineering skills and design knowledge to create a fully factory-built condensing unit ready for quick installation and quiet operation.

Optyma Plus™ is a unique integral Danfoss condensing unit built around Danfoss components.

Optyma Plus™ with reciprocating or scroll technology offers what fits best to your application.

As standard we supply the compressor, fan speed control, filter drier, shut off valve, pressure switch, magnetic contactor, sight glass, main switch and compressor protection all within robust weather proof housing. A perfect cooling solution for typical food retail, petrol forecourt sites, cold room and freezer applications.

All units are fully wired and factory tested. Installation is effortlessly simple: just mount the unit, connect to controller, braze two pipe-joints to connect to evaporator circuit, charge the system and switch on the power, and the cooling process is up and running.

Optyma Plus™ can be located anywhere. Acoustic insulation and fan speed reduction during low capacity operation periods makes the operation of Optyma Plus™ so smooth and quiet that it will not disturb the peace in your local environment.

Danfoss Optyma Plus™ condensing units meet Energy related Product (ErP) directive thanks to high efficiency fan motors.

* Products for higher ambient temperatures, please contact your local Danfoss representative.



Optyma Plus™ with reciprocating compressors

Installer benefits	End-user benefits	Product advantages
<ul style="list-style-type: none"> + An integrated Danfoss design + Easy maintenance: just remove the panels and you have easy access to the components + Outstanding performance even in the toughest applications + A minimum size footprint enabling installation in small spaces without compromising the units' performance or service accessibility + Common Danfoss components all stocked locally by wholesalers + Sightglass visible from outside + Full compatible to OPTYMA controller * + Plug & Play installation <p>* refer to separate datasheet</p>	<ul style="list-style-type: none"> + Low noise operation + Modern practical design with a neutral colour to fit in with its surroundings + Strong weather resistant housing with lasting durability even in the harshest environments + Reliable high ambient operation and proven reliability in the most demanding applications + Energy saving benefits with fan speed control and selection of energy efficient components 	<ul style="list-style-type: none"> + Energy efficient + Low energy consumption + Fully weatherproof housing made from epoxy powder coated steel + Electrical box : IP54 + Low noise level + Small dimensions + One range with 2 compressor technologies + Common Danfoss stocked components + Multi-refrigerant capability on most of the units + One compressor on high capacity moduls + Packaging is optimised for stacking + Fully synchronized and factory tested

Test conditions	Unit	Code	Compressor	Amb. temp. °C	Cooling capacity range in (W) at evaporating temperature (°C)								Power consumption (W) at -25°C evap. temp.	
					-45°C	-40°C	-35°C	-30°C	-25°C	-20°C	-15°C	-10°C		
	SH 10K	OP-LPHC018SCP00G	114X3108	SC18CLX	27	220	330	460	620	810	1040	1300	1620	730
					32	180	270	390	540	720	930	1170	1470	
					38	120	210	320	450	600	790	1020	1280	
					43			250	370	510	680			
		OP-LPHC026GSP00G	114X3116	GS26CLX	27	310	470	670	910	1200	1550	1960	2430	960
					32	240	390	570	790	1050	1370	1750	2190	
					38	170	300	450	650	880	1160	1500	1900	
					43			360	530	740	990			
		OP-LPHC048NTP00G	114X3224	NTZ048	27	450	700	1050	1450	1900	2400	2900	3500	1450
					32	350	600	900	1250	1650	2100	2600	3150	
					38	250	450	750	1050	1400	1800	2250	2700	
					43		350	600	850	1200	1550			
	OP-LPHC048NTP00E	114X3232	NTZ048	27	450	750	1050	1450	1900	2350	2850	3450	1450	
				32	400	650	950	1300	1650	2100	2550	3050		
				38	300	500	750	1050	1400	1800	2200	2650		
				43		400	650	900	1200	1550				
	OP-LPHC068NTP00G	114X3240	NTZ068	27	950	1300	1750	2300	2950	3650	4450	5300	2200	
				32	850	1200	1600	2100	2650	3300	4000	4800		
				38	700	1000	1350	1800	2300	2850	3500	4150		
				43		850	1200	1550	2000	2500				
	OP-LPHC068NTP00E	114X3248	NTZ068	27	950	1350	1850	2400	3050	3800	4600	5450	2150	
				32	800	1150	1600	2150	2700	3400	4100	4900		
				38	600	950	1350	1800	2350	2950	3600	4300		
				43		800	1150	1550	2050	2550				
OP-LPHC096NTP00E	114X3356	NTZ096	27	1100	1650	2300	3100	4100	5250	6650	8200	2700		
			32		1400	2000	2750	3650	4750	6000	7450			
			38		1150	1650	2300	3150	4100	5250	6550			
			43		900	1350	1950	2700	3550					
OP-LPHC136NTP00E	114X3364	NTZ136	27	1750	2500	3400	4500	5750	7200	8850	10650	4250		
			32		2200	3000	4000	5150	6500	8000	9650			
			38		1800	2550	3400	4450	5650	6950	8450			
			43		1450	2150	2950	3850	4900					
	SH 10K	OP-LPHC271NTP00E	114X3480	NTZ271	27	3750	5300	7200	9500	12100	15100	18400	22050	8500
					32	3200	4700	6450	8550	10950	13650	16700	20000	
					38	2600	3900	5500	7350	9450	11900	14600	17550	
					43		3250	4650	6350	8250	10400			

Test condition
EN13215
 Ambient temperature

 SH 10K
 32°C

Electrical code
E: Compressor 400 V/3 phase/50 Hz, fan 230 V/1 phase/50 Hz
G: Compressor 230 V/1 phase/50 Hz, fan 230 V/1 phase/50 Hz

 Subcooling within the limits of the condensing unit
 LBP measured according to EN 13215 @-25C suction, +32C ambient, SH 10K

Power consumption referred at 32°C ambient temperature

Type	Condenser coil			Condenser fan	Receiver volume (L)	Dimensions (mm)				Connection (inch)		Sound power level dB(A)	Sound pressure level 10 m dB(A)	Weight Gross/Net (kg)
	Type	Airflow (m³/h)	Int. volume (L)	Fan blade (mm)		Fig.	Height H	Width W	Depth D	Suction line	Liquid line			
OP-LPHC018 SCP00G	A6	1500	1.6	1×356	1.2 - 1.4	1	652	906	430	12"	38"	61	30	96/64
OP-LPHC026 GSP00G	A6	1500	1.6	1×356	1.2 - 1.4	1	652	906	430	58"	38"	61	30	102/76
OP-LPHC048 NTP00G	C6	3000	1.1	1×406	4.2 - 4.6	2	760	1053	480	58"	38"	72	41	116/82
OP-LPHC048 NTP00E	C6	3000	1.1	1×406	4.2 - 4.6	2	760	1053	480	58"	38"	72	41	116/82
OP-LPHC068 NTP00G	D6	2600	2.2	1×406	4.2 - 4.6	2	760	1053	480	58"	38"	71	39	118/84
OP-LPHC068 NTP00E	D6	2600	2.2	1×406	4.2 - 4.6	2	760	1053	480	58"	38"	71	39	118/84
OP-LPHC096 NTP00E	F6	6100	3.4	1×609	7.0 - 7.6	3	975	1406	550	78"	38"	73	42	161/115
OP-LPHC136 NTP00E	F6	6100	3.4	1×609	7.0 - 7.6	3	975	1406	550	1"18	1/2"	73	72	161/115
OP-LPHC271 NTP00E	J6	12200	6.9	2×609	13.6 - 14.0	4	1794	1420	650	1"38	3/4"	78	47	329/275

Sound measurement done in accordance with ISO 3743-1 and ISO 3744.
LBP measured according to EN 13215 @ -25°C suction, +32°C ambient, SH 10 K

Test conditions	Unit	Code	Compressor	Amb. temp. °C	Cooling capacity range in (W) at evaporating temperature (°C)						Power consumption (W) at evap. temp. -10°C		
					-20°C	-15°C	-10°C	-5°C	0°C	+5°C		+10°C	
SH =10K	OP-MPHC010 SCP00G	114X4100	SC10MLX	27	570	730	920	1140	1410	1710	570		
				32	510	650	820	1030	1270	1550			
				38	430	560	710	890	1110	1360			
				43		480	610	780	970				
	OP-MPHC012SCP00G	114X4103	SC12MLX	SC12MLX	27	700	890	1110	1380	1690	2060	660	
					32	620	790	1000	1240	1530	1870		
					38	530	680	860	1080	1340	1640		
					43	450	590	750	940	1170	1440		
	OP-MPHC018 SCP00G	114X4108	SC18MLX	SC18MLX	27	1010	1280	1590	1970	2410	2920	910	
					32	900	1140	1440	1790	2200	2670		
					38	770	990	1250	1560	1930	2370		
					43		860	1090	1370	1710			
	OP-MPZC030MTP00G	114X4216	MTZ018	MTZ018	27	1300	1750	2300	2850	3500	4150	4850	1300
					32	1150	1600	2050	2600	3150	3750	4400	
					38	1000	1350	1800	2250	2750	3300	3900	
					43	850	1200	1550	1950	2400			
	OP-MPZC030MTP00E	114X4224	MTZ018	MTZ018	27	1300	1750	2300	2850	3500	4150	4850	1300
					32	1150	1600	2050	2600	3150	3750	4400	
					38	1000	1350	1800	2250	2750	3300	3900	
					43	850	1200	1550	1950	2400			
OP-MPHC026GSP00G	114X4215	GS26MLX	GS26MLX	27		1990	2500	3100	3800	4610	1300		
				32		1780	2250	2800	3450	4200			
				38		1530	1950	2450	3030	3710			
				43		1330	1710	2160	2680	3300			
OP-MPHC034GSP00G	114X4228	GS34MLX	GS34MLX	27		2620	3240	3960	4800	5770	1800		
				32		2360	2940	3610	4400	5300			
				38		2040	2560	3170	3880	4700			
				43		1780	2250	2790	3430	4180			
OP-MPZC048MTP00G	114X4232	MTZ028	MTZ028	27	2500	3250	4050	4950	5950	7050	8150	2050	
				32	2200	2900	3650	4500	5400	6400	7450		
				38	1900	2500	3150	3950	4750	5650	6600		
				43	1600	2150	2750	3450	4200				
OP-MPZC048MTP00E	114X4240	MTZ028	MTZ028	27	2500	3250	4050	4950	5950	7050	8150	2050	
				32	2200	2900	3650	4500	5400	6400	7450		
				38	1900	2500	3150	3950	4750	5650	6600		
				43	1600	2150	2750	3450	4200				
OP-MPZC060MTP00G	114X4248	MTZ036	MTZ036	27	3300	4150	5100	6100	7150	8250	9400	2700	
				32	2950	3750	4600	5500	6500	7500	8550		
				38	2550	3250	4000	4800	5650	6550	7500		
				43	2200	2850	3500	4250	5000				
OP-MPZC060MTP00E	114X4256	MTZ036	MTZ036	27	3300	4150	5100	6100	7150	8250	9400	2700	
				32	2950	3750	4600	5500	6500	7500	8550		
				38	2550	3250	4000	4800	5650	6550	7500		
				43	2200	2850	3500	4250	5000				
OP-MPZC086MTP00E	114X4364	MTZ050	MTZ050	27	4750	6100	7650	9400	11300	13400	15600	3350	
				32	4250	5450	6900	8500	10250	12150	14250		
				38	3650	4750	6000	7400	9000	10750	12600		
				43	3150	4150	5250	6550	8000				
OP-MPZC108MTP00E	114X4372	MTZ064	MTZ064	27	5800	7400	9200	11200	13400	15750	18300	4400	
				32	5200	6650	8300	10150	12150	14350	16700		
				38	4450	5750	7250	8900	10700	12700	14800		
				43	3850	5000	6350	7850	9500				
OP-MPZC136MTP00E	114X4380	MTZ080	MTZ080	27	7600	9500	11600	13900	16350	19000	21750	5800	
				32	6850	8600	10500	12650	14900	17350	19850		
				38	5950	7500	9200	11100	13150	15300	17600		
				43	5200	6600	8150	9850	11700				
OP-MPUC125MLP00E	114X4413	MLZ058	MLZ058	27	9850	12050	14650	17550	20800	24200	27800	6500	
				32	8850	10900	13300	16050	19050	22300	25650		
				38	7550	9400	11600	14100	16900	19850	22950		
				43	6400	8100	10150	12450	15000	17750	20650		
OP-MPZC171MTP00E	114X4488	MTZ100	MTZ100	27	9150	11800	14800	18200	21900	25900	30150	7400	
				32	8300	10700	13450	16550	19950	23600	27500		
				38	7200	9350	11850	14600	17600	20850	24350		
				43	6300	8250	10450	12900	15650				
OP-MPZC215MTP00E	114X4496	MTZ125	MTZ125	27	11700	14750	18200	22050	26250	30800	35550	9200	
				32	10450	13250	16450	19950	23850	28000	32450		
				38	9000	11500	14350	17500	21000	24750	28750		
				43	7850	10100	12650	15500	18650				
OP-MPUC162MLP00E	114X4433	MLZ076	MLZ076	27	12950	15650	18600	21850	25450	29450	33800	8500	
				32	11850	14250	16900	19850	23100	26750	30750		
				38	10450	12500	14750	17300	20150	23350	26950		
				43	9300	11000	12900	15100	17550	20400	23650		

Test condition EN13215

SH 10K
32°C

Ambient temperature
Subcooling within the limits of the condensing unit
MBP measured according to EN 13215 @-10C suction, +32C ambient, SH 10K

Electrical code

G: Compressor 230 V/1 phase/50 Hz, fan 230 V/1 phase/50 Hz
E: Compressor 400 V/3 phase/50 Hz, fan 230 V/1 phase/50 Hz

Power consumption referred at 32°C ambient temperature

Type	Condenser coil			Condenser-fan Fan blade Ø (mm)	Receiver volume (L)	Dimensions (mm)				Connection (Inch)		Sound power level dB(A)	Sound pressure level 10 m dB(A)	Weight Gross/Net (kg)
	Type	Airflow (m ³ /h)	Int. volume (L)			Fig.	Height H	Width W	Depth D	Suction line	Liquid line			
OP-MPHC010 SCP00G	A6	1500	1.6	1×356	1.2 - 1.4	1	652	906	430	3/8"	3/8"	61	30	96/64
OP-MPHC012 SCP00G	A6	1500	1.6	1×356	1.2 - 1.4	1	652	906	430	3/8"	3/8"	61	30	97/65
OP-MPHC018 SCP00G	A6	1500	1.6	1×356	1.2 - 1.4	1	652	906	430	3/8"	3/8"	61	30	96/64
OP-MPZC030 MTP00G	C6	3000	1.1	1×406	4.2 - 4.6	2	760	1053	480	5/8"	3/8"	72	41	116/83
OP-MPZC030 MTP00E	C6	3000	1.1	1×406	4.2 - 4.6	2	760	1053	480	5/8"	3/8"	72	41	116/83
OP-MPHC026 GSP00G	D6	2600	2.2	1×406	4.2 - 4.6	2	760	153	480	5/8"	3/8"	67	36	113/81
OP-MPHC034 GSP00G	D6	2600	2.2	1×406	4.2 - 4.6	2	760	1053	480	5/8"	3/8"	67	36	114/82
OP-MPZC048 MTP00G	D6	2600	2.2	1×406	4.2 - 4.6	2	760	1053	480	5/8"	3/8"	71	39	120/86
OP-MPZC048 MTP00E	D6	2600	2.2	1×406	4.2 - 4.6	2	760	1053	480	5/8"	3/8"	71	39	120/86
OP-MPZC060 MTP00G	D6	2600	2.2	1×406	4.2 - 4.6	2	760	1053	480	5/8"	3/8"	72	40	125/88
OP-MPZC060 MTP00E	D6	2600	2.2	1×406	4.2 - 4.6	2	760	1053	480	5/8"	3/8"	72	40	125/88
OP-MPZC086 MTP00E	F6	6100	3.4	1×609	7.0 - 7.6	3	975	1406	550	7/8"	5/8"	74	42	163/117
OP-MPZC108 MTP00E	F6	6100	3.4	1×609	7.0 - 7.6	3	975	1406	550	7/8"	5/8"	74	42	163/117
OP-MPZC136 MTP00E	G6	5100	5.2	1×609	7.0 - 7.6	3	975	1406	550	1"1/8	5/8"	76	45	168/122
OP-MPUC125 MLP00E	J6	12200	6.9	2×609	13.6 - 14.0	4	1794	1420	650	1"1/8	3/4"	78	47	312/242
OP-MPZC171 MTP00E	J6	12200	6.9	2×609	13.6 - 14.0	4	1794	1420	650	1"3/8	5/8"	78	47	327/271
OP-MPZC215 MTP00E	J6	12200	6.9	2×609	13.6 - 14.0	4	1794	1420	650	1"3/8	3/4"	78	47	329/275
OP-MPUC162 MLP00E	J6	12200	6.9	2×609	13.6 - 14.0	4	1794	1420	650	1"3/8	3/4"	78	47	313/243

Sound measurement done in accordance with ISO 3743-1 and ISO 3744.
LBP measured according to EN 13215 @ -10°C suction, +32°C ambient, SH 10 K

Test conditions	Unit	Code	Compressor	Amb. temp. °C	Cooling capacity range in (W) at evaporating temperature (°C)								Power consumption (W) at evap. temp. -10°C
					-15°C	-10°C	-5°C	0°C	+5°C	+10°C	+15°C	+20°C	
SH = 10K	OP-MPZC030MTP00G	114X4216	MTZ018	27	950	1350	1850	2350	2900	3550	4250	4950	750
				32	900	1250	1650	2150	2700	3250	3900	4600	
				38	750	1100	1450	1900	2400	2950	3500	4150	
				43	650	950	1300	1700	2150	2650			
	OP-MPZC030MTP00E	114X4224	MTZ018	27	950	1350	1850	2350	2900	3550	4250	4950	750
				32	900	1250	1650	2150	2700	3250	3900	4600	
				38	750	1100	1450	1900	2400	2950	3500	4150	
				43	650	950	1300	1700	2150	2650			
	OP-MPGC034GSP00G	114X4112	GS34MFX	27	1420	1800	2260	2800	3430				950
				32	1310	1670	2100	2620	3220				
				38	1170	1510	1920	2400	2960				
				43	1060	1380	1760	2210	2740				
	OP-MPZC048MTP00G	114X4232	MTZ028	27	1500	2100	2800	3650	4600	5650	6900	8200	1050
				32	1500	2000	2600	3400	4250	5300	6400	7700	
				38	1300	1800	2350	3050	3900	4800	5850	7000	
				43	1200	1600	2150	2800	3550	4400			
	OP-MPZC048MTP00E	114X4240	MTZ028	27	1500	2100	2800	3650	4600	5650	6900	8200	1050
				32	1500	2000	2600	3400	4250	5300	6400	7700	
				38	1300	1800	2350	3050	3900	4800	5850	7000	
				43	1200	1600	2150	2800	3550	4400			
	OP-MPZC060MTP00G	114X4248	MTZ036	27	2450	3200	4000	4950	6050	7250	8500	9900	1500
				32	2300	2950	3750	4650	5650	6800	8000	9300	
				38	2050	2700	3450	4250	5200	6200	7350	8550	
				43	1900	2500	3150	3900	4800	5750			
OP-MPZC060MTP00E	114X4256	MTZ036	27	2450	3200	4000	4950	6050	7250	8500	9900	1500	
			32	2300	2950	3750	4650	5650	6800	8000	9300		
			38	2050	2700	3450	4250	5200	6200	7350	8550		
			43	1900	2500	3150	3900	4800	5750				
OP-MPZC086MTP00E	114X4364	MTZ050	27	3000	4150	5600	7250	9000	11050	13250	15700	1950	
			32	2950	3950	5200	6650	8300	10200	12300	14650		
			38	2550	3500	4650	5950	7500	9250	11200	13400		
			43	2250	3150	4200	5450	6900	8500				
OP-MPZC108MTP00E	114X4372	MTZ064	27	3450	4900	6700	8550	10700	13100	15700	18500	2300	
			32	3300	4600	6150	7950	9950	12200	14700	17350		
			38	2900	4100	5550	7200	9100	11200	13500	15950		
			43	2550	3700	5050	6600	8400	10350				
OP-MPZC136MTP00E	114X4380	MTZ080	27	5050	6800	8750	11000	13600	16450	19600	23050	3050	
			32	4800	6350	8150	10300	12700	15450	18450	21700		
			38	4250	5700	7400	9400	11650	14200	17000	20050		
			43	3850	5200	6800	8650	10750	13150				
OP-MPZC171MTP00E	114X4488	MTZ100	27	5850	8000	10650	13800	17150	21000	25350	30100	4300	
			32	5750	7700	10050	12800	16000	19650	23750	28250		
			38	5000	6850	9050	11600	14600	18000	21800	26000		
			43	4500	6200	8250	10650	13450	16600				
OP-MPUC125MLP00E	114X4413	MLZ058	27	6950	8700	10750	13100	15700	18700	22000		3950	
			32	6500	8200	10150	12400	14950	17800	20950			
			38	6000	7600	9450	11600	14000	16650	19700			
			43	5550	7100	8850	10850	13150	15700	18600			
OP-MPZC215MTP00E	114X4496	MTZ125	27	7550	10150	13350	16750	20600	24950	29750	35000	4900	
			32	7200	9550	12300	15500	19200	23300	27850	32850		
			38	6250	8450	11050	14050	17450	21300	25550	30150		
			43	5550	7600	10050	12850	16000	19600				
OP-MPUC162MLP00E	114X4433	MLZ076	27	8850	11050	13650	16600	19900	23600	27650		5000	
			32	8300	10450	12900	15700	18900	22450	26350			
			38	7650	9650	12000	14650	17650	21000	24700			
			43	7150	9000	11200	13700	16550	19750	23300			

Test conditions

EN13215 SH10K
Ambient temperature 32°C

Electrical code

E: Compressor 400 V/3 phase/50 Hz, fan 230 V/1 phase/50 Hz
G: Compressor 230 V/1 phase/50 Hz, fan 230 V/1 phase/50 Hz

Subcooling within the limits of the condensing unit
MBP measured according to EN 13215 @-10C suction, +32C ambient, SH 10K

Power consumption referred at 32°C ambient temperature

Type	Condenser coil			Condenser fan	Receiver volume (L)	Fig.	Dimensions (mm)			Connection (Inch)		Sound power level dB(A)	Sound pressure level 10 m dB(A)	Weight Gross/Net (kg)
	Type	Airflow (m3/h)	Int. volume (L)	Fan blade Ø (mm)			Height H	Width W	Depth D	Suction line	Liquid line			
OP-MPZC030 MTP00G	C6	3000	1.1	1×406	4.2 - 4.6	2	760	1053	480	58"	38"	72	41	116/83
OP-MPZC030 MTP00E	C6	3000	1.1	1×406	4.2 - 4.6	2	760	1053	480	58"	38"	72	41	116/83
OP-MPGC034 GSP00G	A6	1500	1.6	1×356	1.2 - 1.4	1	652	906	430	1/2"	3/8"	63	32	102/76
OP-MPZC048 MTP00G	D6	2600	2.2	1×406	4.2 - 4.6	2	760	1053	480	58"	38"	71	39	120/86
OP-MPZC048 MTP00E	D6	2600	2.2	1×406	4.2 - 4.6	2	760	1053	480	58"	38"	71	39	120/86
OP-MPZC060 MTP00G	D6	2600	2.2	1×406	4.2 - 4.6	2	760	1053	480	3/4"	3/8"	72	40	125/88
OP-MPZC060 MTP00E	D6	2600	2.2	1×406	4.2 - 4.6	2	760	1053	480	3/4"	3/8"	72	40	125/88
OP-MPZC086 MTP00E	F6	6100	3.4	1×609	7.0 - 7.6	3	975	1406	550	7/8"	5/8"	74	42	163/117
OP-MPZC108 MTP00E	F6	6100	3.4	1×609	7.0 - 7.6	3	975	1406	550	7/8"	5/8"	74	42	163/117
OP-MPZC136 MTP00E	G6	5100	5.2	1×609	7.0 - 7.6	3	975	1406	550	1"1/8	5/8"	76	45	168/122
OP-MPZC171 MTP00E	J6	12200	6.9	2×609	13.6 - 14.0	4	1794	1420	650	1"3/8	5/8"	78	47	327/271
OP-MPUC125 MLP00E	J6	12 200	6.9	2×609	13.6 - 14.0	4	1794	1420	650	1"1/8	3/4"	78	47	312/242
OP-MPZC215 MTP00E	J6	12200	6.9	2×609	13.6 - 14.0	4	1794	1420	650	1"3/8	3/4"	78	47	329/275
OP-MPUC162 MLP00E	J6	12 200	6.9	2×609	13.6 - 14.0	4	1794	1420	650	1"3/8	3/4"	78	47	313/243

Sound measurement done in accordance with ISO 3743-1 and ISO 3744.
MBP measured according to EN 13215 @ -10°C suction, +32°C ambient, SH 10 K

Test conditions	Unit	Code	Compressor	Amb. temp. °C	Cooling capacity range in (W) at evaporating temperature (°C)						Power consumption (W) at evap. temp. -10°C
					-15°C	-10°C	-5°C	0°C	+5°C	+10°C	
	OP-MPZC030MTP00G	114X4216	MTZ018	27	1400	1900	2500	3150	3850	4600	1050
				32	1300	1750	2300	2900	3550	4250	
				38		1600	2100	2650	3200	3850	
				43			1900	2400			
	OP-MPZC030MTP00E	114X4224	MTZ018	27	1450	1950	2500	3150	3850	4550	1050
				32	1250	1750	2300	2900	3550	4200	
				38		1550	2050	2550	3150	3800	
				43			1800	2300			
	OP-MPZC048MTP00G	114X4232	MTZ028	27	2450	3300	4250	5300	6400	7550	1650
				32	2250	3050	3900	4900	5900	6950	
				38		2700	3500	4400	5300	6300	
				43			3150	3950			
	OP-MPZC048MTP00E	114X4240	MTZ028	27	2550	3350	4300	5300	6400	7600	1600
				32	2250	3050	3950	4900	5950	7050	
				38		2700	3500	4400	5350	6350	
				43			3150	4000			
	OP-MPZC060MTP00G	114X4248	MTZ036	27	3300	4250	5300	6450	7650	8900	2150
				32	3000	3900	4850	5950	7050	8200	
				38		3400	4350	5300	6300	7350	
				43			3850	4750			
	OP-MPZC060MTP00E	114X4256	MTZ036	27	3450	4350	5350	6450	7550	8700	2200
				32	3150	4000	4950	5950	6950	8000	
				38		3600	4450	5350	6250	7250	
				43			4000	4850			
OP-MPZC086MTP00E	114X4364	MTZ050	27	4850	6300	7950	9800	11850	14050	2850	
			32	4450	5750	7300	9050	10950	13000		
			38		5150	6550	8100	9850	11750		
			43			5900	7350				
OP-MPZC108MTP00E	114X4372	MTZ064	27	6100	7800	9700	11850	14150	16700	3550	
			32	5550	7150	8900	10900	13100	15450		
			38		6350	8000	9800	11800	14000		
			43			7250	8900				
OP-MPZC136MTP00E	114X4380	MTZ080	27	7750	9850	12250	14900	17700	20650	4850	
			32	7100	9100	11350	13800	16400	19150		
			38		8150	10200	12450	14850	17350		
			43			9300	11350				
OP-MPZC171MTP00E	114X4488	MTZ100	27	9200	12250	15600	19350	23500	28000	6200	
			32	8400	11150	14300	17800	21700	25900		
			38		9850	12750	15950	19550	23400		
			43			11450	14450				
OP-MPZC215MTP00E	114X4496	MTZ125	27	12600	16000	19800	23950	28500	33350	7750	
			32	11500	14700	18250	22150	26400	30950		
			38		13100	16400	20000	23850	28000		
			43			14850	18150				

Test condition
EN13215

SH 10K
32°C

Electrical code

E: Compressor 400 V/3 phase/50 Hz, fan 230 V/1 phase/50 Hz

G: Compressor 230 V/1 phase/50 Hz, fan 230 V/1 phase/50 Hz

Subcooling within the limits of the condensing unit

MBP measured according to EN 13215 @-10C suction, +32C ambient, SH 10K

Power consumption referred at 32°C ambient temperature

Type	Condenser coil			Condenser fan	Receiver volume (L)	Fig.	Dimensions (mm)			Connection (Inch)		Sound power level dB(A)	Sound pressure level 10 m dB(A)	Weight Gross/Net (kg)
	Type	Airflow (m3/h)	Int. volume (L)	Fan blade Ø (mm)			Height H	Width W	Depth D	Suction line	Liquid line			
OP-MPZC030 MTP00G	C6	3000	1.1	1×406	4.2 - 4.6	2	760	1053	480	58"	38"	72	41	116/83
OP-MPZC030 MTP00E	C6	3000	1.1	1×406	4.2 - 4.6	2	760	1053	480	58"	38"	72	41	116/83
OP-MPZC048 MTP00G	D6	2600	2.2	1×406	4.2 - 4.6	2	760	1053	480	58"	38"	71	39	120/86
OP-MPZC048 MTP00E	D6	2600	2.2	1×406	4.2 - 4.6	2	760	1053	480	58"	38"	71	39	120/86
OP-MPZC060 MTP00G	D6	2600	2.2	1×406	4.2 - 4.6	2	760	1053	480	3/4"	38"	72	40	125/88
OP-MPZC060 MTP00E	D6	2600	2.2	1×406	4.2 - 4.6	2	760	1053	480	3/4"	38"	72	40	125/88
OP-MPZC086 MTP00E	F6	6100	3.4	1×609	7.0 - 7.6	3	975	1406	550	7/8"	58"	74	42	163/117
OP-MPZC108 MTP00E	F6	6100	3.4	1×609	7.0 - 7.6	3	975	1406	550	7/8"	58"	74	42	163/117
OP-MPZC136 MTP00E	G6	5100	5.2	1×609	7.0 - 7.6	3	975	1406	550	1"1/8	58"	76	45	168/122
OP-MPZC171 MTP00E	J6	12200	6.9	2×609	13.6 - 14.0	4	1794	1420	650	1"3/8	58"	78	47	327/271
OP-MPZC215 MTP00E	J6	12200	6.9	2×609	13.6 - 14.0	4	1794	1420	650	1"3/8	3/4"	78	47	329/275

Sound measurement done in accordance with ISO 3743-1 and ISO 3744.
MBP measured according to EN 13215 @ -10°C suction, +32°C ambient, SH 10 K

Electrical characteristics – 230 V, 1 phase, 50 Hz

Unit	Wiring diagram	LRA Compressor (A)	MCC Compressor (A)	Max. continuous power consumption (kW)	Contactor	Code number ① 230 V 50 Hz	Main switch	Code number ①	MCC fan (A)	Fan power (W)
OP-LPHC018	WD1	23.5	5.3	0.98	CI 9 DILM9-01	037H002131 Moeller	CTI25M PKZM0-10	047B3149 Moeller	0.32	1x25
OP-LPHC026	WD2	25.7	5.4	1.36						
OP-LPHC048	WD2	37	11	2.09	CI 12 DILM12-01	037H003131 Moeller	CTI25MB PKZM0-16	047B3157 Moeller	0.47	1x68
OP-LPHC068	WD2	53	17	3.51	CI 15 DILM15-01	037H004931 Moeller	CTI25MB PKZM0-20	047B3158 Moeller		

Electrical characteristics – 400 V, 3 phase, 50 Hz

Unit	Wiring diagram	LRA Compressor (A)	MCC Compressor (A)	Max. continuous power consumption (kW)	Contactor	Code number ① 230 V 50 Hz	Main switch	Code number ①	MCC fan (A)	Fan power (W)
OP-LPHC048	WD3	16	4.8	2.17	CI 6 DILM7-01	037H001531 Moeller	CTI25M PKZM0-6.3	047B3148 Moeller	0.47	1x68
OP-LPHC068	WD3	25	8.4	3.46	CI 9 DILM9-01	037H002131 Moeller	CTI25M PKZM0-16	047B3157 Moeller		
OP-LPHC096	WD3	32	10.1	4.32	CI 12 DILM12-01	037H003131 Moeller	CTI25MB PKZM0-10	047B3149 Moeller	0.96	1x120
OP-LPHC136	WD3	51	14.3	6.65			CTI25MB PKZM0-16	047B3157 Moeller		
OP-LPHC271	WD3	96	27	12,41	CI 30 DILM25-01	037H005531 Moeller	CTI25MB PKZM0-25	047B3159 Moeller	2x0.96	2x120

① Moeller spare parts or individual electrical components are not supplied by Danfoss

Spare parts

Unit	Filter drier		Sight glass		Pressure switch		Suction valve		Liquid valve		Fan Speed controller	
OP-LPHC018	DML82.5s DML083	023Z4568 023Z5040	SGN10s SGN+10s	014-0182 014F0182	KP17 WB	060-539766	GBC12s	009G7052	GBC10s	009G7051	RGE-Z1L4-7DS XGE-4CB1	061H3045 061H3142
OP-LPHC026							GBC16s	009G7053				
OP-LPHC048												
OP-LPHC068							GBC28s	009G7056				
OP-LPHC096	DML162.5s DML163	023Z4576 023Z5043	SGN12s SGN+12s	014-0183 014F0183	GBC35s	009G7057			GBC18s	009G7054		
OP-LPHC136											DML164s DML164	023Z4580 023Z5044
OP-LPHC271	DML166s DML166	023Z4582 023Z5046	SGN19s SGN+19s	014-0185 014F0185								

Spare parts

Unit Platform		Receiver volume (L)				Fan Motor (capacitor included)		Fan Blade		Fan Grill		Fan capacitor (µF)		Handling handle
		A		B										
OP-LPHC018	SC	1.2	118U0003	1.4	118U0023	Fan motor 25 W	118U0016	Blade Ø14"	118U0017	Grill H1	118U0018	1.8	118U0019	118U0013
OP-LPHC026	GS													
OP-LPHC048	NT	4.2	118U0004	4.6	118U0024	Fan motor 68 W	118U3823*	Blade Ø16"	118U0009	Grill H2	118U0011	3.5	118U0014	
OP-LPHC068	NT													
OP-LPHC096	NT	7.0	118U0005	7.6	118U0025	Fan motor 120 W	118U0008	Blade Ø24"	118U0010	Grill H3	118U0012	6.0	118U0015	
OP-LPHC136	NT													
OP-LPHC271	NT	14.0	118U0006	13.6	118U0026					Grill H4				

Note:
 LRA (Locked Rotor Amps) A = Receiver without valve 1) Moeller spare parts or individual electrical components are not supplied by Danfoss
 MCC (Maximum Continuous Current) B = Receiver with valve on top

* fan motor should be replaced by the old one 11/U3478 (75W) for the unit with serial number up to xxxxxCG4812 produced before December 2012.

Electrical characteristics – 230 V, 1 phase, 50 Hz

Unit	Wiring diagram	LRA Compressor (A)	MCC Compressor (A)	Max. continuous power consumption (kW)	Contactor	Code number ① 230 V 50 Hz	Main switch	Code number ①	MCC fan (A)	Fan power (W)
OP-MPHC010	WD1	18.4	4.8	0.65	CI 6 DILM7-01	037H001531 Moeller	CTI25M PKZM0-6,3	047B3148 Moeller	0.32	1×25
OP-MPHC012	WD1	23.4	5.7	0.78						
OP-MPHC018	WD2	23.4	6.1	1.13	CI 9 DILM9-01	037H002131 Moeller	CTI25M PkZM0-10	047B3149 Moeller	0.47	1×68
OP-MPHC026	WD2	34.6	8.5	1.58						
OP-MPZC030	WD2	40	10	1.82						
OP-MPHC034	WD2	45.7	12.6	2.32	CI15 DILM15-01	037H004931 Moeller	CTI25MB PKZM0-16	047B3157 Moeller	0.47	1×68
OP-MPZC048	WD2	51	20	3.11	CI 15 DILM15-01	037H004931 Moeller	CTI25MB PKZM0-20	047B3158 Moeller		
OP-MPZC060	WD2	60	22	4.10	CI 20 DILM25-01	037H004531 Moeller	CTI25MB PKZM0-25	047B3159 Moeller		

Electrical characteristics – 400 V, 3 phase, 50 Hz

Unit	Wiring diagram	LRA Compressor (A)	MCC Compressor (A)	Max. continuous power consumption (kW)	Contactor	Code number ① 230 V 50 Hz	Main switch	Code number ①	MCC fan (A)	Fan power (W)
OP-MPZC030	WD3	20	5	1.82	CI 6 DILM7-01	037H001531 Moeller	CTI25M PKZM0-6,3	047B3148 Moeller	0.47	1×68
OP-MPZC048	WD3	23	7.5	3.11	CI 9 DILM9-01	037H002131 Moeller	CTI25M PKZM0-10	047B3149 Moeller		
OP-MPZC060	WD3	30	9.0	4.10			CI 12 DILM12-01	037H003131 Moeller	CTI25MB PKZM0-16	047B3157 Moeller
OP-MPZC086	WD3	48.5	11.5	4.89						
OP-MPZC108	WD3	64	15	7.09	CI 16 DILM15-01	037H004131 Moeller				
OP-MPZC136	WD3	80	19	8.68						
OP-MPZC171	WD3	90	22	10.10	CI 25 DILM25-01	037H005131 Moeller	CTI25MB PKZM0-25	047B3159 Moeller	2×0.96	2×120
OP-MPZC215	WD3	105	27	13.20	CI 30 DILM32-01	037H005531 Moeller				
OP-MPUC125	WD3	95	20.0	11.1	DILM17-01	Moeller	PKZM0-25	Moeller		
OP-MPUC162	WD3	140	25.0	13.7	DILM25-01	Moeller	PKZM0-32	Moeller		

① Moeller spare parts or individual electrical components are not supplied by Danfoss

Spare parts

Unit	Filter drier		Sight glass		Pressure switch		Suction valve		Liquid valve		Fan Speed controller									
OP-MPHC010	DML082.5 DML083	023Z4568 023Z5040	SGN10s SGN+10s	014-0182 014F0182	KP17 WB	060-539766	GBC10s	009G7051	GBC10s	009G7051	RGE-Z1L4-7DS XGE-4CB1	061H3045 061H3142								
OP-MPHC012																				
OP-MPHC018																				
OP-MPHC026							DML165s DML165	023Z4581 023Z5045					SGN16s SGN+16s	014-0184 014F0184	GBC16s	009G7053	GBC16s	009G7053		
OP-MPZC030																				
OP-MPHC034																				
OP-MPZC048																				
OP-MPZC060	DML083s DML083	023Z4570 023Z5040	SGN19s SGN+19s	014-0185 014F0184	GBC18s	009G7054	GBC18s	009G7054												
OP-MPZC086	DML166s DML166	023Z4582 023Z5046							SGN19s SGN+19s	014-0185 014F0184	GBC22s	009G7055	GBC16s	009G7053						
OP-MPZC108																				
OP-MPZC136																				
OP-MPZC171																				
OP-MPZC215	DML166	023Z5046							SGN+19S	014F0185	GBC35s	009G7057	GBC18s	009G7054						
OP-MPUC125																				
OP-MPUC162															GBC 28s	009G7056	GBC18s	009G7054	XGE-4CB1	061H3142

Spare parts

Unit	Receiver volume (L)				Fan Motor (capacitor included)		Fan Blade		Fan Grill		Fan capacitor (µF)		Handling handle
	A		B										
OP-MPHC010	1.2	118U0003	1.4	118U0023	Fan motor 25 W	118U0016	Blade Ø14"	118U0017	Grill H1	118U0018	1.8	118U0019	118U0013
OP-MPHC012													
OP-MPHC018													
OP-MPHC026	4.2	118U0004	4.6	118U0024	Fan motor 68 W	118U3823*	Blade Ø16"	118U0009	Grill H2	118U0011	3.5	118U0014	
OP-MPZC030													
OP-MPHC034													
OP-MPZC048													
OP-MPZC060	7.0	118U0005	7.6	118U0025	Fan motor 120 W	118U0008	Blade Ø24"	118U0010	Grill H3	118U0012	6.0	118U0015	
OP-MPZC086													
OP-MPZC108													
OP-MPZC136									Grill H4				
OP-MPZC171													
OP-MPZC215													
OP-MPUC125	14.0	118U0006	13.6	118U0026									
OP-MPUC162													

A = Receiver without valve

B = Receiver with valve on top

*fan motor should be replaced by the old one 118U3478 (75 W) for the unit with serial number up to xxxxxxCG4812 produced before December 2012.

Electrical characteristics – 230 V, 1 phase, 50 Hz

Unit	Wiring diagram	LRA Compressor (A)	MCC Compressor (A)	Max. continuous power consumption (kW)	Contactor	Code number ① 230 V 50 Hz	Main switch	Code number ①	MCC fan (A)	Fan power (W)
OP-MPZC030	WD2	40	10	1.51	CI 9 DILM9-01	037H002131 Moeller	CTI25M PKZM0-10	047B3149 Moeller	0.47	1×68
OP-MPGC034	WD2	25.7	6.8	1.55						
OP-MPZC048	WD2	51	20	2.36						
OP-MPZC060	WD2	60	22	3.17						

Electrical characteristics – 400 V, 3 phase, 50 Hz

Unit	Wiring diagram	LRA Compressor (A)	MCC Compressor (A)	Max. continuous power consumption (kW)	Contactor	Code number ① 230 V 50 Hz	Main switch	Code number ①	MCC fan (A)	Fan power (W)
OP-MPZC030	WD3	20	5	1.51	CI 6 DILM7-01	037H001531 Moeller	CTI25M PKZM0-6.3	047B3148 Moeller	0.47	1×68
OP-MPZC048	WD3	23	7.5	2.36	CI 9 DILM9-01	037H002131 Moeller	CTI25M PKZM0-10	047B3149 Moeller		
OP-MPZC060	WD3	30	9.0	3.17						
OP-MPZC086	WD3	48.5	11.5	3.89	CI 12 DILM12-01	037H003131 Moeller	CTI25MB PKZM0-16	047B3157 Moeller	0.96	1×120
OP-MPZC108	WD3	64	15	4.86	CI 16 DILM15-01	037H004131 Moeller				
OP-MPZC136	WD3	80	19	6.39			CTI25MB PKZM0-20	047B3158 Moeller		
OP-MPZC171	WD3	90	22	7.93	CI25 DILM25-01	037H005131 Moeller	CTI25MB PKZM0-25	047B3159 Moeller	2×0.96	2×120
OP-MPZC215	WD3	105	27	9.47	CI30 DILM32-01	037H005531 Moeller				
OP-MPUC125	WD3	95	20.0	6.1	DILM17-01	Moeller	PKZM0-25	Moeller		
OP-MPUC162	WD3	140	25.0	8.2	DILM25-01	Moeller	PKZM0-32	Moeller		

① Moeller spare parts or individual electrical components are not supplied by Danfoss

Spare parts

Unit	Filter drier		Sight glass		Pressure switch		Suction valve		Liquid valve		Fan Speed controller	
OP-MPZC030	DML082,5s DML083	023Z4568 023Z5040	SGN10s SGN+10s	014-0182 014F0182	KP17 WB	060-539766	GBC16s	009G7053	GBC10s	009G7051	RGE-Z1L4-7DS XGE-4CB1	061H3045 061H3142
OP-MPGC034												
OP-MPZC048												
OP-MPZC060	DML083s DML83	023Z4570 023Z5040	GBC18s	009G7054								
OP-MPZC086	DML165s DML165	023Z4581 023Z5045	SGN16s SGN+16s	014-0184 014F0184			GBC22s	009G7055	GBC16s	009G7053		
OP-MPZC108												
OP-MPZC136												
OP-MPZC171												
OP-MPZC215	DML166s DML166	023Z4582 023Z5046	SGN19s SGN+19s	014-0185 014F0185			GBC35s	009G7057	GBC18s	009G7054	XGE-4CB1	061H3142
OP-MPUC125	DML166	023Z5046	SGN+19S	014F0185			GBC 28s	009G7056				
OP-MPUC162					GBC 35s	009G7057						

Spare parts

Unit	Receiver volume (L)				Fan Motor (capacitor included)		Fan Blade		Fan Grill		Fan capacitor (µF)		Handling handle
	A		B										
OP-MPZC030	4.2	118U0004	4.6	118U0024	Fan motor 68 W	118U3823*	Blade Ø16"	118U0009	Grill H2	118U0011	3.5	118U0014	118U0013
OP-MPGC034	1.2	118U0003	1.4	118U0023	Fan motor 25 W	118U0016	Blade Ø14"	118U0017	Grill H1	118U0018	1.8	118U0019	
OP-MPZC048	4.2	118U0004	4.6	118U0024	Fan motor 68 W	118U3823*	Blade Ø16"	118U0009	Grill H2	118U0011	3.5	118U0014	
OP-MPZC060													
OP-MPZC086	7.0	118U0005	7.6	118U0025	Fan motor 120 W	118U0008	Blade Ø24"	118U0010	Grill H3	118U0012	6.0	118U0015	
OP-MPZC108													
OP-MPZC136													
OP-MPZC171													
OP-MPZC215	14.0	118U0006	13.6	118U0026					Grill H4				
OP-MPUC125			13.6	118U0026									
OP-MPUC162													

Note:
 LRA (Locked Rotor Amps)
 MCC (Maximum Continuous Current)

A = Receiver without valve
B = Receiver with valve on top

*fan motor should be replaced by the old one 118U3478 (75 W) for the unit with serial number up to xxxxxxCG4812 produced before December 2012.

Electrical characteristics – 230 V, 1 phase, 50 Hz

Unit	Wiring diagram	LRA Compressor (A)	MCC Compressor (A)	Max. continuous power consumption (kW)	Contactor	Code number ① 230 V 50 Hz	Main switch	Code number ①	MCC fan (A)	Fan power (W)
OP-MPZC030	WD2	40	10	1.75	CI 9 DILM9-01	037H002131 Moeller	CTI25M PKZM0-10	047B3149 Moeller	0.47	1×68
OP-MPZC048	WD2	51	20	3.03	CI 15 DILM15-01	037H004931 Moeller	CTI25MB PKZM0-20	047B3158 Moeller		
OP-MPZC060	WD2	60	22	4.11	CI 20 DILM25-01	037H004531 Moeller	CTI25MB PKZM0-25	047B3159 Moeller		

Electrical characteristics – 400 V, 3 phase, 50 Hz

Unit	Wiring diagram	LRA Compressor (A)	MCC Compressor (A)	Max. continuous power consumption (kW)	Contactor	Code number ① 230 V 50 Hz	Main switch	Code number ①	MCC fan (A)	Fan power (W)
OP-MPZC030	WD3	20	5	1.75	CI 6 DILM7-01	037H001531 Moeller	CTI25M PKZM0-6.3	047B3148 Moeller	0.47	1×68
OP-MPZC048	WD3	23	7.5	3.03	CI 9 DILM9-01	037H002131 Moeller	CTI25M PKZM0-10	047B3149 Moeller		
OP-MPZC060	WD3	30	9.0	4.11			CTI25MB PKZM0-16	047B3157 Moeller		
OP-MPZC086	WD3	48.5	11.5	5.03	CI 12 DILM12-01	037H003131 Moeller	CTI25MB PKZM0-20	047B3158 Moeller	0.96	1×120
OP-MPZC108	WD3	64	15	6.38	CI 16 DILM15-01	037H004131 Moeller				
OP-MPZC136	WD3	80	19	8.60			CI 25 DILM25-01	037H005131 Moeller	047B3159 Moeller	2×0.96
OP-MPZC171	WD3	90	22	10.06	CI 30 DILM32-01	037H005531 Moeller	CTI25MB PKZM0-25	047B3159 Moeller		

① Moeller spare parts or individual electrical components are not supplied by Danfoss

Spare parts

Unit	Filter drier		Sight glass		Pressure switch		Suction valve		Liquid valve		Fan Speed controller	
OP-MPZC030	DML082,5s DML083	023Z4568 023Z5040	SGN10s SGN+10s	014-0182 014F0182	KP17 WB	060-539766	GBC16s	009G7053	GBC10s	009G7051	RGE-Z1L4-7DS XGE-4CB1	061H3045 061H3142
OP-MPZC048												
OP-MPZC060	DML083s DML083	023Z4570 023Z5040	GBC22s	009G7055			GBC16s	009G7053				
OP-MPZC086									DML165s DML165	023Z4581 023Z5045		
OP-MPZC108	GBC35s	009G7057										
OP-MPZC136			GBC18s	009G7054								
OP-MPZC171	DML166s DML166	023Z4582 023Z5046					SGN19s SGN+19s	014-0185 014F0185				
OP-MPZC215												

Spare parts

Unit	Receiver volume (L)				Fan Motor (capacitor included)		Fan Blade		Fan Grill		Fan capacitor (µF)		Handling handle
	A		B										
OP-MPZC030	4.2	118U0004	4.6	118U0024	Fan motor 68 W	118U3823*	Blade Ø16"	118U0009	Grill H2	118U0011	3.5	118U0014	118U0013
OP-MPZC048													
OP-MPZC060													
OP-MPZC086	7.0	118U0005	7.6	118U0025	Fan motor 120 W	118U0008	Blade Ø24"	118U0010	Grill H3	118U0012	6.0	118U0015	
OP-MPZC108													
OP-MPZC136									Grill H4	118U0012			
OP-MPZC171													
OP-MPZC215	14.0	118U0006	13.6	118U0026									

A = Receiver without valve

B = Receiver with valve on top

* fan motor should be replaced by the old one 118U3478 (75 W) for the unit with serial number up to xxxxxxCG4812 produced before December 2012.

Designation system for the Optyma Plus™ program

(additional program frequency etc.: please contact your local wholesaler)

1. Application
2. Design
3. Refrigerant
4. Condenser option
5. Displacement
6. Compressor platform
7. Version
8. Electrical code

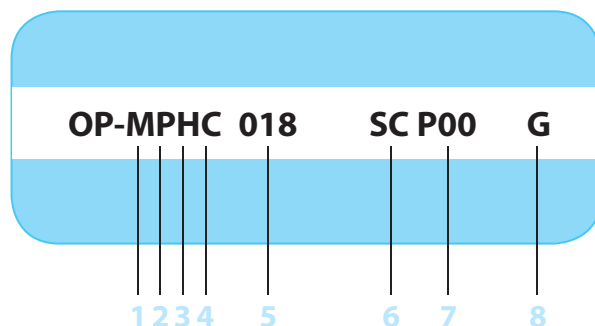

1	L = LBP M = MBP	5	026 = 26 cm ³ 171 = 171 cm ³
2	P = Packaged units	6	GS = GS (Reciprocating) MT = MTZ (Reciprocating) NT = NTZ (Reciprocating) SC = SC (Reciprocating) ML = MLZ (Scroll)
3	Z = R404A, R134a, R507, R407C H = R404A/R507 G = R134a U = R404A, R134a, R507, R22	7	P00
4	C = Standard	8	G = Compressor 230 V/1 phase/50 Hz, fan 230 V/1 phase/50 Hz E = Compressor 400 V/3 phase/50 Hz, fan 230 V/1 phase/50 Hz

@ +32°C Ambient



Cooling capacity kW

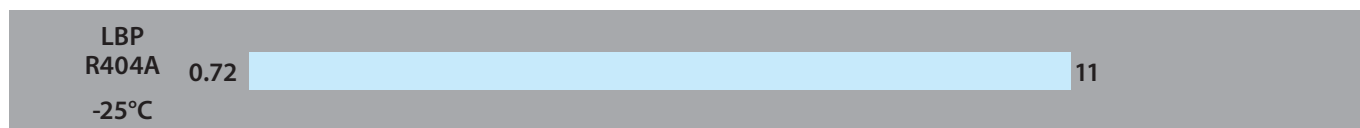

Cooling capacity kW

R404A/R507

R134a

R407C

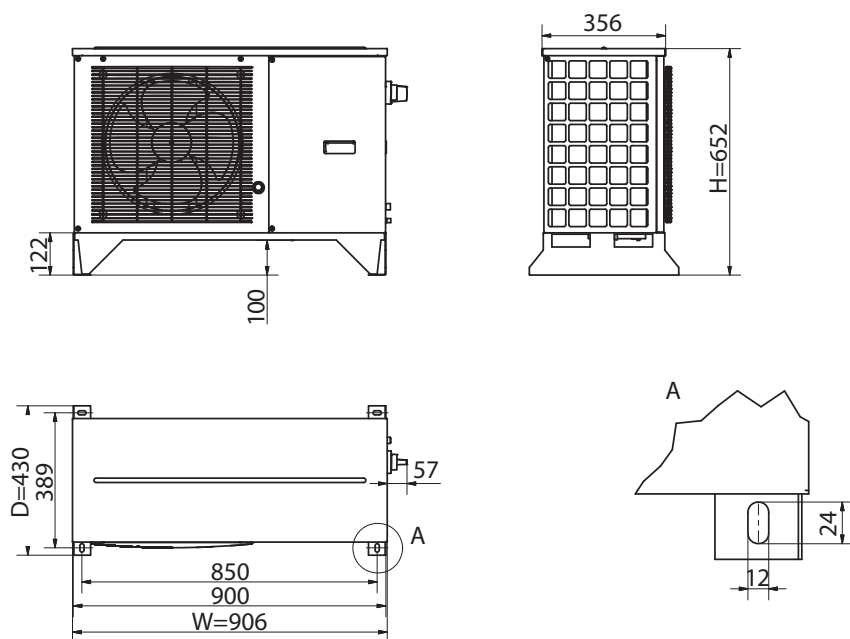

Fig. 1

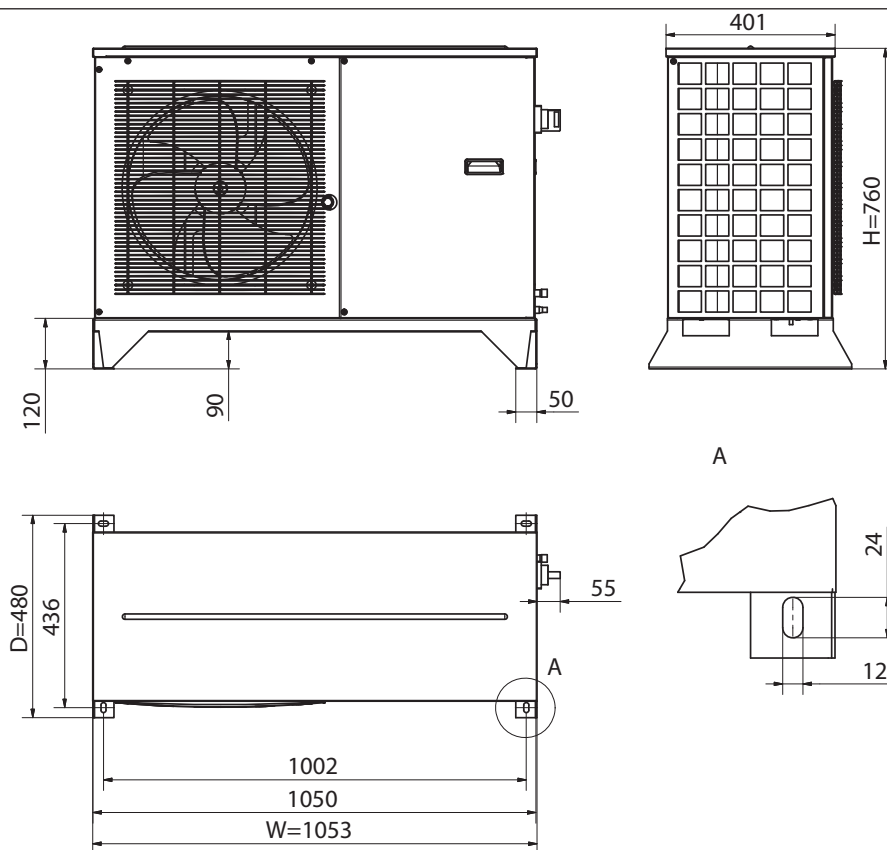
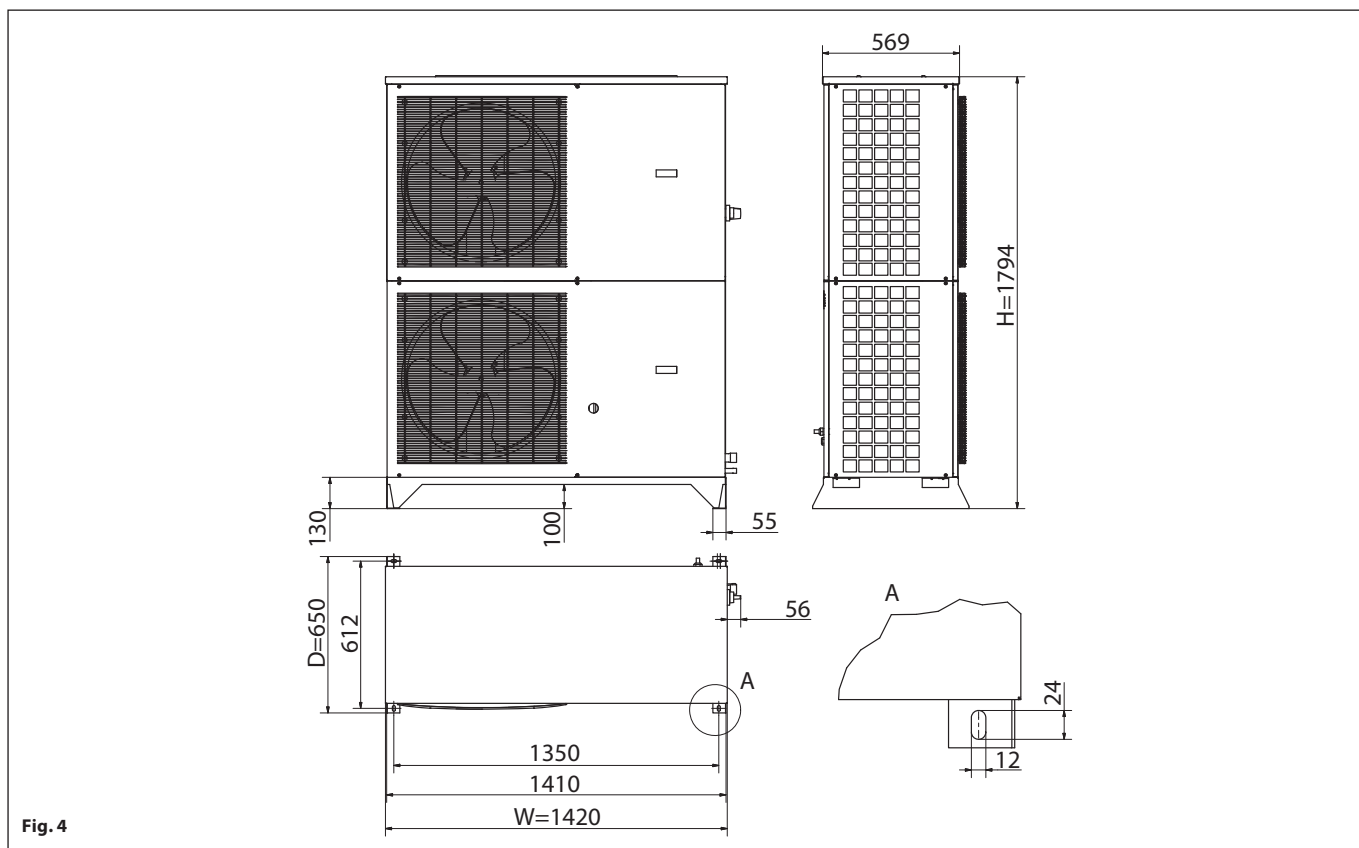
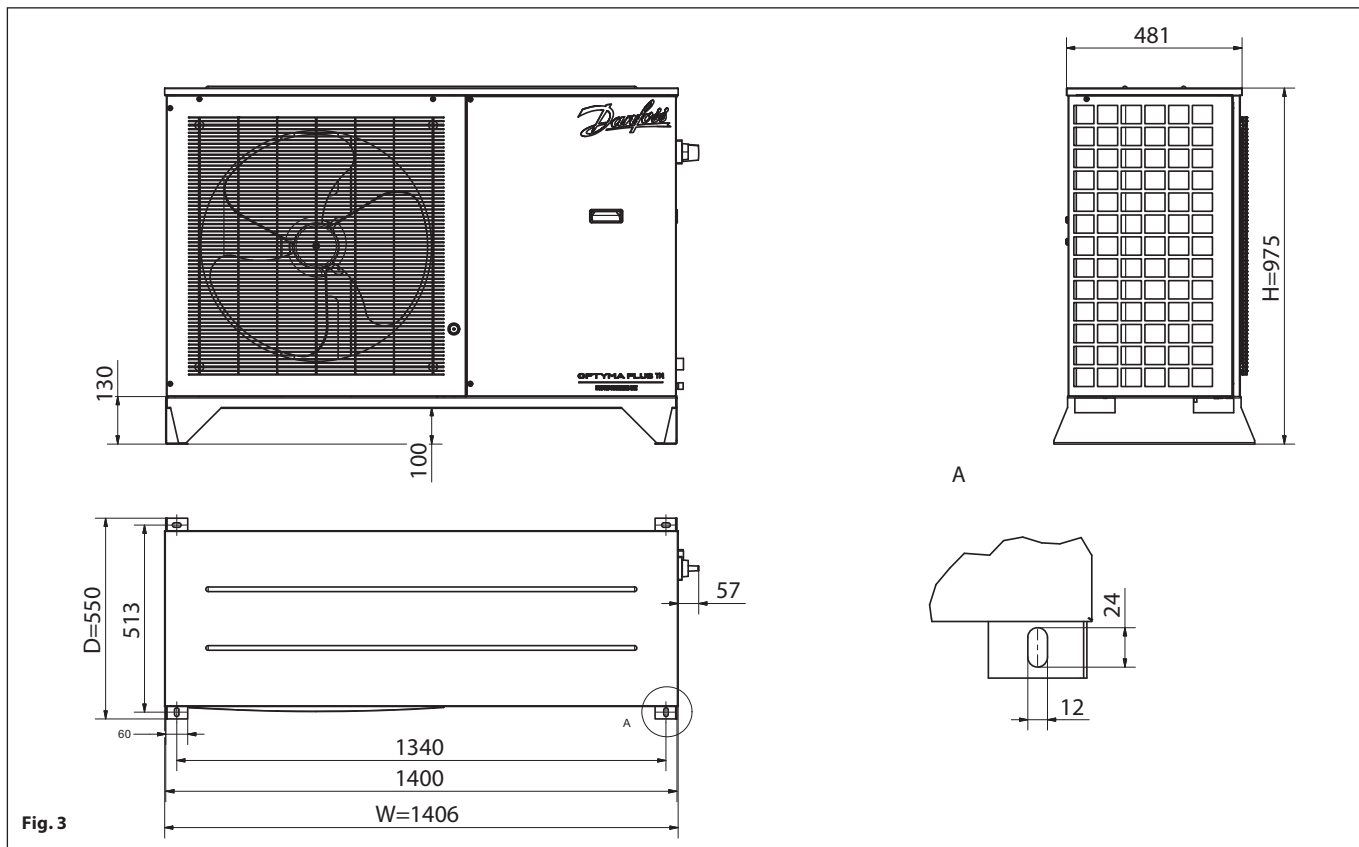
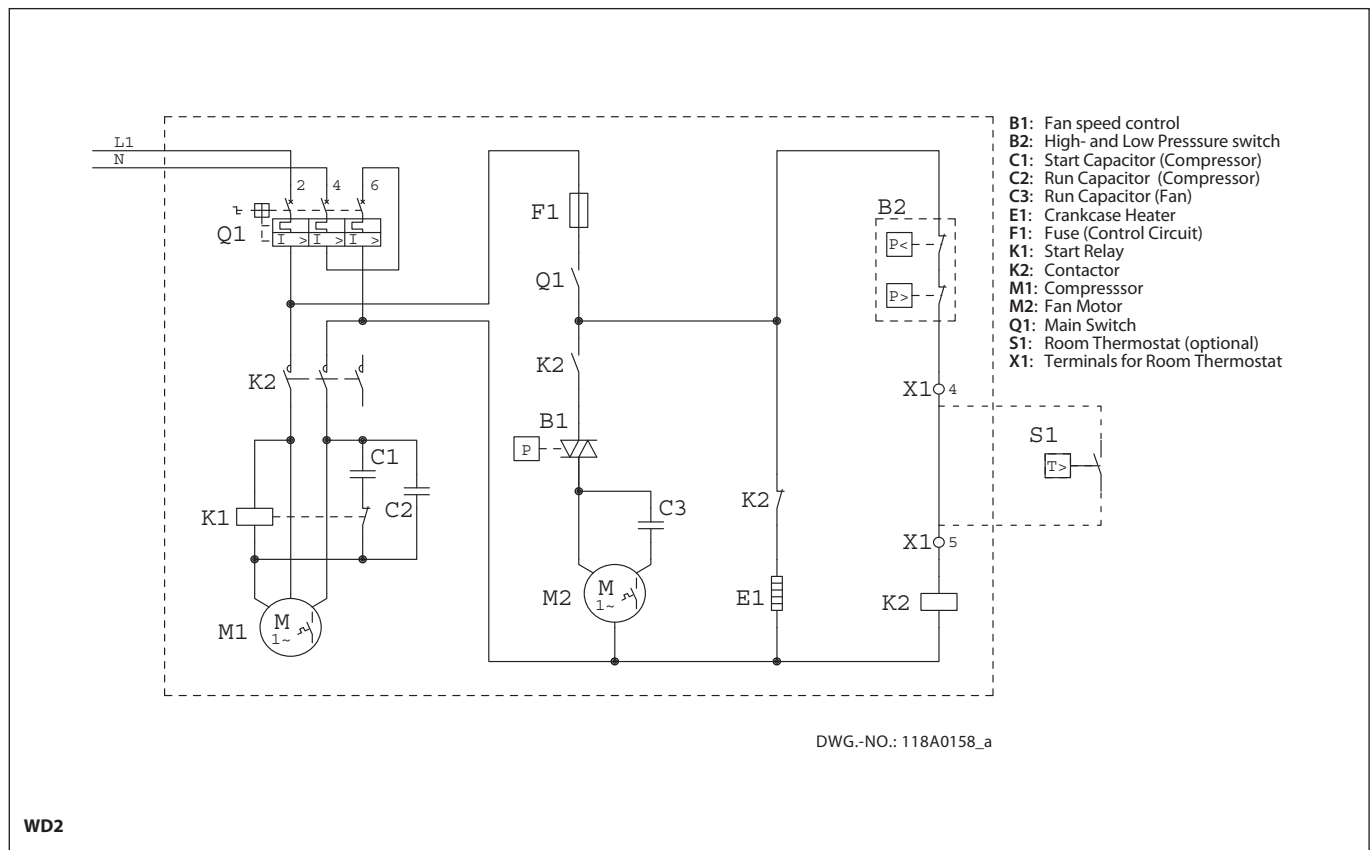
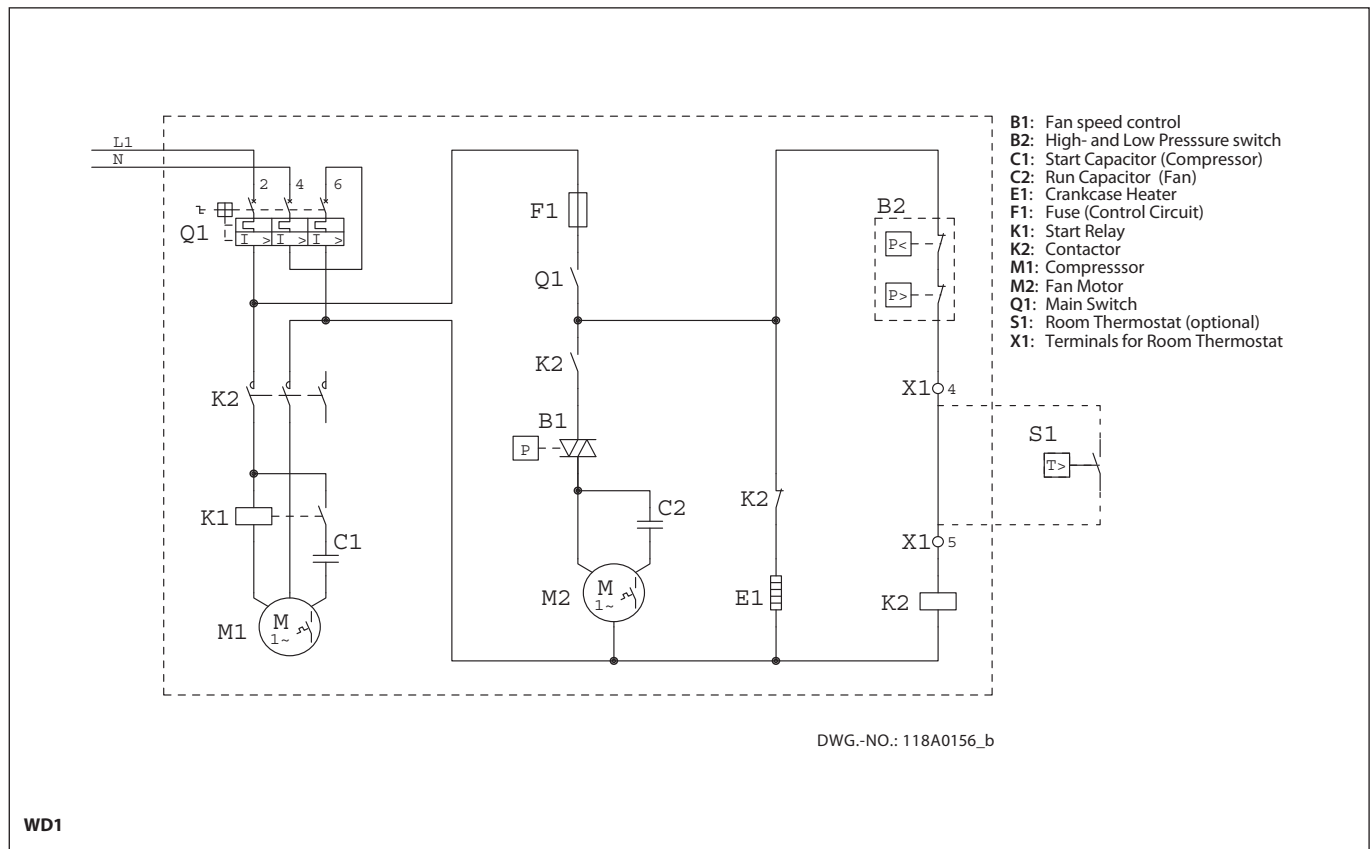
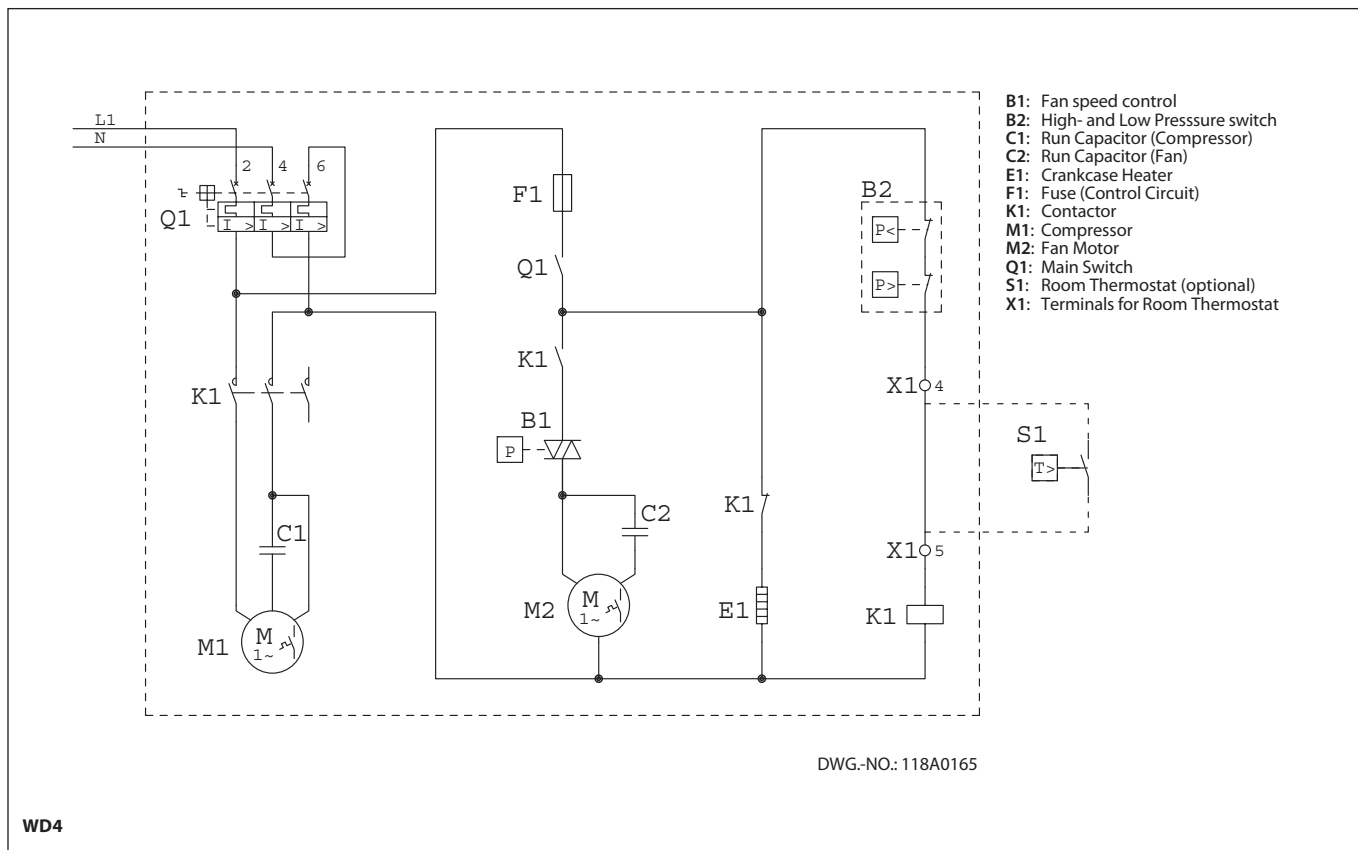
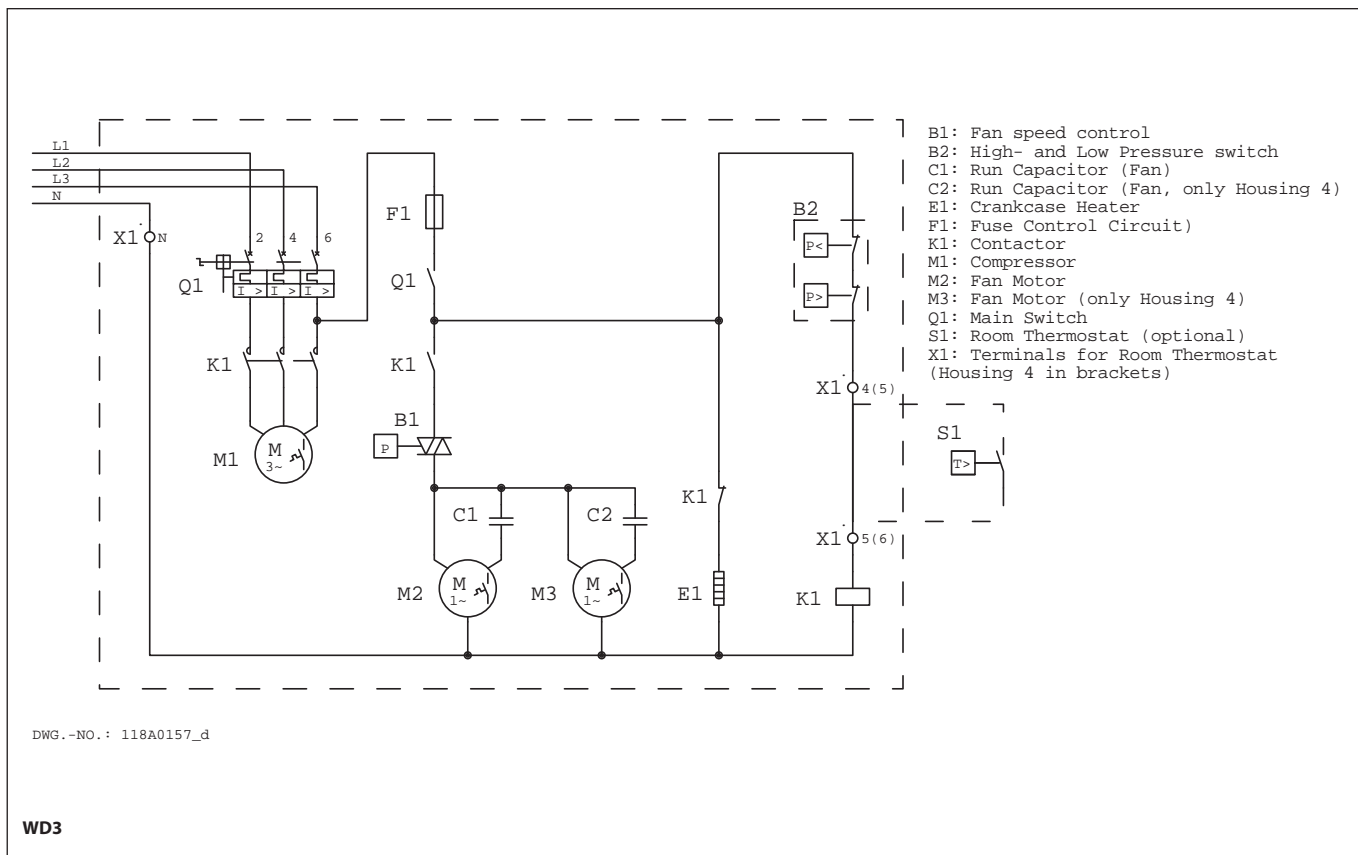

Fig. 2









Danfoss Commercial Compressors is a worldwide manufacturer of compressors and condensing units for refrigeration and HVAC applications. With a wide range of high quality and innovative products we help your company to find the best possible energy efficient solution that respects the environment and reduces total life cycle costs.

We have 40 years of experience within the development of hermetic compressors which has brought us amongst the global leaders in our business, and positioned us as distinct variable speed technology specialists. Today we operate from engineering and manufacturing facilities spread across three continents.



Danfoss Variable Speed scroll compressors



Danfoss Air Conditioning scroll compressors



Danfoss Heat Pump scroll compressors



Maneurop® Variable Speed reciprocating compressors



Danfoss Refrigeration scroll compressors



Maneurop® Reciprocating Compressors



Optyma™ & Optyma Plus™ Condensing Units



Light commercial reciprocating compressors (manufactured by Secop)

Our products can be found in a variety of applications such as rooftops, chillers, residential air conditioners, heatpumps, coldrooms, supermarkets, milk tank cooling and industrial cooling processes.

member of:



www.asercom.org

Danfoss can accept no responsibility for possible errors in catalogues, brochures and other printed material. Danfoss reserves the right to alter its products without notice. This also applies to products already on order provided that such alterations can be made without subsequential changes being necessary in specifications already agreed. All trademarks in this material are property of the respective companies. Danfoss and the Danfoss logotype are trademarks of Danfoss A/S. All rights reserved.