

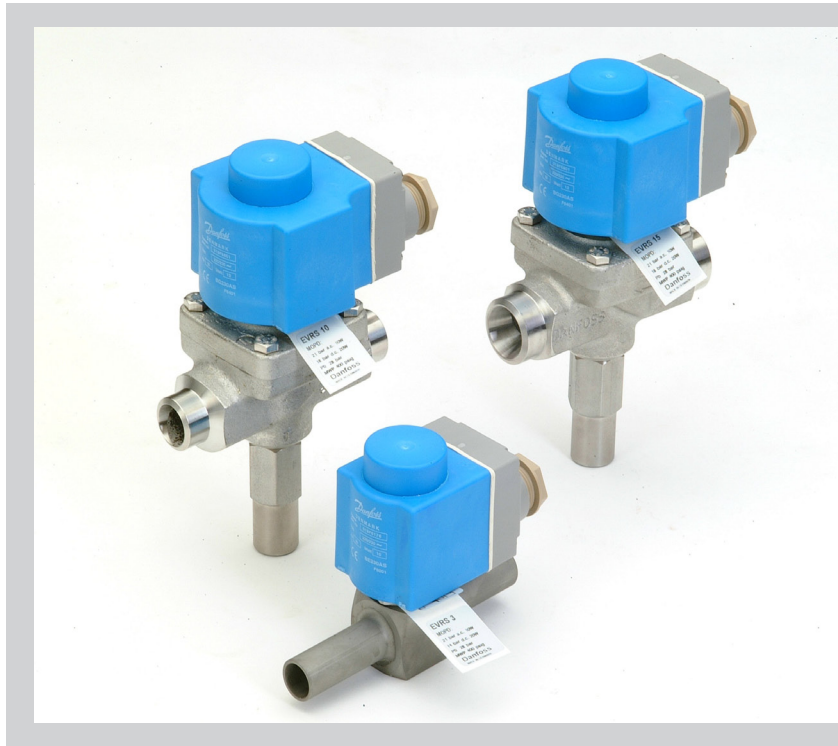

Technical brochure

Stainless steel solenoid valves

EVRS 3-20 and EVRST 10-20



EVRS and EVRST are valves made of stainless steel.

EVRS 3 is direct operated.

EVRS 10, 15 and 20 are servo operated.

EVRST 10,15 and 20 are forced servo operated valves used in liquid, suction, hot gas and oil return lines with ammonia or fluorinated refrigerants.

EVRS 3 and EVRST are designed for keeping open at a pressure drop of 0 bar.

EVRS/EVRST 10, 15 and 20 are equipped with spindle for manual opening.

EVRS and EVRST are supplied as components, i.e. valve body and coil must be separately ordered.

Features

- Stainless steel valve body and connections
- Max. working pressure 50 barg
- Applicable to HCFC, HFC, R717 (Ammonia) and R744 (CO₂).
- MOPD up to 38 bar with 20 watt a.c. coil
- Wide choice of a.c. and d.c. coils
- Designed for temperatures of media up to 105°C
- Manual stem on EVRS and EVRST 10, EVRST 15 and EVRST 20

Approvals

The Low Voltage Directive (LVD) 73/23/EC with ammendments EN 60730-2-8

Technical data

Refrigerants
Applicable to HCFC, HFC, R717 (Ammonia) and R744 (CO₂).

Temperature of medium
-40 → +105°C for 10 or 12 watt coil. Max. 130°C during defrosting.
-40 → +80°C for 20 watt coil.

Stainless steel solenoid valves type EVRS 3-20 and EVRST 10-20

Technical data

(Continued)

Ambient temperature and enclosure for coil: See "Coils for solenoid valves", lit.no. DKRCC.PD.B50.A

Type	Opening differential pressure Δp bar					k_v value ²⁾	Max. working pressure Ps
	Min.	Max. (MOPD) liquid ¹⁾					
		10 W a.c.	12 W a.c.	20 W a.c.	20 W d.c.	m ³ /h	
EVRS 3	0.0	21	25	38	14	0.23	50 barg
EVRS 10	0.05	21	25	38	18	1.5	
EVRST 10	0.0	14	21	38	16	1.5	
EVRS 15	0.05	21	25	38	18	2.7	
EVRST 15	0.0	14	21	38	18	2.7	
EVRS 20	0.05	21	25	38	13	4.5	
EVRST 20	0.0	14	21	38	13	4.5	

¹⁾ MOPD for media in gas form is approx. 1 bar greater.

²⁾ The k_v value is the water flow in m³/h at a pressure drop in the valve of 1 bar, $\rho = 1000$ kg/m³.

Type	Rated capacity ¹⁾ kW														
	Liquid					Suction vapour					Hot gas				
	R717	R22	R134a	R404A	R410A	R717	R22	R134a	R404A	R410A	R717	R22	R134a	R404A	R410A
EVRS 3	21.8	4.6	4.3	3.2	4.5						6.5	2.1	1.7	1.7	2.3
EVRS/EVRST 10	142.0	30.2	27.8	21.1	29.7	9.0	3.4	2.5	3.1	4.3	42.6	13.9	11.0	11.3	14.9
EVRS/EVRST 15	256.0	54.4	50.1	38.0	53.5	16.1	6.2	4.4	5.5	7.7	76.7	24.9	19.8	20.3	26.7
EVRS/EVRST 20	426.0	90.6	83.5	63.3	89.1	26.9	10.3	7.3	9.2	12.0	128.0	41.5	32.9	33.9	44.5

¹⁾ Rated liquid and suction vapour capacity is based on evaporating temperature $t_e = -10^\circ\text{C}$, liquid temperature ahead of valve $t_l = +25^\circ\text{C}$, and pressure drop across valve $\Delta p = 0.15$ bar.

Rated hot gas capacity is based on condensing temperature $t_c = +40^\circ\text{C}$, pressure drop across valve $\Delta p = 0.8$ bar, hot gas temperature $t_h = +60^\circ\text{C}$, and subcooling of refrigerant $\Delta t_{\text{sub}} = 4$ K.

Type	R 744 Rated capacity kW ²⁾	
	Liquid	Suction
EVRS 3	6.65	-
EVRS/ EVRST 10	43.3	6.9
EVRS/ EVRST 15	78.0	12.4
EVRS/ EVRST 20	130.0	20.7

²⁾ Rated liquid and suction vapour capacity is based on evaporating temperature $t_e = -40^\circ\text{C}$, liquid temperature ahead of the valve $t_l = -8^\circ\text{C}$ and pressure drop across the valve $\Delta p = 0.15$ bar
For other condition please refer to DIR-Calc or contact your local Danfoss office.

Ordering

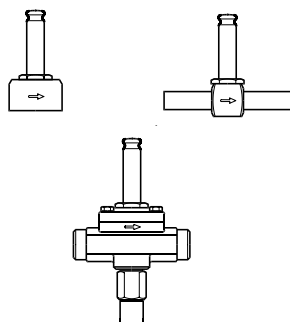

Separate valve bodies

Type	Max. working pressure Ps barg	Connection		Code no.	
		Weld in.	Pipe thread ISO 228/1	With manual stem	Without manual stem
EVRS 3	50	$\frac{3}{8}$			032F3080
EVRS 3	50		G $\frac{1}{4}$		032F3081
EVRS 10	50	$\frac{1}{2}$		032F3082	
EVRST 10	50	$\frac{1}{2}$		032F3083	
EVRS 15	50	$\frac{3}{4}$		032F3084	
EVRST 15	50	$\frac{3}{4}$		032F3085	
EVRS 20	50	1		032F5437	
EVRST 20	50	1		032F5438	

Coils See "Coils for solenoid valves", lit.no. DKRCC.PD.B50.A

Stainless steel solenoid valves type EVRS 3-20 and EVRST 10-20
Capacity

 Liquid capacity Q_l kW

Type	Liquid capacity Q_e kW at pressure drop across valve Δp bar				
	0.1	0.2	0.3	0.4	0.5

R717 (NH₃)

EVRS 3	17.8	25.1	30.8	35.6	39.8
EVRS/EVRST 10	116.0	164.0	201.0	232.0	259.0
EVRS/EVRST 15	209.0	295.0	362.0	418.0	467.0
EVRS/EVRST 20	348.0	492.0	603.0	696.0	778.0

R22

EVRS 3	3.8	5.3	6.6	7.6	8.5
EVRS/EVRST 10	24.7	34.9	42.7	49.3	55.1
EVRS/EVRST 15	44.4	62.8	76.9	88.8	99.2
EVRS/EVRST 20	73.9	105.0	128.0	148.0	165.0

R134a

EVRS 3	3.5	4.9	6.0	7.0	7.8
EVRS/EVRST 10	22.7	32.2	39.4	45.5	50.8
EVRS/EVRST 15	40.9	57.9	70.9	81.8	91.5
EVRS/EVRST 20	68.2	96.5	118.0	136.0	153.0

R404A

EVRS 3	2.6	3.7	4.6	5.3	5.9
EVRS/EVRST 10	17.2	24.3	29.8	34.4	38.5
EVRS/EVRST 15	31.0	43.8	53.7	62.0	69.3
EVRS/EVRST 20	51.7	73.0	89.5	103.0	116.0

R410A

EVRS 3	3.7	5.3	6.4	7.5	8.3
EVRS/EVRST 10	24.3	34.4	42.0	48.6	54.3
EVRS/EVRST 15	43.7	61.8	75.6	87.5	97.7
EVRS/EVRST 20	72.9	103.0	126.0	146.0	163.0

Capacities are based on liquid temperature $t_l = +25^\circ\text{C}$ ahead of valve, evaporating temperature $t_e = -10^\circ\text{C}$, and superheat 0 K.

Correction factors

When sizing valves, the plant capacity must be multiplied by a correction factor depending on liquid temperature t_l ahead of valve/evaporator. When the corrected capacity is known, the selection can be made from the table.

t_v °C	-10	0	+10	+20	+25	+30	+40	+50
R717 (NH ₃)	0.84	0.88	0.92	0.97	1.0	1.03	1.09	1.16
R22, R134a	0.76	0.81	0.88	0.96	1.0	1.05	1.16	1.31
R404A	0.70	0.76	0.84	0.94	1.0	1.07	1.24	1.47
R410A	0.73	0.79	0.86	0.95	1.0	1.06	1.23	1.47

Stainless steel solenoid valves type EVRS 3-20 and EVRST 10-20

Capacity (continued)

Suction vapour capacity Q_e kW

Type	Pressure drop across valve Δp bar	Suction vapour capacity Q_e kW at evaporating temperature t_e °C					
		-40	-30	-20	-10	0	+10

R717 (NH₃)

EVRS/EVRST 10	0.1	3.4	4.5	5.9	7.3	8.9	10.6
	0.15	4.0	5.4	7.0	9.0	10.9	13.0
	0.2	4.5	6.1	7.9	10.0	12.6	15.0
EVRS/EVRST 15	0.1	6.1	8.1	10.7	13.2	16.0	19.1
	0.15	7.2	9.7	12.5	16.1	19.6	23.4
	0.2	8.0	11.0	14.2	18.0	22.6	27.0
EVRS/EVRST 20	0.1	10.2	13.5	17.8	21.9	26.6	31.9
	0.15	12.1	16.1	20.9	26.9	32.6	39.0
	0.2	13.4	18.3	23.7	29.9	37.7	45.1

R22

EVRS/EVRST 10	0.1	1.4	1.8	2.3	2.8	3.4	4.0
	0.15	1.6	2.1	2.7	3.4	4.1	4.9
	0.2	1.8	2.4	3.1	3.8	4.8	5.6
EVRS/EVRST 15	0.1	2.5	3.2	4.1	5.0	6.1	7.2
	0.15	2.9	3.8	4.8	6.2	7.4	8.8
	0.2	3.3	4.3	5.5	6.8	8.6	10.2
EVRS/EVRST 20	0.1	4.1	5.3	6.8	8.4	10.1	12.0
	0.15	4.9	6.4	8.1	10.3	12.3	14.7
	0.2	5.5	7.2	9.2	11.4	14.3	16.9

R134a

EVRS/EVRST 10	0.1	0.87	1.2	1.6	2.1	2.6	3.2
	0.15	0.99	1.4	1.9	2.4	3.2	3.9
	0.2	1.1	1.6	2.1	2.8	3.5	4.5
EVRS/EVRST 15	0.1	1.6	2.1	2.8	3.8	4.7	5.7
	0.15	1.8	2.5	3.4	4.4	5.7	7.0
	0.2	2.0	2.8	3.8	5.0	6.3	8.1
EVRS/EVRST 20	0.1	2.6	3.6	4.7	6.3	7.8	9.6
	0.15	3.0	4.2	5.6	7.3	9.5	11.7
	0.2	3.3	4.7	6.4	8.3	10.5	13.5

R404A

EVRS/EVRST 10	0.1	1.2	1.5	2.0	2.5	3.1	3.7
	0.15	1.4	1.8	2.4	3.1	3.8	4.6
	0.2	1.6	2.1	2.7	3.4	4.3	5.3
EVRS/EVRST 15	0.1	2.1	2.7	3.6	4.5	5.5	6.6
	0.15	2.5	3.3	4.3	5.5	6.8	8.2
	0.2	2.8	3.7	4.9	6.1	7.8	9.5
EVRS/EVRST 20	0.1	3.5	4.6	6.0	7.5	9.2	11.1
	0.15	4.1	5.5	7.1	9.2	11.3	13.6
	0.2	4.6	6.2	8.1	10.2	13.0	15.8

R410A

EVRS/EVRST 10	0.1	1.9	2.3	2.9	3.5	4.2	5.0
	0.15	2.2	2.9	3.5	4.3	5.1	6.1
	0.2	2.6	3.3	4.0	5.0	5.9	7.0
EVRS/EVRST 15	0.1	3.3	4.2	5.2	6.3	7.6	9.0
	0.15	4.0	5.1	6.3	7.7	9.2	11.0
	0.2	4.7	5.9	7.3	8.9	10.7	12.7
EVRS/EVRST 20	0.1	5.6	7.0	8.6	10.5	12.6	15.0
	0.15	6.7	8.6	10.5	12.9	15.4	18.4
	0.2	7.8	9.9	12.2	14.9	17.8	21.2

Capacities are based on liquid temperature $t_l = +25^\circ\text{C}$ ahead of evaporator.
The table values refer to the evaporator capacity and are given as a function of evaporating temperature t_e and pressure drop Δp in valve.
Capacities are based on dry, saturated vapour ahead of valve.
During operation with superheated vapour ahead of valve, the capacities are reduced by 4% for each 10 K superheat.

Correction factors

When sizing valves, the evaporator capacity must be multiplied by a correction factor depending on liquid temperature t_l ahead of expansion valve.

When the corrected capacity is known, the selection can be made from the table.

t_l °C	-10	0	+10	+20	+25	+30	+40	+50
R717 (NH ₃)	0.84	0.88	0.92	0.97	1.0	1.03	1.09	1.16
R22, R134a	0.76	0.81	0.88	0.96	1.0	1.05	1.16	1.31
R404A	0.70	0.76	0.84	0.94	1.0	1.07	1.24	1.47
R410A	0.76	0.80	0.89	0.96	1.0	1.05	1.18	1.37

Stainless steel solenoid valves type EVRS 3-20 and EVRST 10-20
Capacity
(continued)

Hot gas capacity Q_e kW

Type	Pressure drop across valve Δp bar	Hot gas capacity Q_h kW				
		Evaporating temp. $t_e = -10^\circ\text{C}$. Hot gas temp. $t_h = t_e + 25^\circ\text{C}$. Subcooling $\Delta t_{\text{sub}} = 4$ K				
		Condensing temperature t_c °C				
		+20	+30	+40	+50	+60

R717 (NH₃)

EVRS 3	0.1	1.8	2.1	2.3	2.5	2.6
	0.2	2.6	2.9	3.2	3.5	3.7
	0.4	3.8	4.2	4.6	4.9	5.3
	0.8	5.1	6.0	6.5	7.1	7.6
	1.6	7.4	8.3	9.1	9.9	10.9
EVRS/EVRST 10	0.1	12.0	3.4	14.7	16.0	17.2
	0.2	17.1	19.0	20.9	22.7	24.4
	0.4	24.5	27.1	29.7	32.2	34.7
	0.8	34.0	39.0	42.6	46.1	49.5
	1.6	48.5	53.8	59.1	64.3	1.3
EVRS/EVRST 15	0.1	21.7	24.1	26.4	28.8	31.0
	0.2	30.8	34.2	37.5	40.8	44.0
	0.4	44.1	48.8	53.5	58.0	62.4
	0.8	61.2	70.3	76.7	83.0	89.1
	1.6	87.4	96.9	106.0	116.0	128.0
EVRS/EVRST 20	0.1	36.1	40.1	44.0	48.0	51.7
	0.2	51.4	57.0	62.6	68.0	73.2
	0.4	73.5	81.3	89.1	96.7	104.0
	0.8	102.0	117.0	128.0	138.0	148.0
	1.6	146.0	161.0	177.0	193.0	214.0

R22

EVRS 3	0.1	0.68	0.72	0.76	0.78	0.79
	0.2	0.97	1.0	1.1	1.1	1.1
	0.4	1.4	1.5	1.5	1.6	1.6
	0.8	1.9	2.0	2.1	2.3	2.3
	1.6	2.7	2.9	3.0	3.1	3.2
EVRS/EVRST 10	0.1	4.4	4.7	4.9	5.1	5.2
	0.2	6.3	6.7	7.0	7.2	7.3
	0.4	9.0	9.6	10.0	10.3	10.4
	0.8	12.4	13.2	13.9	14.7	14.9
	1.6	17.5	18.6	19.6	20.2	20.5
EVRS/EVRST 15	0.1	8.0	8.5	8.9	9.2	9.3
	0.2	11.4	12.1	12.6	13.0	13.2
	0.4	16.3	17.2	18.0	18.5	18.7
	0.8	22.3	23.1	24.9	26.5	26.8
	1.6	31.5	33.5	35.2	36.4	36.9
EVRS/EVRST 20	0.1	13.3	14.1	14.8	15.3	15.5
	0.2	19.0	20.1	21.0	21.7	22.0
	0.4	27.1	28.7	30.0	30.9	31.2
	0.8	37.1	38.4	44.5	44.2	44.6
	1.6	52.5	55.9	58.6	60.6	61.5

An increase in hot gas temperature t_h of 10 K reduces valve capacity approx. 2% and vice versa.

A change in evaporating temperature t_e changes valve capacity; see correction factor table below.

Correction factors

When sizing valves, the table value must be multiplied by a correction factor depending on evaporating temperature t_e .

t_e °C	-40	-30	-20	-10	0	+10
R717 (NH ₃)	0.89	0.91	0.96	1.0	1.06	1.10
R22	0.90	0.94	0.97	1.0	1.03	1.05

Stainless steel solenoid valves type EVRS 3-20 and EVRST 10-20
Capacity
(continued)
Hot gas capacity Q_h kW

Type	Pressure drop across valve Δp bar	Hot gas capacity Q_h kW				
		Evaporating temp. $t_e = -10^\circ\text{C}$. Hot gas temp. $t_h = t_e + 25^\circ\text{C}$. Subcooling $\Delta t_{\text{sub}} = 4$ K				
		Condensing temperature t_c °C				
		+20	+30	+40	+50	+60

R134a

EVRS 3	0.1	0.54	0.57	0.6	0.61	0.6
	0.2	0.77	0.82	0.85	0.86	0.85
	0.4	1.1	1.2	1.2	1.2	1.2
	0.8	1.5	1.6	1.7	1.8	1.8
	1.6	2.2	2.3	2.4	2.5	2.4
EVRSt/EVRST 10	0.1	3.5	3.7	3.9	4.0	3.9
	0.2	5.0	5.3	5.5	5.6	5.6
	0.4	7.0	7.7	7.9	8.0	7.9
	0.8	9.9	10.5	11.0	11.6	11.4
	1.6	14.3	15.1	15.7	16.0	15.9
EVRSt/EVRST 15	0.1	6.4	6.7	7.0	7.1	7.1
	0.2	9.1	9.6	10.0	10.1	10.0
	0.4	12.6	13.8	14.2	14.4	14.3
	0.8	17.9	19.0	19.8	20.8	20.5
	1.6	25.7	27.2	28.2	28.8	28.6
EVRSt/EVRST 20	0.1	10.6	11.2	11.7	11.8	11.8
	0.2	15.1	16.0	16.6	16.8	16.7
	0.4	21.0	22.9	23.7	24.0	23.8
	0.8	29.8	31.6	33.0	34.7	34.2
	1.6	42.8	45.3	47.1	47.9	47.6

R404A

EVRS 3	0.1	0.62	0.63	0.62	0.59	0.54
	0.2	0.87	0.89	0.88	0.83	0.76
	0.4	1.2	1.3	1.3	1.2	1.1
	0.8	1.7	1.7	1.7	1.7	1.5
	1.6	2.4	2.5	2.4	2.3	2.1
EVRSt/EVRST 10	0.1	4.0	4.1	4.0	3.8	3.5
	0.2	5.7	5.8	5.7	5.5	5.0
	0.4	8.1	8.2	8.2	7.8	7.0
	0.8	11.1	11.4	11.3	11.1	10.1
	1.6	15.7	16.0	15.8	15.2	13.9
EVRSt/EVRST 15	0.1	7.3	7.4	7.3	6.9	6.3
	0.2	10.2	10.4	10.3	9.8	8.9
	0.4	14.6	14.8	14.7	14.0	12.7
	0.8	20.1	20.4	20.3	20.0	18.1
	1.6	28.3	28.8	28.4	27.4	25.0
EVRSt/EVRST 20	0.1	12.1	12.3	12.1	11.5	10.5
	0.2	17.1	17.3	17.2	16.3	14.9
	0.4	24.4	24.7	24.5	23.3	21.1
	0.8	33.4	34.0	33.9	33.3	30.2
	1.6	47.1	48.0	47.4	45.6	41.6

An increase in hot gas temperature t_h of 10 K reduces valve capacity approx. 2% and vice versa.

A change in evaporating temperature t_e changes valve capacity; see correction factor table below.

Correction factors

When sizing valves, the table value must be multiplied by a correction factor depending on evaporating temperature t_e .

t_e °C	-40	-30	-20	-10	0	+10
R404A	0.86	0.88	0.93	1.0	1.03	1.07
R134a	0.88	0.92	0.98	1.0	1.04	1.08

Stainless steel solenoid valves type EVRS 3-20 and EVRST 10-20
Capacity
(continued)

Hot gas capacity Q_h kW

Type	Pressure drop across valve Δp bar	Hot gas capacity Q_h kW				
		Evaporating temp. $t_e = -10^\circ\text{C}$. Hot gas temp. $t_h = t_c + 25^\circ\text{C}$. Subcooling $\Delta t_{\text{sub}} = 4$ K				
		Condensing temperature t_c °C				
		+20	+30	+40	+50	+60

R410A

EVRS 3	0.1	0.8	0.8	0.8	0.8	0.7
	0.2	1.1	1.1	1.1	1.1	1.0
	0.4	1.6	1.6	1.6	1.6	1.5
	0.8	2.2	2.7	2.2	2.2	2.1
	1.6	3.1	3.2	3.2	3.2	2.9
EVRS/EVRST 10	0.1	5.1	5.2	5.3	5.2	4.8
	0.2	7.2	7.4	7.4	7.3	6.8
	0.4	10.2	10.4	10.5	10.3	9.6
	0.8	14.4	14.8	14.9	14.5	13.7
	1.6	20.3	20.8	21.0	20.5	19.1
EVRS/EVRST 15	0.1	9.2	9.4	9.4	9.3	8.6
	0.2	13.0	13.3	13.3	13.1	12.2
	0.4	18.4	18.8	18.9	18.5	17.2
	0.8	25.9	26.6	26.7	26.1	24.6
	1.6	36.6	37.5	37.8	36.9	34.5
EVRS/EVRST 20	0.1	15.3	15.7	15.8	15.5	14.4
	0.2	21.6	22.1	22.2	21.8	20.3
	0.4	30.6	31.3	31.5	30.8	28.7
	0.8	43.2	44.3	44.6	43.5	41.0
	1.6	61.0	62.6	63.0	61.6	57.4

An increase in hot gas temperature t_h of 10 K reduces valve capacity approx. 2% and vice versa.

A change in evaporating temperature t_e changes valve capacity; see correction factor table below.

Correction factors

When sizing valves, the table value must be multiplied by a correction factor depending on evaporating temperature t_e .

t_e °C	-40	-30	-20	-10	0	+10
R410A	0.92	0.95	0.98	1.0	1.02	1.03

Stainless steel solenoid valves type EVRS 3-20 and EVRST 10-20
Capacity
(continued)
Hot gas capacity G_h kg/s

Type	Hot gas temperature t_h °C	Condensing temperature t_c °C	Hot gas capacity G_h kg/s at pressure drop across valve Δp bar							
			0.5	1	2	3	4	5	6	7

R717 (NH₃)

EVRS 3	90	25	0.003	0.005	0.006	0.007	0.007	0.007	0.007	0.007	0.007	0.007
		35	0.004	0.005	0.007	0.009	0.009	0.01	0.01	0.01	0.01	0.01
		45	0.005	0.006	0.009	0.01	0.011	0.012	0.012	0.013	0.013	0.013
EVRS/ EVRST 10		25	0.022	0.03	0.04	0.045	0.048	0.048	0.048	0.048	0.048	0.048
		35	0.026	0.036	0.048	0.056	0.061	0.064	0.065	0.065	0.065	0.065
		45	0.030	0.041	0.056	0.066	0.074	0.079	0.083	0.085	0.086	
EVRS/ EVRST 15		25	0.040	0.054	0.072	0.081	0.086	0.087	0.087	0.087	0.087	0.087
		35	0.046	0.064	0.086	0.100	0.109	0.115	0.117	0.117	0.117	0.117
		45	0.053	0.074	0.101	0.120	0.133	0.142	0.149	0.153	0.155	
EVRS/ EVRST 20	25	0.066	0.090	0.120	0.120	0.144	0.145	0.145	0.145	0.145	0.145	
	35	0.077	0.107	0.144	0.167	0.182	0.191	0.195	0.195	0.195	0.195	
	45	0.089	0.124	0.169	0.199	0.211	0.237	0.248	0.255	0.258		

R22

EVRS 3	90	25	0.008	0.011	0.014	0.016	0.017	0.017	0.017	0.017	0.017	0.017
		35	0.009	0.012	0.017	0.019	0.021	0.022	0.022	0.022	0.022	0.022
		45	0.010	0.014	0.019	0.022	0.025	0.026	0.027	0.028	0.028	
EVRS/ EVRST 10		25	0.051	0.069	0.092	0.104	0.109	0.111	0.111	0.111	0.111	0.111
		35	0.058	0.08	0.108	0.125	0.136	0.142	0.144	0.144	0.144	0.144
		45	0.066	0.092	0.125	0.146	0.162	0.172	0.179	0.183	0.183	
EVRS/ EVRST 15		25	0.091	0.125	0.165	0.187	0.197	0.199	0.199	0.199	0.199	0.199
		35	0.105	0.144	0.194	0.225	0.244	0.256	0.258	0.258	0.258	0.258
		45	0.119	0.165	0.224	0.263	0.291	0.31	0.322	0.329	0.330	
EVRS/ EVRST 20	25	0.152	0.208	0.275	0.311	0.328	0.332	0.332	0.332	0.332	0.332	
	35	0.174	0.241	0.323	0.375	0.407	0.425	0.431	0.431	0.431	0.431	
	45	0.193	0.275	0.374	0.439	0.485	0.516	0.537	0.548	0.550		

R134a

EVRS 3	60	25	0.007	0.009	0.011	0.012	0.012					
		35	0.009	0.011	0.014	0.016	0.016	0.016	0.016			
		45	0.01	0.012	0.018	0.02	0.021	0.021	0.021	0.021	0.021	0.021
EVRS/ EVRST 10		25	0.048	0.06	0.074	0.077	0.077					
		35	0.055	0.071	0.092	0.103	0.104	0.104	0.135	0.135	0.135	0.135
		45	0.06	0.084	0.111	0.127	0.134	0.135	0.135	0.135	0.135	0.135
EVRS/ EVRST 15		25	0.081	0.108	0.134	0.14	0.14					
		35	0.094	0.129	0.166	0.192	0.187	0.187	0.187	0.187	0.187	0.187
		45	0.108	0.151	0.2	0.228	0.241	0.244	0.244	0.244	0.244	0.244
EVRS/ EVRST 20	25	0.134	0.180	0.223	0.233	0.233						
	35	0.157	0.215	0.276	0.307	0.312	0.312	0.312	0.312	0.312	0.312	
	45	0.181	0.252	0.333	0.381	0.403	0.407	0.407	0.407	0.407	0.407	

R404A

EVRS 3	60	25	0.01	0.013	0.018	0.021	0.022	0.023	0.023	0.023	0.023	0.023
		35	0.011	0.015	0.02	0.024	0.027	0.028	0.029	0.029	0.029	0.03
		45	0.012	0.017	0.023	0.028	0.032	0.034	0.035	0.036	0.036	0.037
EVRS/ EVRST 10		25	0.063	0.087	0.116	0.134	0.145	0.148	0.149	0.149	0.149	0.149
		35	0.072	0.1	0.134	0.158	0.174	0.184	0.19	0.19	0.19	0.192
		45	0.081	0.112	0.153	0.182	0.203	0.228	0.228	0.237	0.239	
EVRS/ EVRST 15		25	0.113	0.157	0.21	0.242	0.26	0.267	0.269	0.269	0.269	0.269
		35	0.129	0.18	0.242	0.285	0.313	0.332	0.341	0.342	0.346	0.346
		45	0.146	0.202	0.275	0.327	0.365	0.393	0.411	0.424	0.431	
EVRS/ EVRST 20	25	0.189	0.262	0.350	0.403	0.433	0.445	0.449	0.449	0.449	0.449	
	35	0.215	0.300	0.404	0.474	0.521	0.552	0.569	0.570	0.576	0.576	
	45	0.243	0.337	0.459	0.545	0.609	0.656	0.684	0.707	0.719		

R410A

EVRS 3	90	25	0.009	0.013	0.018	0.022	0.025	0.028	0.031	0.031	0.031
		35	0.010	0.014	0.020	0.025	0.029	0.032	0.035	0.038	0.038
		45	0.012	0.016	0.023	0.029	0.033	0.037	0.040	0.044	0.047
EVRS/ EVRST 10		25	0.059	0.083	0.117	0.144	0.166	0.185	0.201	0.201	0.201
		35	0.067	0.094	0.133	0.163	0.189	0.211	0.231	0.249	0.249
		45	0.076	0.108	0.152	0.186	0.215	0.241	0.263	0.285	0.304
EVRS/ EVRST 15		25	0.106	0.150	0.211	0.259	0.300	0.334	0.361	0.361	0.361
		35	0.120	0.170	0.240	0.294	0.340	0.380	0.416	0.449	0.449
		45	0.137	0.194	0.274	0.335	0.387	0.433	0.474	0.513	0.548
EVRS/ EVRST 20	25	0.177	0.149	0.352	0.431	0.498	0.556	0.602	0.602	0.602	
	35	0.200	0.283	0.400	0.490	0.566	0.633	0.693	0.748	0.748	
	45	0.228	0.323	0.456	0.558	0.645	0.722	0.790	0.854	0.913	

An increase in hot gas temperature t_h of 10 K reduces valve capacity approx. 2% and vice versa.

**Design
Function**

- 4. Coil
- 16. Armature
- 18. Pilot valve plate
- 20. Earth terminal
- 24. Connection for flexible steel hose
- 28. Gasket
- 29. Pilot orifice
- 36. DIN plug
- 40. Terminal box
- 43. Valve cover
- 44. O-ring
- 45. Valve cover gasket
- 49. Valve body
- 51. Cover
- 53. Manual operating spindle
- 73. Equalization hole
- 80. Diaphragm
- 82. Support washer
- 83. Valve seat
- 84. Main valve plate

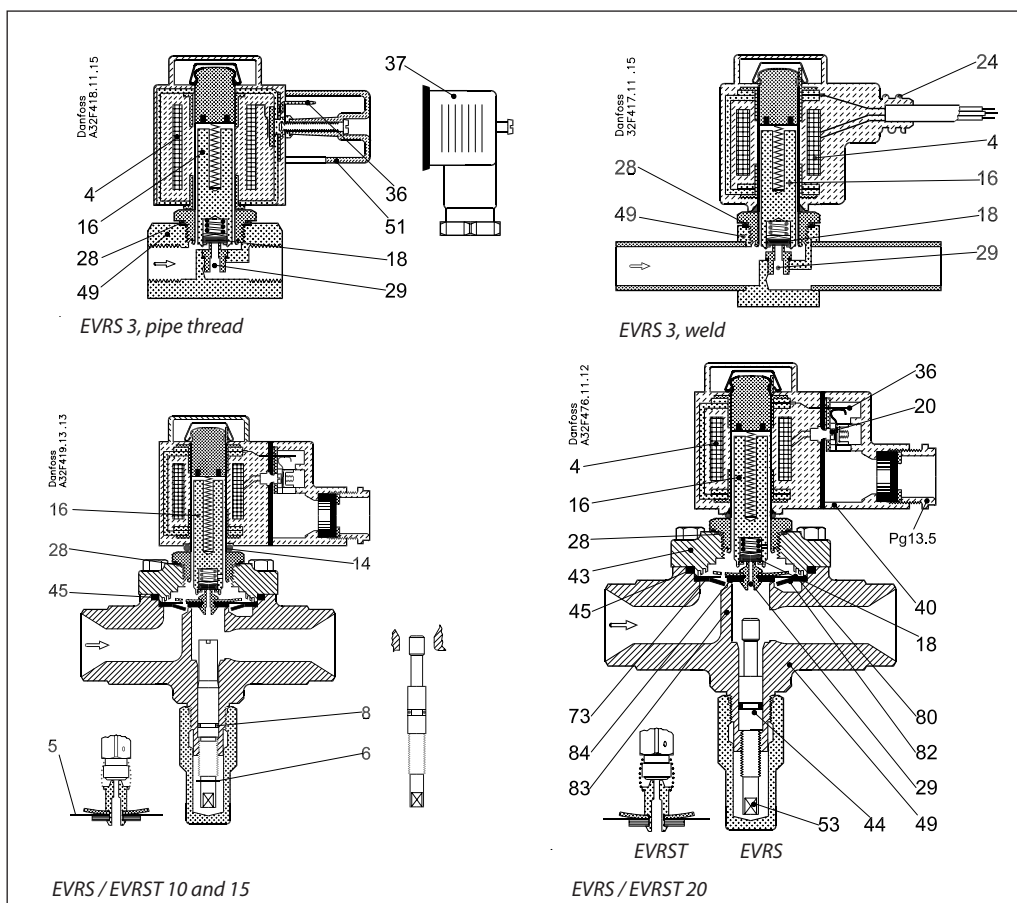

The solenoid valve design is based on three different principles:

1. Direct operation
2. Servo operation
3. Forced servo operation

1. Direct operation

EVRS 3 is directly operated. The valve opens direct for full flow when the armature (16) moves up into the magnetic field of the coil. This means that the valve operates with a min. differential pressure of 0 bar.

The valve plate (18) made of teflon and is fitted direct to the armature (16).

Inlet pressure acts from above on the armature and with it the valve plate. Thus, inlet pressure, spring force and the weight of the armature act to close the valve when the coil is currentless.

2. Servo operation

EVRS 10, 15 and 20 are servo operated with a "floating" diaphragm (80). The pilot orifice (29), which is of stainless steel, is placed in the centre of the diaphragm.

The teflon pilot valve plate (18) is fitted direct to the armature (16).

With the coil currentless, the main orifice and pilot orifice are closed.

The pilot orifice and main orifice are held closed by the weight of the armature, the armature spring force and the differential pressure between inlet and outlet sides.

When current is applied to the coil the armature is drawn up into the magnetic field and opens the pilot orifice. This relieves the pressure above the diaphragm because the space above the diaphragm becomes connected to the outlet side of the valve.

The differential pressure between inlet and outlet sides then presses the diaphragm away from the main orifice which opens to full flow.

Thus a certain minimum differential pressure is necessary to open the valve and keep it open. For EVRS 10, 15 and 20 valves this differential pressure is 0.05 bar.

When current is switched off, the pilot orifice closes. Then the pressure above the diaphragm rises, via the equalization holes (73) in the diaphragm, to the inlet pressure and causes the diaphragm to close the main orifice.

3. Forced servo operation

EVRST 10, 15 and 20 are forced servo operated solenoid valves.

Forced servo operation differs from servo operation in that in a forced servo operated valve the armature and the diaphragm are connected by a spring. Thus the armature helps to lift the diaphragm (80) and keep it lifted so that the pressure drop in the open valve is the least possible. These types of valves therefore require no differential pressure to keep them open.

Stainless steel solenoid valves type EVRS 3-20 and EVRST 10-20

Material specification

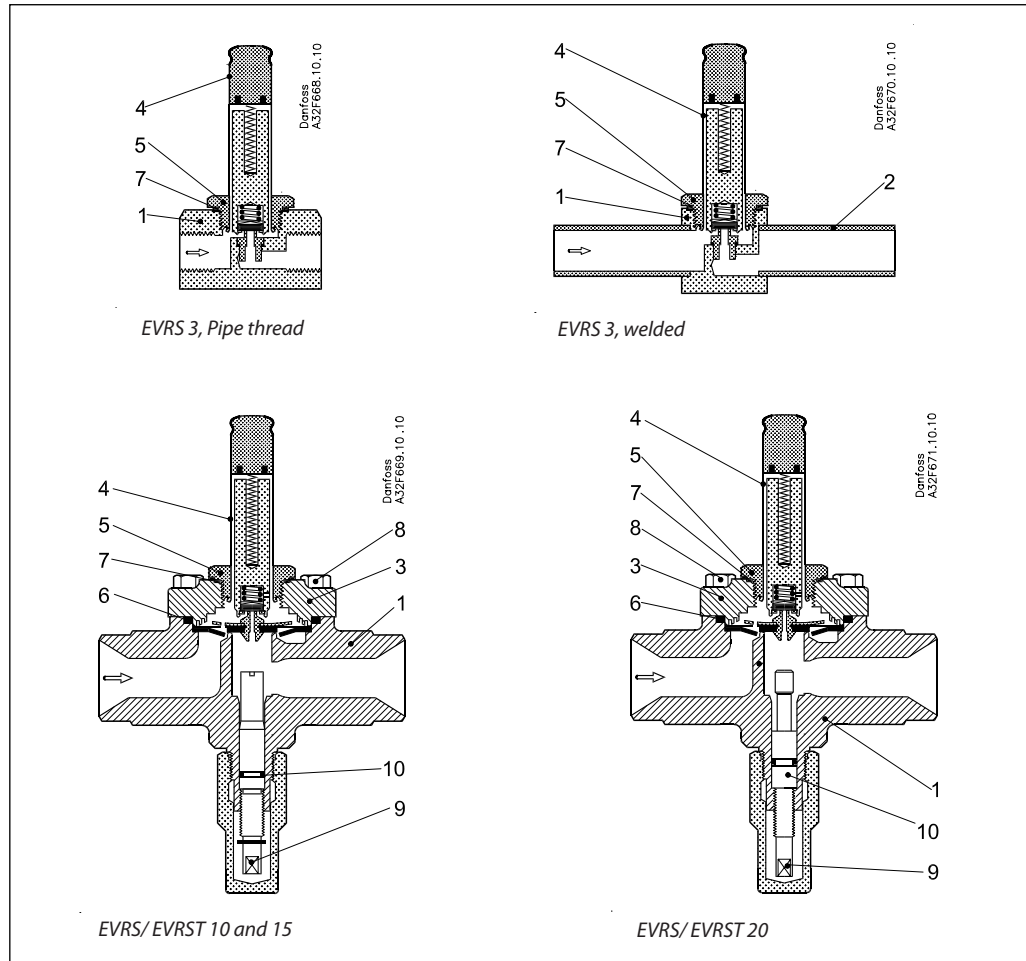

		Solenoid valves				Standard		
No.	Description	Type	Material	Analysis	Mat.no.	W.no.	DIN	EN
1	Valve housing	EVRS 3	Stainless steel	X8 CrNiS 18-9		1.4305		10088
		EVRS (T) 10/15/20	Stainless steel	X6 CrNi 18-9		1.4308	17455	
2	Welding tube	EVRS 3	Stainless steel	X2 CrNiMo 17-12-2		1.4404	17455	
3	Cover	EVRS (T) 10/15/20	Stainless steel	X6 CrNi 18-9		1.4308	17455	
4	Armature tube	EVRS(T) 3/10/15/20	Stainless steel	X2 CrNi 19-11		1.4306		10088
5	Armature tube nut	EVRS(T) 3/10/15/20	Stainless steel	X8 CrNi 19-11		1.4305		10088
6	Gasket	EVRS(T) 3/10/15/20	Rubber	Cr				
7	Gasket armature tube	EVRS(T) 10/15/20	Al gasket	Al 99.5		3.0255		10210
8	Screws	EVRS(T) 10/15/20	Stainless steel	A2-70			3506	
9	Spindle for man. oper.	EVRS(T) 10/15/20	Stainless steel	X8 CrNiS 18-9		1.4305		10088
10	Gasket	EVRS(T) 10/15/20	Rubber	Cr				

Stainless steel solenoid valves type EVRS 3-20 and EVRST 10-20

Dimensions and weights

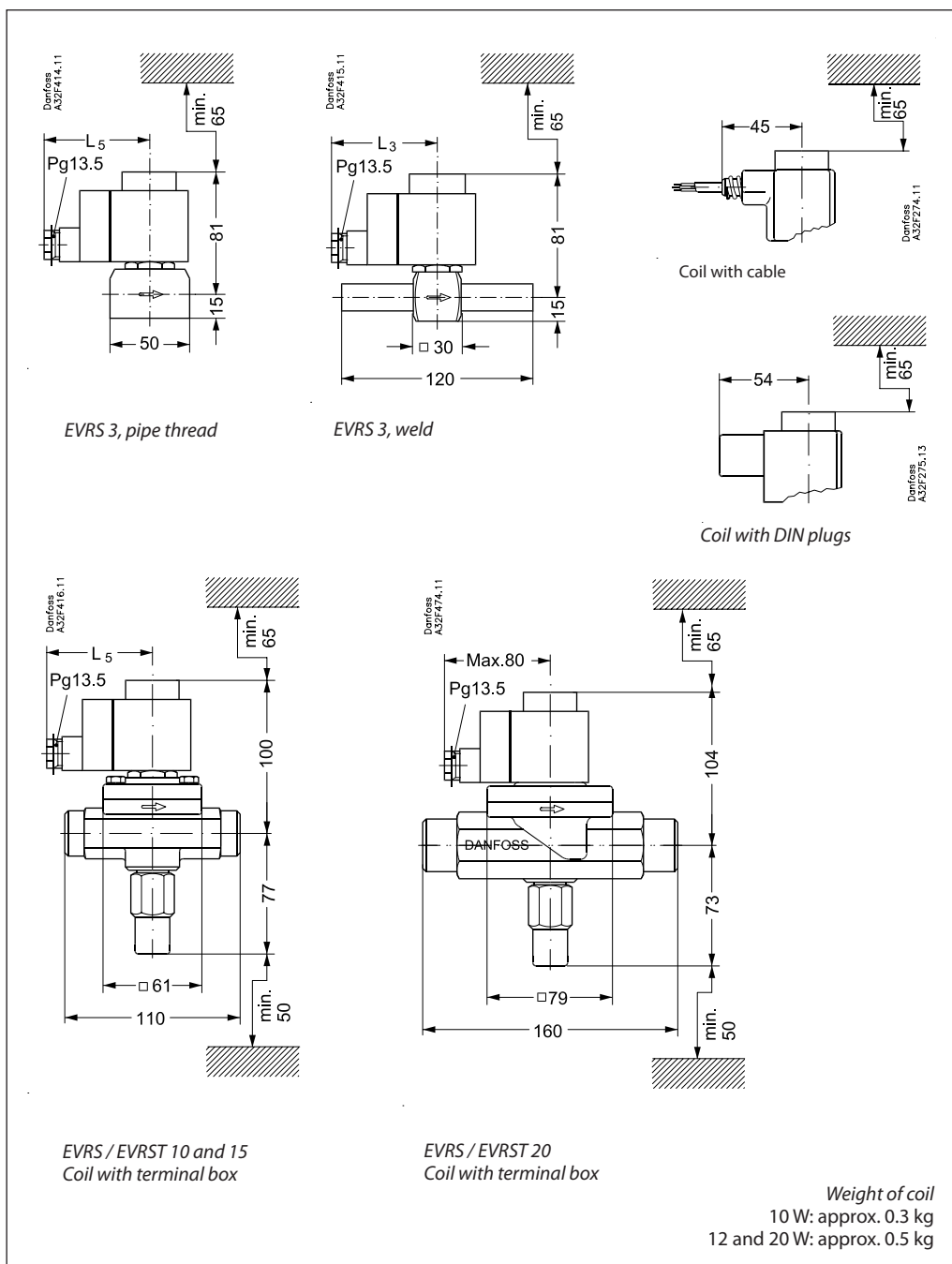

Type	L ₅ max.		Weight with coil kg
	10 W	12 W 20 W	
	mm	mm	
EVRS 3, pipe thread	75	85	0.7
EVRS 3, weld	75	85	0.6
EVRS/EVRST 10	75	85	1.2
EVRS/EVRST 15	75	85	1.3
EVRS/EVRST 20	75	85	2.0

