

Installation Guide

Pressure Control, types KP 1, KP 1W, KP 1A, KP 2, KP 5, KP 5A, KP 6W, KP 6B, KP 6S, KP 6AW, KP 6AB, KP 6AS, KP 7W, KP 7B, KP 7S

060R9306

Refrigerants

KP 1, KP 1W, KP 2, KP 5, KP 6W, KP 6B, KP 6S, KP 7W, KP 7B, KP 7S:
HCFC and non-flammable HFC

KP 1A, KP 5A, KP 6AW, KP 6AB, KP 6AS:
R717, HCFC and non-flammable HFC

KP 1, KP 2,
KP 5, KP 6, KP 7

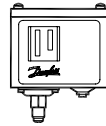

KP 1, KP 2,
KP 5, KP 6, KP 7

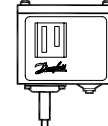

KP 1A, KP 5A

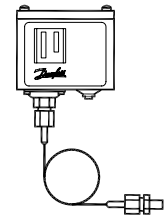

Ambient temperatures / Mounting requirements

-40 – 65 °C
-25 – 65 °C (PED approved units)

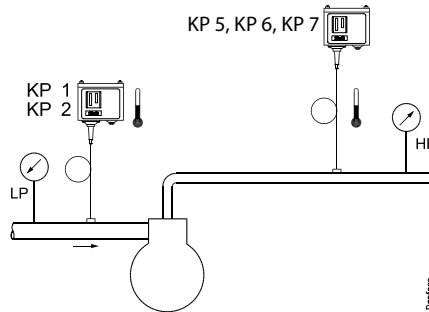
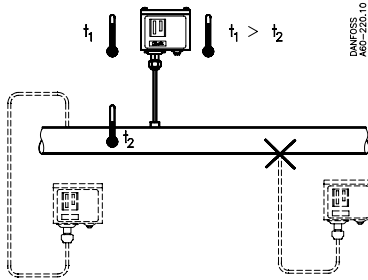

Relative humidity RH: 30 – 98%
Vibrations resistance: 4 g (10 – 1000 Hz)

Connections

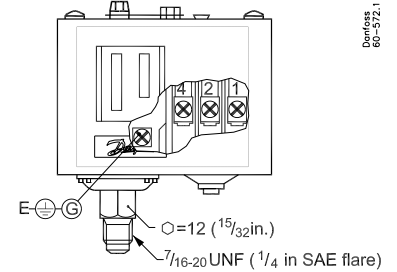

Connections for KP 1A, KP 5A, KP 6AS

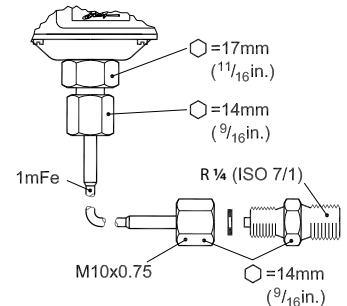

Test pressure (P_{test}) PS/MWP

P_{test,max.}:
 KP 1, KP 2: 20 bar p_e (285 psig)
 KP 2: 12 bar p_e (174 psig)
 KP 5, KP 7: 35 bar p_e (510 psig)
 KP 6: 46,5 bar p_e (675 psig)

Type	Regulation range	PS/MWP
KP 1	-0.2 – 7.5 bar	17 bar / 245 psig
KP 1, reset	-0.9 – 7.0 bar	17 bar / 245 psig
KP 1 W	0.5 – 3.0 bar	17 bar / 245 psig
KP 2	-0.2 – 5.0 bar	17 bar / 245 psig
KP 2	-0.2 – 3.5 bar	10 bar / 145 psig
KP 5	8 – 32 bar	510 psig / 35 bar
KP 6	8 – 42 bar	675 psig / 46,5 bar
KP 7	8 – 32 bar	510 psig / 35 bar

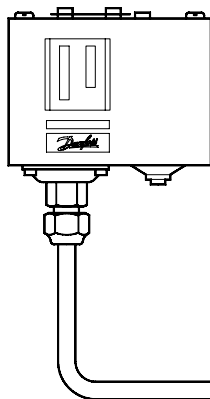

PS/MWP
(Maximum Working Pressure)

Mounting

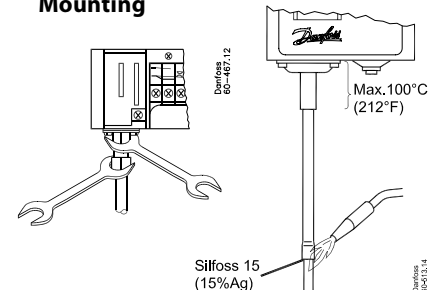

Enclosure

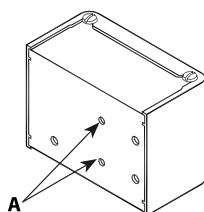

A: 8 – 32 UNC (M4)

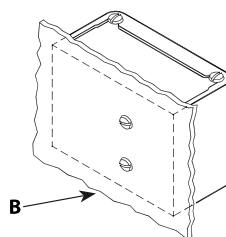

B: Enclosure IP30
(EN 60529)

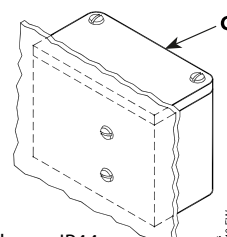

C: Enclosure IP44
(EN 60529)

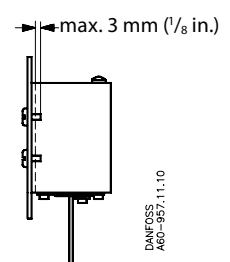

DANFOSS
AG-957.11.10



CAUTION:

Disconnect power supply before wiring connections are made or service to avoid possible electrical shock or damage to equipment. Do never touch live parts with your fingers or with any tool.

Contact 1-4 opens on pressure drop

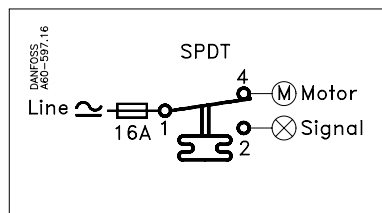

KP 1, KP 2

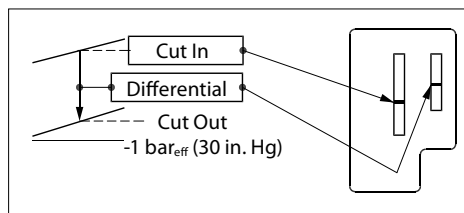

AC 1	16A / 400V a.c.	DC 13
AC 3	16A / 400V a.c.	12 W
AC 15	10A / 230V a.c.	220 V

Short circuit protection:
Fuse 16 Amp.

Contact 1-4 opens on pressure drop

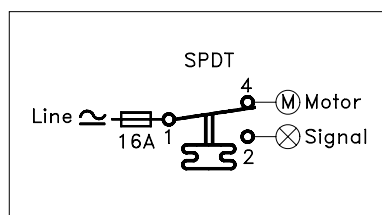

KP 1W, KP 1 manual reset

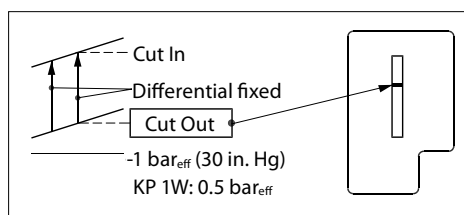

When used acc. to UL regulations

US LISTED Listed refrigeration controller 61B5

Voltage	FL	LR	Resist. load	Pilot duty
AC	DC	A	A	
240	—	8	48	8 A
120	—	16	96	16 A
—	240	—	—	—
				3A
				12 W

Contact 1-2 opens on pressure rise

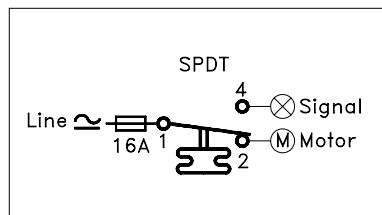

KP 5, KP 5A, KP 6, KP 6A, KP 7

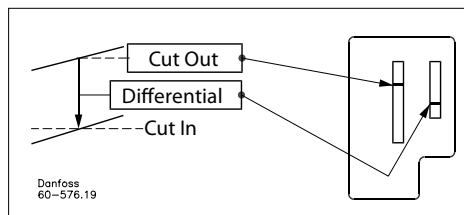

Use copper wire only
Tightening torque 20 lb. in.

Manual trip function

Automatic reset

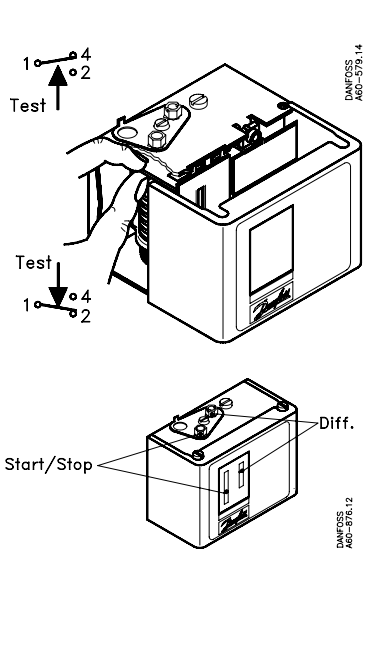

Manual reset

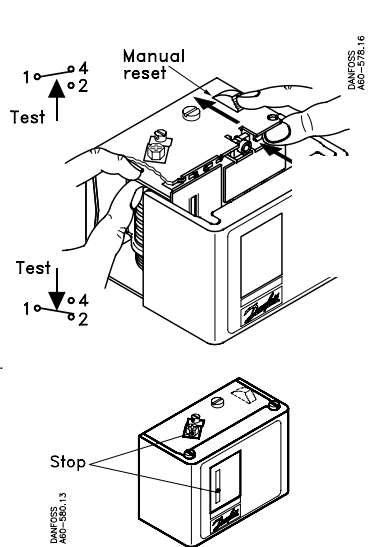

Type	Differential
KP 1, KP 1A	0.7 bar (10 psi)
KP 5, KP 5A	3 bar (43 psi)
KP 6B, KP 6S, KP 6AB, KP 6AS, KP 7B, KP 7S	4 bar (58 psi)

Note:
use FINGERS ONLY!
(Do NOT use screwdriver)

Adjustment

