



Data sheet

Pressure control Type KP



KP pressure controls are for use in refrigeration and air conditioning systems to give protection against excessively low suction pressure or excessively high discharge pressure.

KP pressure controls are also used for starting and stopping refrigeration compressors and fans on air-cooled condensers.

A KP pressure control can be connected directly to a single-phase AC motor of up to approx. 2 kW or installed in the control circuit of DC motors and large AC motors.

KP pressure controls are fitted with a single-pole double-throw (SPDT) switch. The position of the switch is determined by the pressure control setting and the pressure at the connector.

KP pressure controls are available in IP30, IP44 and IP55 enclosures.

Features

- Ultra-short bounce time thanks to snap-action function (reduces wear to a minimum and increases reliability)
- Manual trip function (electrical contact function can be tested without the use of tools)
- KP 6, KP 7 and KP 17 with fail-safe double bellows element
- Vibration and shock resistant
- Compact design
- Fully welded bellows element
- High reliability both electrically and mechanically

Approvals

CE-marked in accordance with:
 – LVD 2006/95/EC
 (EN 60947-1, EN 60947-4-1, EN 60947-5-1)
 – PED 97/23/EC, category IV (EN 12263):
 KP 1, KP 2, KP 6, KP 7 and KP 17

Underwriters Laboratories Inc., UL listed
 China Compulsory Certificate, CCC

Ship approvals

Germanischer Lloyd, GL
 Det Norske Veritas, Norway, DNV
 Registro Italiano Navale, RINA

Bureau Veritas, BV
 Lloyd's Register, LR
 Russian Maritime Register of Shipping, RMRS

Technical data

Ambient temperature		-40 – 65 °C (80 °C for max. 2 hours).
Ambient temperature (PED approved units)		-25 – 65 °C (80 °C for max. 2 hours).
Max. working pressure		LP: PS/MWP = 17 bar
		HP: PS/MWP = 35 bar
		KP 6: PS/MWP = 46.5 bar
Max. test pressure		LP: Pe = 20 bar
		HP: Pe = 35 bar
		KP 6: Pe = 46.5 bar
Contact load	Alternating current	AC1 = 16 A, 400 V AC3 = 16 A, 400 V AC15 = 10 A, 400 V
	Direct current	DC13 = 12 W, 220 V control current
Wire dimensions	solid / stranded	0.75 – 2.5 mm ²
	flexible, without ferrules	0.7 – 2.5 mm ²
	flexible, with ferrules	0.5 – 1.5 mm ²
Tightening torque		max. 2 Nm
Rated impulse voltage		4 kV
Pollution degree		3
Short circuit protection, fuse		16 A
Insulation		400 V
Enclosure		IP30 / IP44 / IP55

Contact systems

Low pressure (LP)		High pressure (HP)			
Dual pressure (LP/HP)		Dual pressure (LP/HP)		Dual pressure (HP/HP)	
<p>SPDT+LP signal</p>		<p>SPDT+LP+HP signal</p>		<p>SPST</p>	

Technical data
(continued)

Cable connection

The cable entry can be used for 6 – 14 mm dia. cables. A Pg 13.5 screwed cable entry can also be used for 6 – 14 mm cable. With 8 – 16 mm cable a standard Pg 16 screwed cable entry can be used.

Enclosure

IP30 to EN 60529 / IEC 60529

Enclosure IP30 is obtained when the units without top cover are mounted on a flat surface or bracket. The bracket must be fixed to the unit so that all unused holes are covered.

IP44 to EN 60529 / IEC 60529

Enclosure IP44 is obtained when the units with top cover are mounted on a flat surface or bracket. The bracket must be fixed to the unit so that all unused holes are covered.

KP pressure controls with auto reset are supplied with top cover. For KP pressure controls with manual reset, the top cover must be separately ordered (**code no. 060-109766** for single pressure controls and **code no. 060-109866** for dual pressure controls).

IP55 to EN 60529 / IEC 60529

IP55 is obtained when the KP pressure controls are mounted in an IP55 enclosure, (**code no. 060-033066** for single pressure controls and **code no. 060-035066** for dual pressure controls).

IP55 enclosure has to be ordered separately.

Materials in contact with the medium

Type	Material
KP 1, KP 2, KP 5, KP 6, KP 7, KP 15 and KP 17	Tinbronze, no. CW452K, EN 1652
	Nickel plated free cutting steel, no. 1.0737 / 1.0718, EN 10277
KP 1A, KP 5A, KP 6, KP 7A and KP 15A only	Stainless steel 18/8, no. 1.4306, EN 10088-2
	Free cutting steel, no. 1.0737, EN 10277
	Cold forming steel, no. 1.0338, EN 10139
	Steel, no 1.0308, EN 10305
	Free cutting steel, no. 1.0715, EN10277
	Free cutting steel, no. 1.0718, EN 10277
	Aluminium, no. AW-3005, EN 573

Ordering

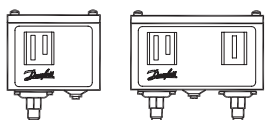

For HCFC and non-flammable HFC refrigerants

Pressure	Type	Low pressure (LP)		High pressure (HP)		Reset		Contact system	Code no.		
		Regulating range [bar]	Differential Δp [bar]	Regulating range [bar]	Differential Δp [bar]	Low pressure LP	High pressure HP		Connection		
									1/4 in. 6 mm flare	1/4 in. ODF solder	6 mm ODF solder
Low	KP 1	-0.2 – 7.5	0.7 – 4.0	—	—	Auto	—	SPDT	060-110166 ³⁾	060-111266 ³⁾	060-111066 ³⁾
Low	KP 1	-0.2 – 7.5	0.7 – 4.0	—	—	Auto	—	SPDT	060-114166 ¹⁾³⁾	—	—
Low	KP 1	-0.9 – 7.0	0.7	—	—	Man. (Min.)	—	SPDT	060-110366	060-111166	060-110966
Low	KP 2	-0.2 – 5.0	0.4 – 1.5	—	—	Auto	—	SPDT	060-112066 ³⁾	—	060-112366 ³⁾
High	KP 5	—	—	8 – 32	1.8 – 6.0	—	Auto	SPDT	060-117166 ³⁾	060-117966 ³⁾	060-117766 ³⁾
High	KP 5	—	—	8 – 32	3	—	Man. (Max.)	SPDT	060-117366	060-118066	060-117866
Dual	KP 15	-0.2 – 7.5	0.7 – 4.0	8 – 32	4	Auto	Auto	SPDT + LP signal	060-124166 ³⁾	060-125466 ³⁾	—
Dual	KP 15	-0.2 – 7.5	0.7 – 4.0	8 – 32	4	Auto	Man. (Max.)	SPDT + LP signal	060-124366	—	—
Dual	KP 15	-0.2 – 7.5	0.7 – 4.0	8 – 32	4	Auto	Man. (Max.)	SPDT + LP signal	060-114866 ¹⁾	—	—
Dual	KP 15	-0.9 – 7.0	0.7	8 – 32	4	Man. (Min.)	Man. (Max.)	SPDT + LP signal	060-124566	—	—
Dual	KP 15	-0.9 – 7.0	0.7	8 – 32	4	Conv. ²⁾	Conv. ²⁾	SPDT + LP signal	060-126166	—	—
Dual	KP 15	-0.2 – 7.5	0.7 – 4.0	8 – 32	4	Auto	Auto	SPDT + LP and HP signal	060-126566 ³⁾	060-129966 ³⁾	—
Dual	KP 15	-0.2 – 7.5	0.7 – 4.0	8 – 32	4	Auto	Man. (Max.)	SPDT + LP and HP signal	060-126466	060-128466	—
Dual	KP 15	-0.2 – 7.5	0.7 – 4.0	8 – 32	4	Conv. ²⁾	Conv. ²⁾	SPDT + LP and HP signal	060-115466 ³⁾	060-001066 ³⁾	—
Dual	KP 15	-0.9 – 7.0	0.7	8 – 32	4	Conv. ²⁾	Conv. ²⁾	SPDT + LP and HP signal	060-122066	—	—

For R717, HCFC and non-flammable HFC refrigerants

Pressure	Type	Low pressure (LP)		High pressure (HP)		Reset		Contact system	Code no.	
		Regulating range [bar]	Differential Δp [bar]	Regulating range [bar]	Differential Δp [bar]	Low pressure LP	High pressure HP		Connection	
									M10 × 0.75	1 m cap. tube with M10 × 0.75
Low	KP 1A	-0.2 – 7.5	0.7 – 4.0	—	—	Auto	—	SPDT	060-116266	060-116066 ³⁾
Low	KP 1A	-0.9 – 7.0	0.7	—	—	Man. (Min.)	—	SPDT	—	060-116166
High	KP 5A	—	—	8 – 32	1.8 – 6.0	—	Auto	SPDT	—	060-123066 ³⁾
High	KP 5A	—	—	8 – 32	3	—	Man. (Max.)	SPDT	060-115366	060-123166
Dual	KP 15A	-0.2 – 7.5	0.7 – 4.0	8 – 32	4	Auto	Auto	SPDT + LP and HP signal	060-129566	060-129366 ³⁾
Dual	KP 15A	-0.2 – 7.5	0.7 – 4.0	8 – 32	4	Auto	Man. (Max.)	SPDT + LP and HP signal	060-129666	060-129466
Dual	KP 15A	-0.9 – 7.0	0.7	8 – 32	4	Conv. ²⁾	Conv. ²⁾	SPDT + LP signal	—	060-128366

¹⁾ Pressure controls with gold-plated contacts

²⁾ Conv.: optional automatic or manual reset

³⁾ Enclosure IP44

Pressure controls PED 97/23/EC approved; EN 12263

For HCFC and non-flammable HFC refrigerants

Pressure	Type ¹⁾	Low pressure (LP)		High pressure (HP)		Reset		Contact system	Code no.	
		Regulating range [bar]	Differential Δp [bar]	Regulating range [bar]	Differential Δp [bar]	Low pressure LP	High pressure HP		Connection	
									1/4 in. 6 mm flare	6 mm ODF solder
Low	KP 1	-0.2 – 7.5	0.7 – 4.0	—	—	Auto	—	SPDT	060-110166 ²⁾	060-111066 ²⁾
Low	KP 1	-0.9 – 7	0.7	—	—	Man. (Min.)	—	SPDT	060-110366	060-110966
Low	KP 2	-0.2 – 5	0.4 – 1.5	—	—	Auto	—	SPDT	060-112066 ²⁾	060-112366 ²⁾
High	KP 6W	—	—	8 – 42	4 – 10	—	Auto	SPDT	060-519066 ²⁾	—
High	KP 6B	—	—	8 – 42	4	—	Man. (Max.)	SPDT	060-519166	—
High	KP 7W	—	—	8 – 32	4 – 10	—	Auto	SPDT	060-119066 ²⁾	060-120366 ²⁾
High	KP 7B	—	—	8 – 32	4	—	Man. (Max.)	SPDT	060-119166	—
High	KP 7S	—	—	8 – 32	4	—	Man. (Max.)	SPDT	060-119266 ²⁾	—
Dual	KP 7BS	—	—	8 – 32	4	—	Man. (Max.) Man. (Max.)	SPST	060-120066	—
Dual	KP 17W	-0.2 – 7.5	0.7 – 4	8 – 32	4	Auto	Auto	SPDT + LP and HP signal	060-127566 ²⁾	060-127666 ²⁾
Dual	KP 17W	-0.2 – 7.5	0.7 – 4	8 – 32	4	Auto	Auto	SPDT+ LP signal	060-126766 ²⁾	—
Dual	KP 17B	-0.2 – 7.5	0.7 – 4	8 – 32	4	Auto	Man. (Max.)	SPDT	060-126866	060-127466
Dual	KP 17WB	-0.2 – 7.5	0.7 – 4	8 – 32	4	Auto	Conv. ⁴⁾	SPDT + LP and HP signal	060-539766 ²⁾³⁾	—

For R717, HCFC and non-flammable HFC refrigerants

Pressure	Type	Low pressure (LP)		High pressure (HP)		Reset		Contact system	Code no.	
		Regulating range [bar]	Differential Δp [bar]	Regulating range [bar]	Differential Δp [bar]	Low pressure LP	High pressure HP		Connection	
									M10 × 0.75	1 m cap. tube with M10 × 0.75
Low	KP 1A	-0.2 – 7.5	0.7 – 4.0	—	—	Auto	—	SPDT	060-116266	060-116066 ²⁾
Low	KP 1A	0.9 – 7	Fixed 0.7	—	—	Man. (Min.)	—	SPDT	—	060-116166
Dual	KP 7ABS	—	—	8 – 32	Fixed 4	Man. (Max.)	Man. (Max.)	SPST	—	060-120566

¹⁾ W = PSH (pressure control), B = PZH (pressure control with ext. reset), S = PZHH (pressure control with int. reset)

²⁾ Enclosure IP44

³⁾ Factory setting: LP side: Range 1 bar Pe, Diff. 1 bar; HP side: Range 18 bar Pe, Diff. 4 bar fixed

⁴⁾ Conv.: optional automatic or manual reset

Pressure control setting with convertible reset

Low pressure	Manual reset ¹⁾	Automatic reset	Automatic reset	Manual reset
High pressure	Manual reset ¹⁾	Manual reset	Automatic reset	Automatic reset

¹⁾ Factory setting

Design / Function

Pressure control, type KP

KP 1, KP 2, KP 5

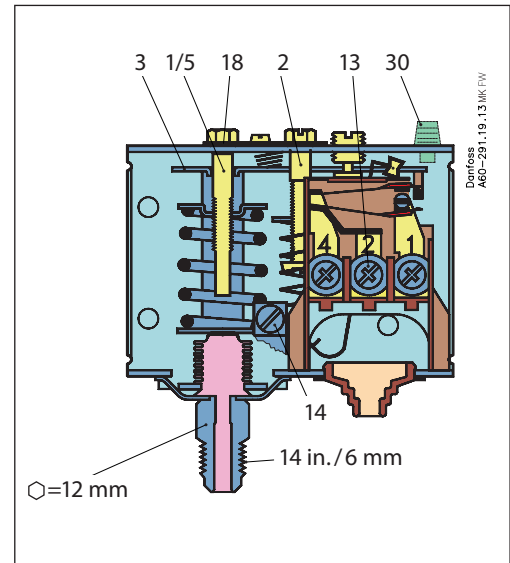
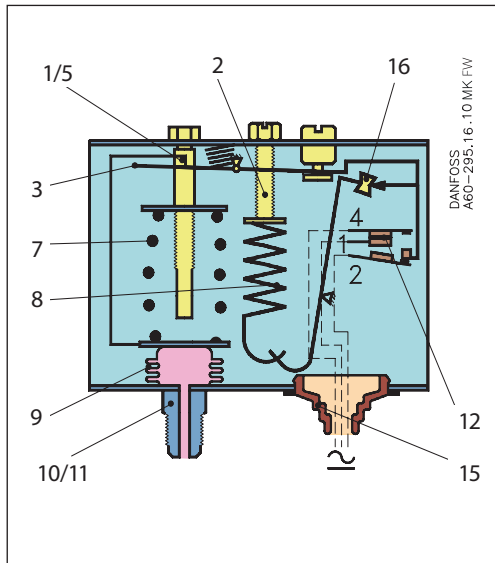

KP 15

Capillary tube for KP 1A, KP 5A and KP 15A

1. Low pressure (LP) setting spindle
2. Differential setting spindle, (LP)
3. Main arm
5. High pressure (HP) setting spindle
7. Main spring
8. Differential spring
9. Bellows
10. LP connection
11. HP connection
12. Switch
13. Terminals
14. Earth terminal
15. Cable entry
16. Tumbler
18. Locking plate
30. Reset button

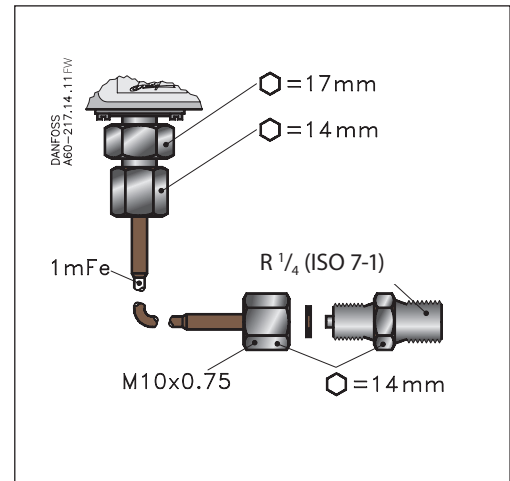
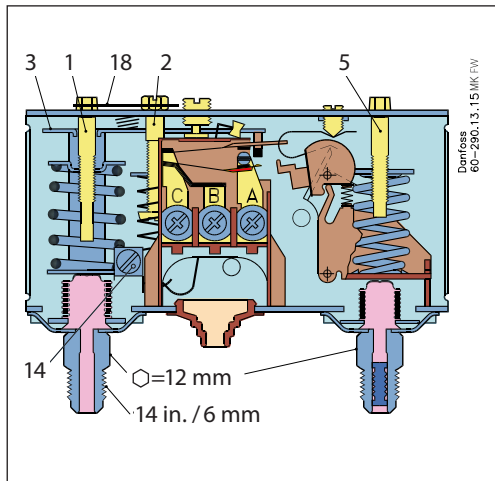

The switch in the KP has a snap-action function and the bellows moves only when the cut-in or cut-out value is reached.

The bellows becomes connected to the low or high pressure side of the plant through connection (10) or (11).

The design of the KP pressure control gives the following advantages:

- high contact load
- ultra-short bounce time
- high resistance to pulsation
- vibration resistance up to 4 g in the range 0 – 1000 Hz
- long mechanical and electrical life

Design
(continued)

KP 7W, flare

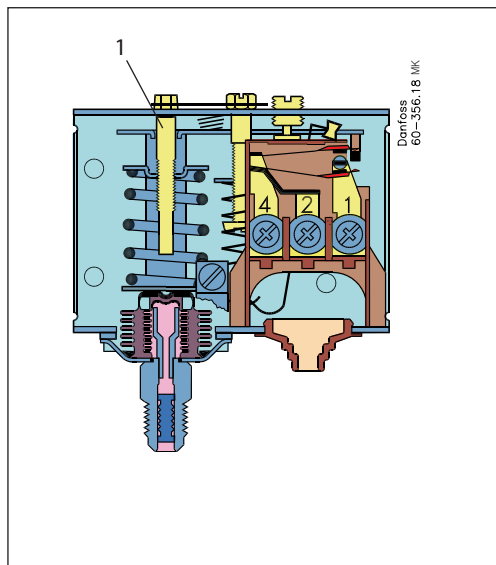

KP 7W, solder

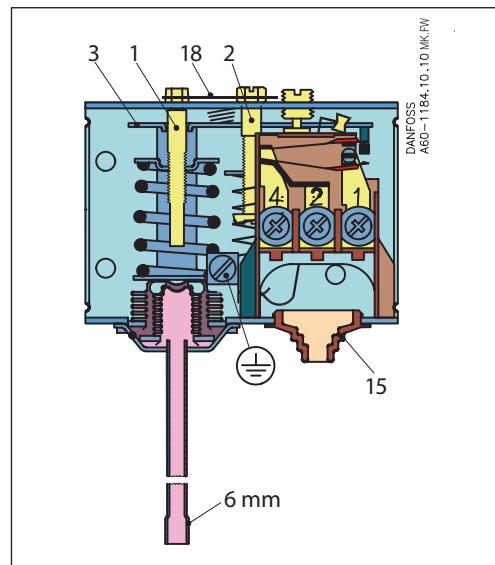

KP 7BS

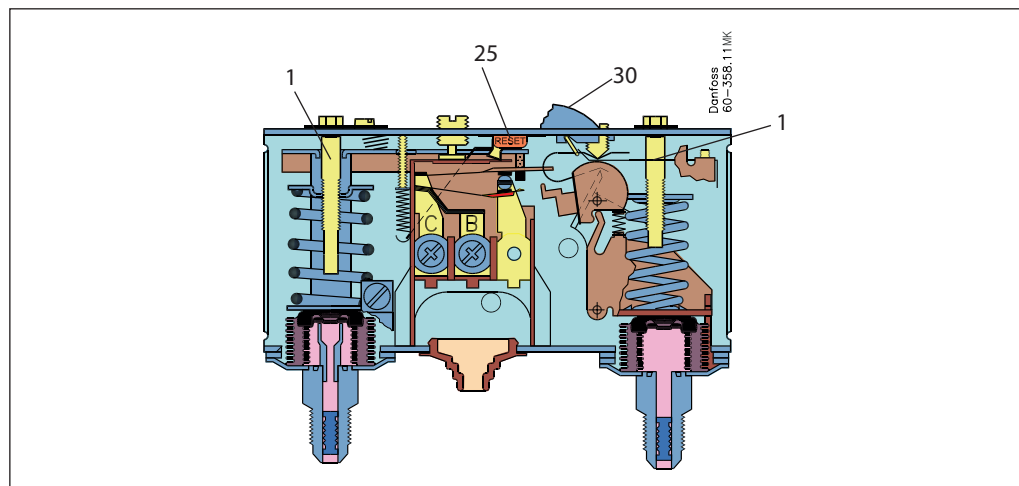

- 1. Pressure setting spindle
- 2. Differential setting spindle
- 3. Main arm
- 15. Cable entry
- 18. Locking plate
- 25. Int. reset arm
- 30. Ext. reset button

KP1, KP1A, KP2, KP6, KP6A, KP7 and KP17 units with designation W, B or S have been tested and approved by TÜV, Rheinland in accordance with EN 12263.

KP6, KP6A, KP7 and KP17 have a double bellows: an outer bellows and a regulating bellows. When system pressure exceeds the set value, the KP will automatically stop the plant. The double bellows system prevents loss of charge in the event of bellows rupture.

A rupture in the inner bellows will cause the control cut-out pressure to fall about 3 times less the set value, thus the refrigeration plant compressor will stop.

A rupture in the outer bellows will cause the control cut-out pressure to fall to about 3 bar under the set value, thus providing a fail-safe function.

Versions with designation W or AW cut in again automatically when the pressure has fallen to the set value minus the differential.

Versions with designation B or AB can be cut in manually with the external reset button when the pressure in KP1 has increased 0.7 bar above set value and in KP6 and KP7 has fallen 4 bar under the set value.

Versions with designation S or AS can be cut in manually with the internal reset arm when the pressure has fallen 4 bar under the set value.

All KP pressure controls, including those which are PED-approved, operate independently of changes in the ambient temperature around the control housing. Therefore the set cut-out pressure and differential are held constant provided the permissible ambient temperatures are not exceeded.

Terminology

Reset

1. Manual (Min./Max.) reset:
Units with manual reset can only be reset during operation by activation of the reset button.
2. Automatic reset:
After operational stop, these units reset automatically.
3. Convertible reset:
Units with optional reset can be activated by automatic and/or manual reset.

Permissible working pressure

The permissible working pressure is determined by the pressure that can be safely allowed in the refrigerating system or any of the units within it.

Test pressure

The test pressure is the pressure used in strength tests and/or leakage tests on refrigerating systems or individual parts in systems. The test pressure is designated P_e .

"Snap function"

A certain contact force is maintained until irrevocable "snap" is initiated. The time during which the contact force approaches zero is thus limited to a very few milliseconds. Therefore contact bounce cannot occur as a result of, for example, slight vibrations, before the cut-out point. Contact systems with "Snap function" will change over even when micro-welds are created between the contacts during cut-in. A very high force is created during cut-out to separate the contacts. This force immediately shears off all the welds. Thus the cut-out point of the unit remains very accurate and completely independent of the magnitude of the current load.

Setting

Pressure controls with automatic reset – LP:

Set the LP start pressure on the "CUT-IN" scale (range scale). One rotation of the low pressure spindle ~ 0.7 bar. Set the LP differential on the "DIFF" scale. One rotation of the differential spindle ~ 0.15 bar. The LP stop pressure is the LP start pressure minus the differential.

Note:

The LP stop pressure must be above absolute vacuum ($p_e = -1$ bar)!

If with low stop pressure the refrigeration compressor will not stop, check to ensure that the differential value has not been set too high!

Pressure controls with automatic reset – HP:

Set the HP pressure on the "CUT-OUT" scale. One rotation of the HP spindle ~ 2.3 bar. Set the HP differential on the "DIFF" scale. One rotation of the differential spindle ~ 0.3 bar. The HP start pressure is the HP stop pressure minus the differential.

Start and stop pressures for both the LP and HP sides of the system should always be checked with an accurate pressure gauge.

Pressure controls with manual reset

Set the stop pressure on "CUT-OUT" scale (range scale).
Low pressure controls can be manually reset when the pressure is equal to the stop pressure plus the differential.
High pressure controls can be manually reset when the pressure is equal to the stop pressure minus the differential.

Dimensions [mm] and weights [kg]

Pressure controls with flare connection

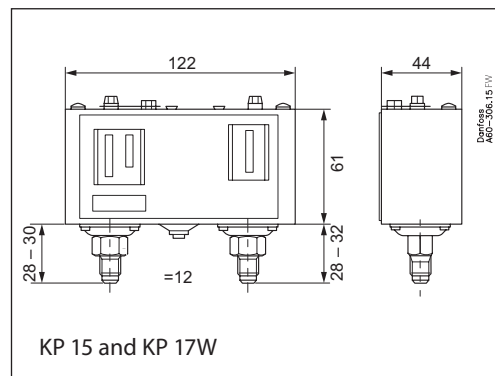
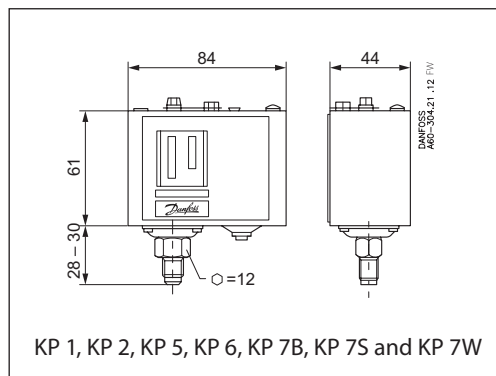

M10 x 0.75 connection

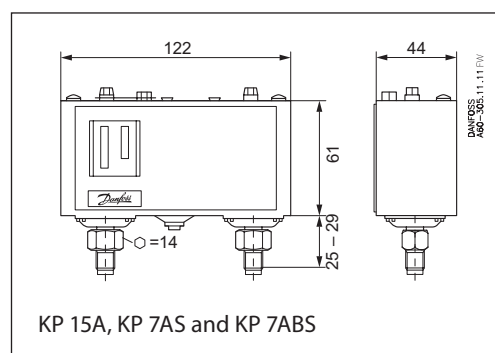
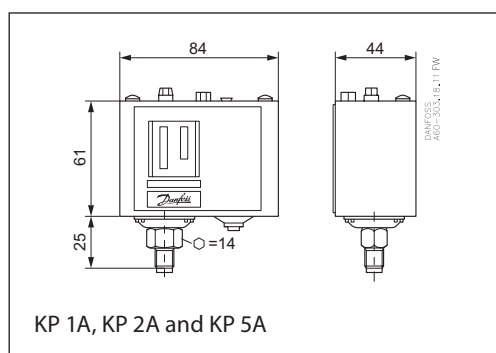

Solder connection

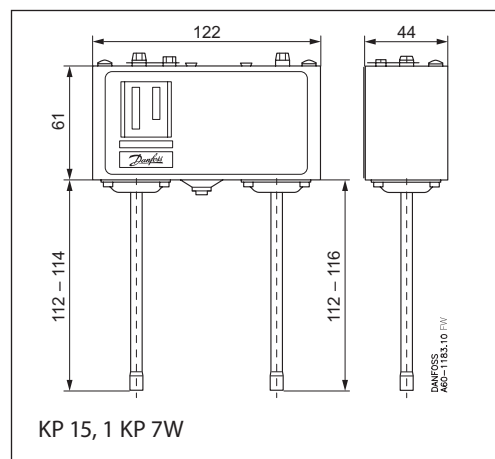
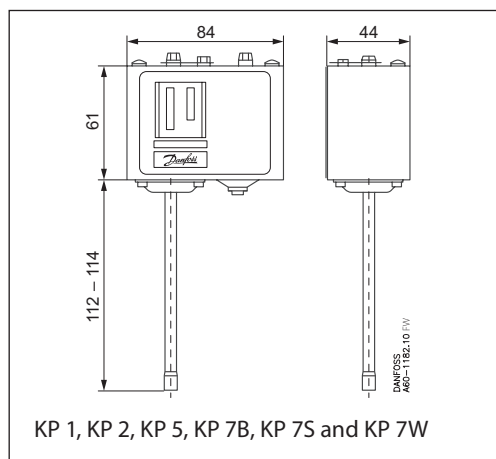

KP with top cover

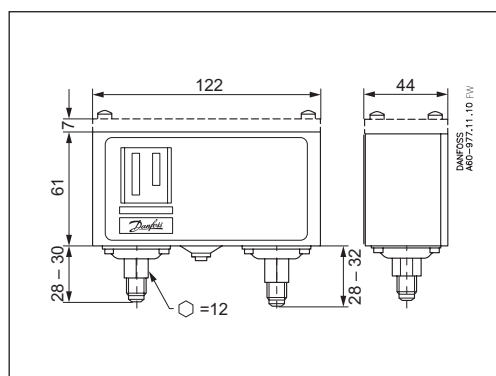

Net weight:
 KP 1, KP 2, KP 5 and KP 7: approx. 0.3 kg
 KP 15, KP 17 and KP 7BS: approx. 0.5 kg
 KP 1A and KP 5A: approx. 0.3 kg
 KP 15A and KP 7ABS: approx. 0.5 kg

**Dimensions [mm]
and weights [kg]**
(continued)

IP55 enclosure

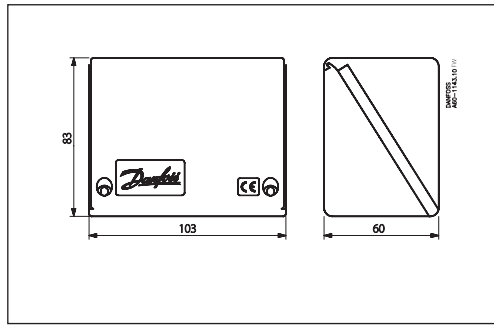

IP55 enclosure for dual types

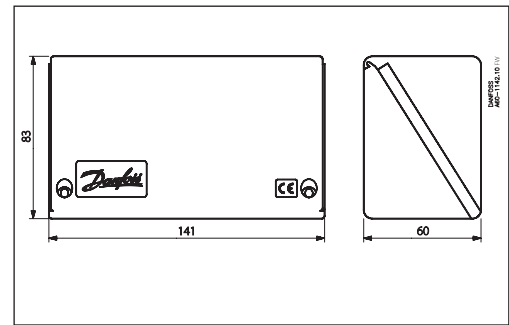

Weld nipple for KP-A

