



Technical brochure

Oil regulating valve

ORV 25-80 (1-3 in.)



ORV are 3-way industrial valves for maintaining a constant oil temperature in gas compressor systems, by mixing hot and cold oil in the lubricating system of e.g. screw or turbo type compressors.

The ORV valves are with few components and with extended cylindrical connections, to ensure ease of installation and service.

The thermostatic element has a built-in temperature setting of 49°C (120°F) as standard. For other temperatures please see page 10.

Features

- Stainless steel nickel plated thermostatic element.
- Butt-weld (DIN, ANSI) or socket weld (SOC) connection.
- No manual adjustment.
- Plug and Play design.
- Optimised flow characteristics.
- Sturdy construction.
- High resistance against vibrations or shock.
- Can be mounted in any direction.
- Service friendly. Easy to dismantle and service when required.

Technical data

Oils:
Applicable to all common refrigeration oils.

Refrigerants:
Applicable to HC, HCFC, HFC, R717 (Ammonia) and R744 (CO₂).
For further information please refer to installation instruction for ORV.

Temperature range:
Minimum operating temperature:
≥ -10°C (+14°F)

Max. temperature limit based on the element temperature settings:

Types	Max limit
43°C / 110°F	76.66°C / 170°F
49°C / 120°F	82.22°C / 180°F
54°C / 130°F	87.77°C / 190°F
77°C / 170°F	110°C / 230°F

Pressure range:
The valves are designed for a max. working pressure of 40 bar g (580 psig)

Oil regulating valve, type ORV

Design

Connections

Available with the following connections:

- Butt weld DIN (EN 10220),
– DN 25-80 (1-3 in.)
- Butt weld ANSI (B 36.10 Schedule 80),
– DN 25 - 40 (1 - 1½ in.)
- Butt weld ANSI (B 36.10 Schedule 40),
– DN 50 - 80 (2 - 3 in.)
- Socket Weld (ANSI B 16.11),
– DN 25 - 50 (1 - 2 in.)

Housing

Made of special, cold resistant steel approved for low temperature operations.

Installation

Installation of the valve depends on the way it should operate.

Pressure Equipment Directive (PED)

ORV valves are approved according to the European standard specified in the Pressure Equipment Directive and are CE marked. For further details / restrictions - see Installation Instruction.



Identification

Example:

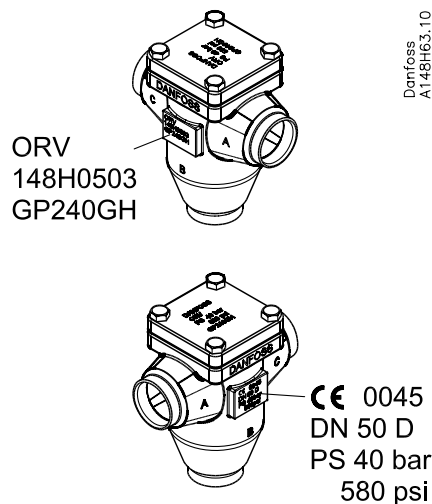

Function

Mixing operation

ORV valve can work as a mixing or diverting valve. The ORV oil regulating valve utilises the high coefficient of thermal expansion of wax to create the internal movement necessary to have a cold and a hot inlet mixing to a common outlet. The outlet temperature will correspond to the nominal temperature of the thermostatic element.

The valve house has three ports:

- Port A is used for the common outlet
- Port B is for the hot inlet
- Port C is for the cold inlet

When the compressor unit is cold at start up, the thermostatic element will be contracted to let the full flow from port B pass until the nominal temperature (minus 5 K / 10°F) is reached (fig. 1.1). The thermostatic element will then begin to extract to let the outlet become a mixture of hot and cold oil.

When the nominal temperature is reached, the element is positioned in approximately half open position (fig. 1.2). If the temperature is reaching approximately the nominal temperature plus 5 K, the thermostatic element has been extracted to its fully open position (fig. 1.3). In this position the oil temperature will only come from the cold inlet port (C) from oil cooler.

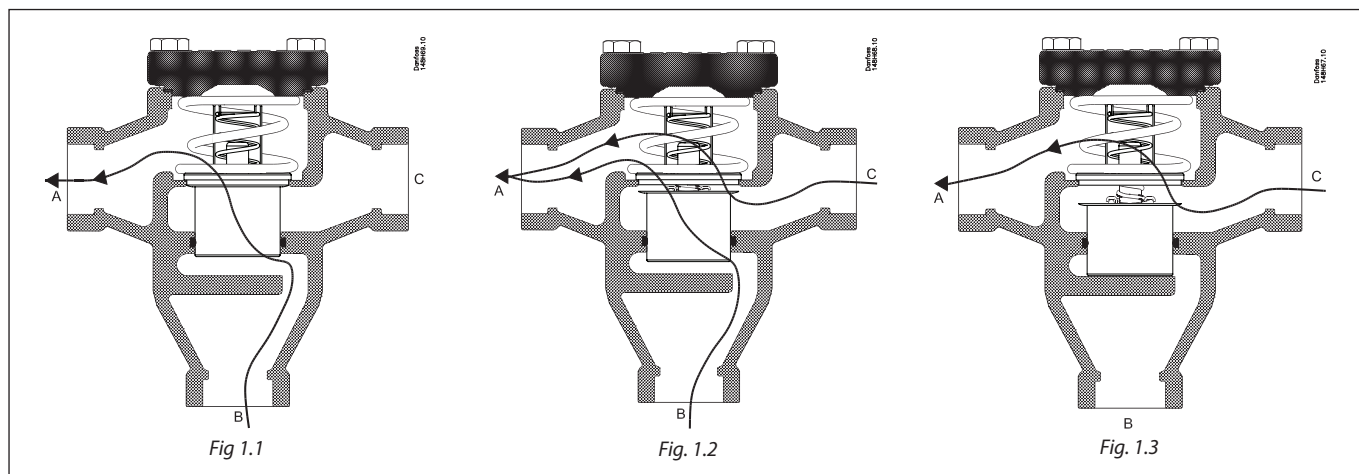

From figure 1, it can be seen how the sleeve on the element is sliding in a vertical movement. The thermostatic element is kept in position by a spring.

Oil regulating valve, type ORV

Function (continued)

Diverting operation

Diverting operation is similar to the mixing operation. It is carried out with separation in to two of the fluid with single temperature. Due to that the temperature on the inlet is very stable fact the regulation is very smooth. The inlet temperature would correspond to the nominal temperature of the thermostatic element.

The valve house has three ports:

- Port A is used for the common inlet
- Port B is for the cold outlet
- Port C is for the warm outlet

The diverting operation otherwise is similar to the mixing operation.

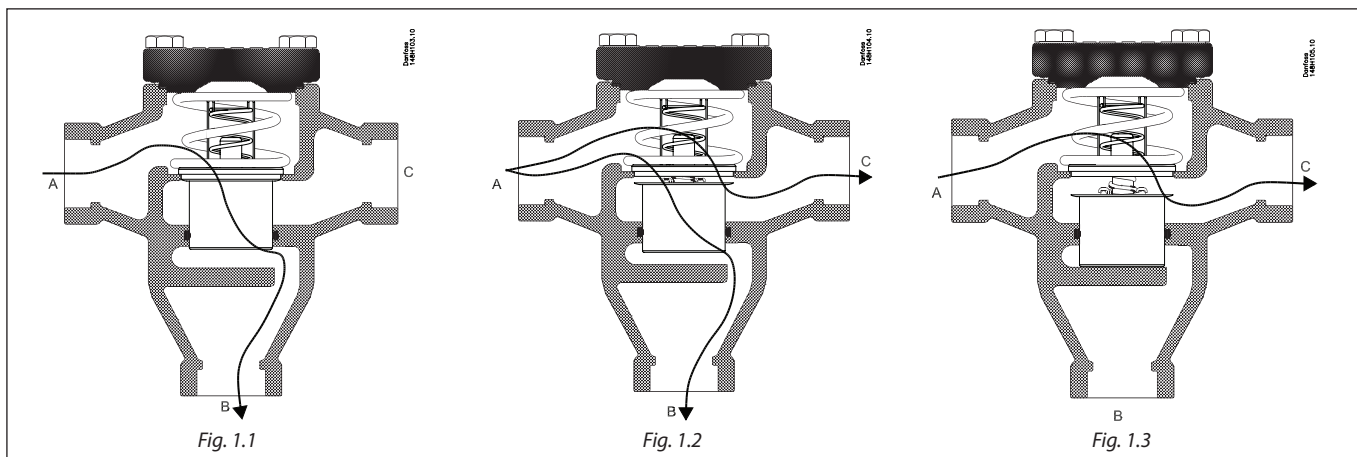

Oil regulating valve, type ORV

Application examples

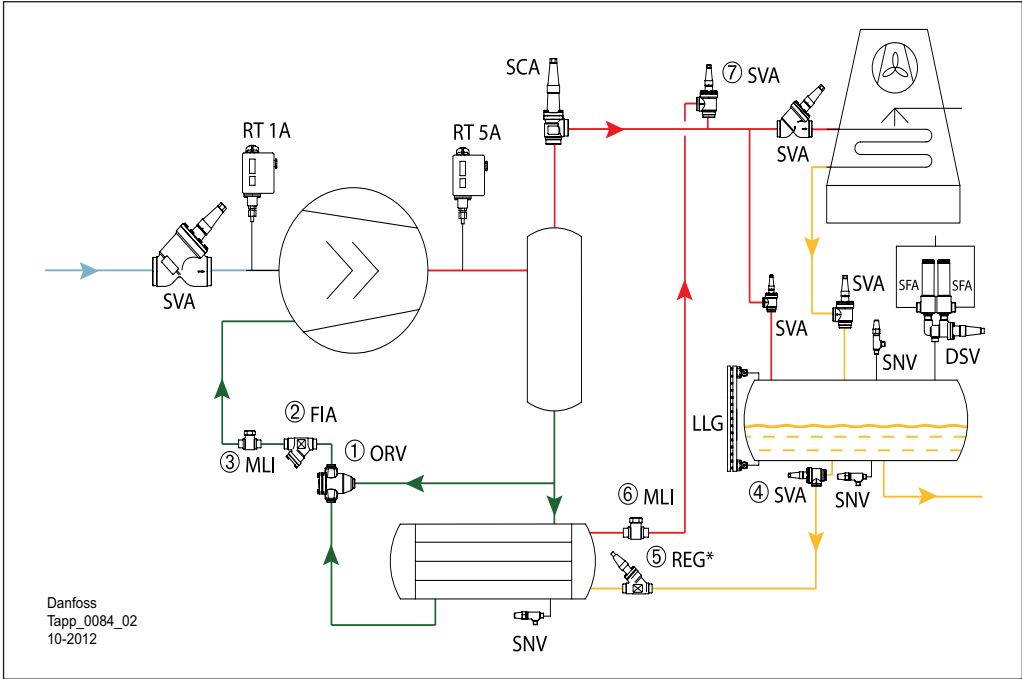

Example of the system with ORV for mixing operation.

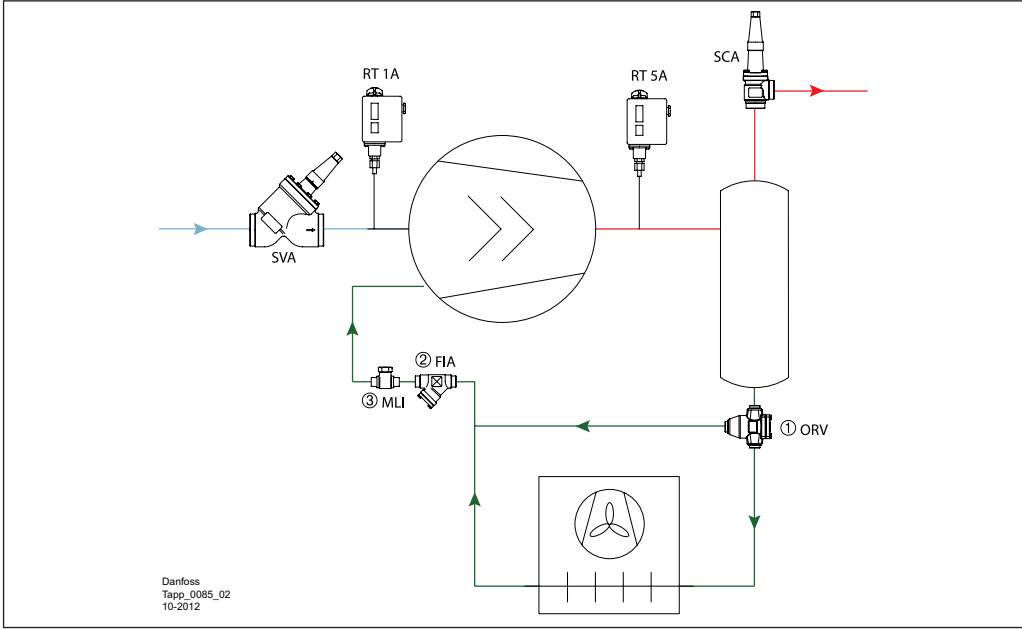

Example of the system with ORV for diverting operation

Oil regulating valve, type ORV

Capacities
SI units

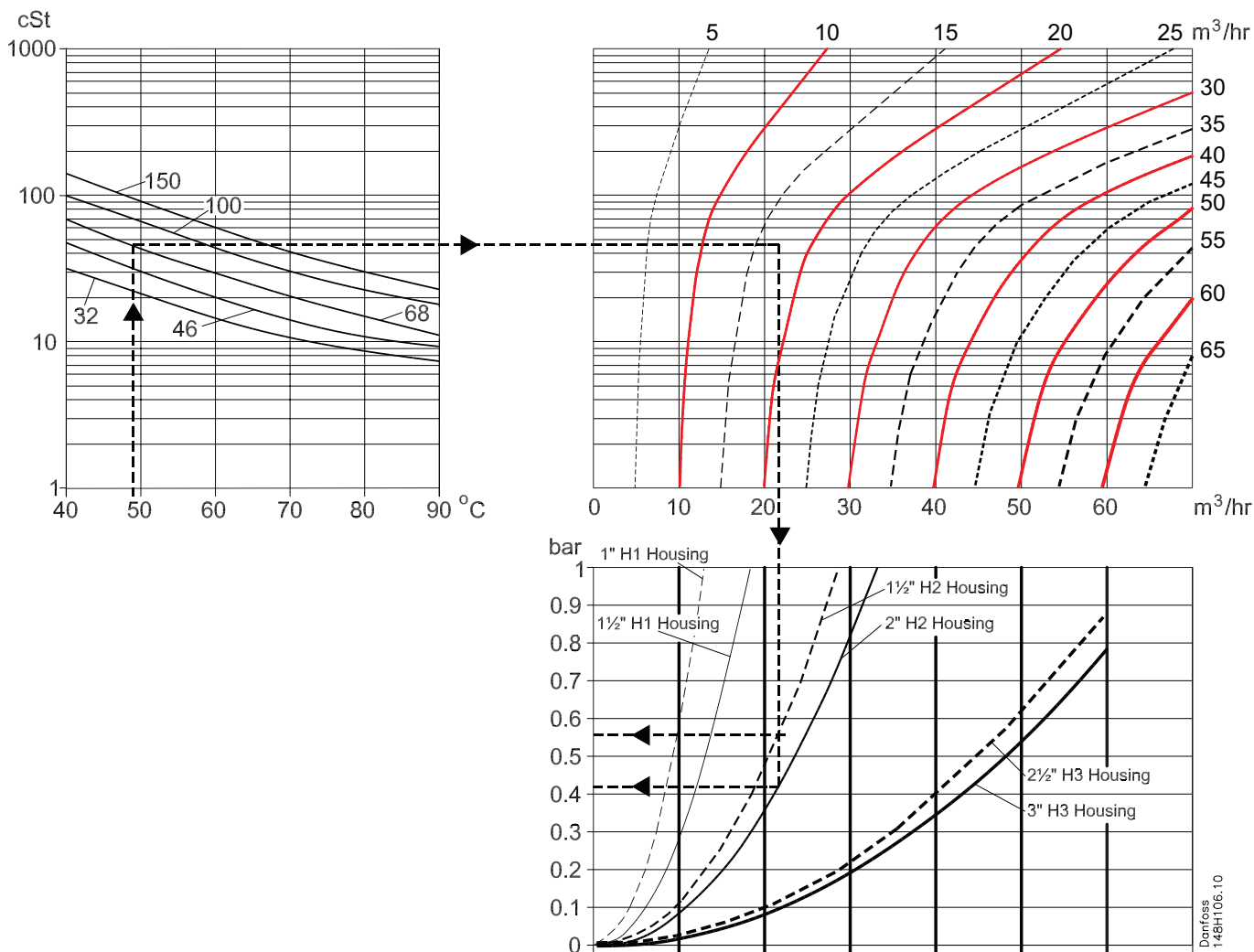

Selection example

Oil type: Grade 68
 Required flow: 17 m³/h
 Nominal oil temperature: 49°C
 Pipe dimension: 40 mm

The upper left curve shows the viscosity of different grades of oil as a function of the temperature. The viscosity is continued into the upper right curve where the 17 m³/h must be found. The line is drawn vertically downwards into the capacity table for the ORV valve models.

As shown two selections can be made:

Either ORV 40 H2 with pressure drop at approx. 0.56 bar or ORV 50 H2 with pressure drop at 0.42 bar.

The final selection will depend on the available pressures in the system. If the pressures are low (or can be low at certain loads) the ORV 50 H2 might be preferred. If the pressures are constantly available the pipe dimension may be taken into account and the ORV 40 H2 might be preferred.

Capacities
US units

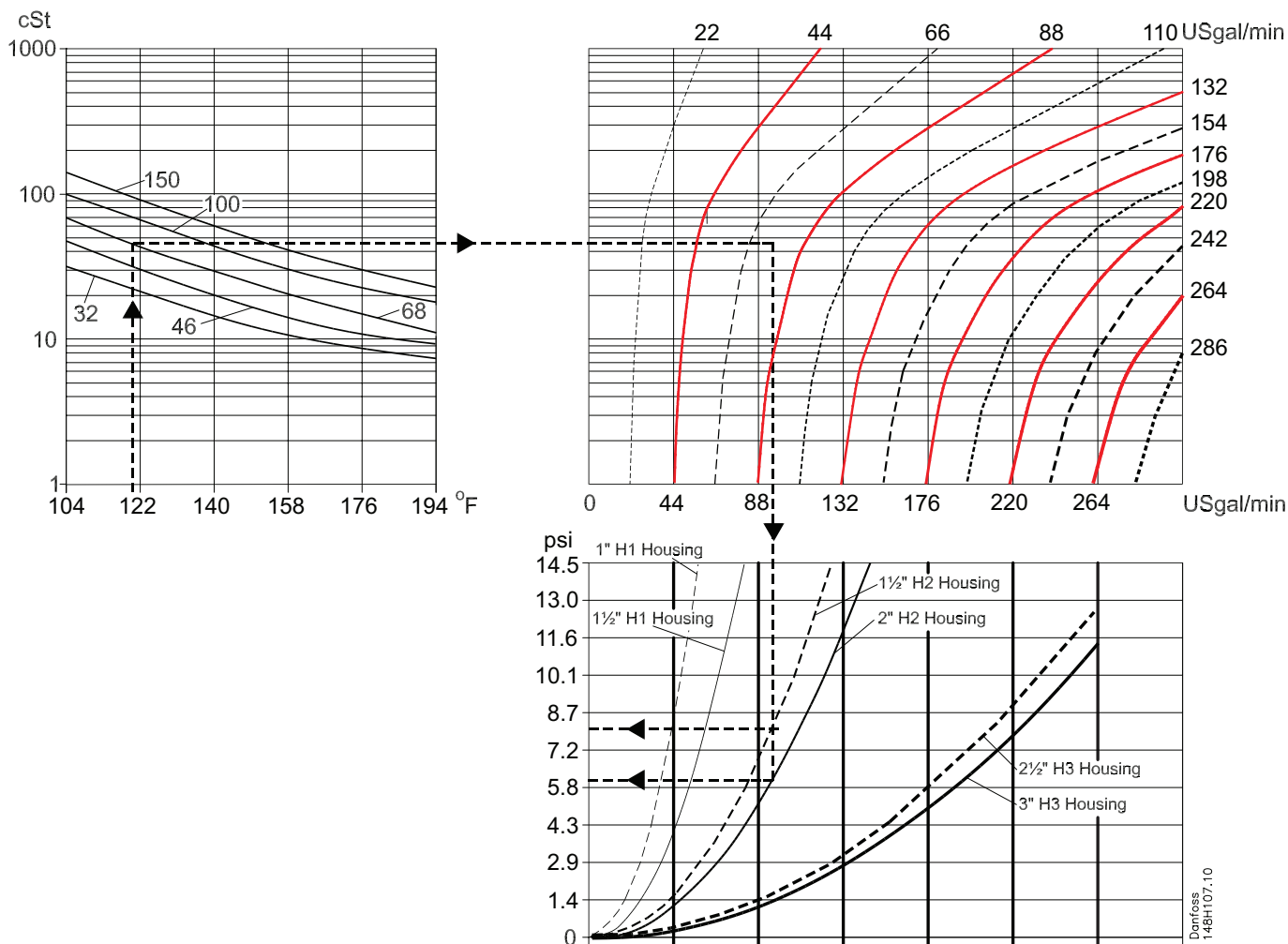

Selection example

Oil type: Grade 68
 Required flow: 75 USgal/min.
 Nominal oil temperature: 120°F
 Pipe dimension: 1 1/2"

The upper left curve shows the viscosity of different grades of oil as a function of the temperature. The viscosity is continued into the upper right curve where the 75 USgal/min. must be found. The line is drawn vertically downwards into the capacity table for the ORV valve models.

As shown two selections can be made:

- Either
- ORV 1 1/2"H2 with pressure drop 8.2 psi or
- ORV 2"H2 with pressure drop 6.2 psi

The final selection will depend on the available pressures in the system. If the pressures are low (or can be low at certain loads) the ORV 2" H2 might be preferred. If the pressures are constantly available the pipe dimension may be taken into account and the ORV 1 1/2" H2 might be preferred.

Oil regulating valve, type ORV

Material specification

ORV 25-80

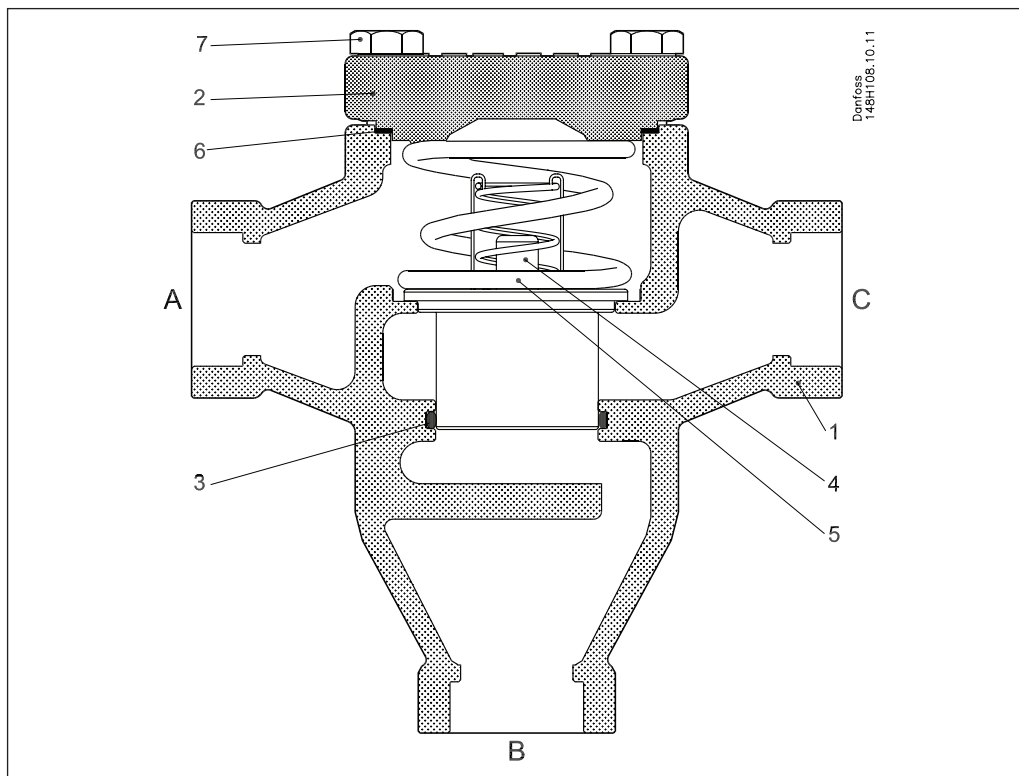

No.	Part	Material	EN		ASTM standard	
1	Housing	Steel	GP240GH	10213-2	WCB	A 216
2	Cover	Steel	GP240GH ----- P285QH	10213-2 ----- 10222-4	WCB	A 216 ----- A 350
3	Glide ring	PTFE				
4	Element ^{*)}	Stainless steel and Ni plated parts				
5	Spring	Steel	DIN17223	10270-1		
6	Gasket	Non asbestos				
7	Bolts	Steel	Quality 8.8	ISO4017	Grade 5	

*) The thermostatic element may look differently from one shown on the picture. All types of thermostats used by Danfoss have the same function, temperature setting and P-band.

Oil regulating valve, type ORV

Connections

DIN

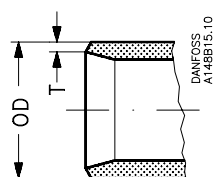

Size mm	Size in	OD mm	T mm	OD in	T in			K _v / C _v H1 housing		K _v / C _v H2 housing		K _v / C _v H3 housing	
								K _v m ³ /h	C _v Usgal/min	K _v m ³ /h	C _v Usgal/min	K _v m ³ /h	C _v Usgal/min
Butt-weld DIN (EN10220)													
25	1	33.7	2.6	1.327	0.103			15	17	-	-	-	-
40	1½	48.3	2.6	1.902	0.103			22	26	30	35	-	-
50	2	60.3	2.9	2.37	0.11			-	-	36	42	-	-
65	2½	76.1	2.9	3	0.11			-	-	-	-	65	75
80	3	88.9	3.2	3.5	0.13			-	-	-	-	75	87

ANSI

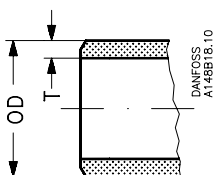

Size mm	Size in	OD mm	T mm	OD in	T in			K _v / C _v H1 housing		K _v / C _v H2 housing		K _v / C _v H3 housing	
								K _v m ³ /h	C _v Usgal/min	K _v m ³ /h	C _v Usgal/min	K _v m ³ /h	C _v Usgal/min
Butt-weld ANSI (B 36.10 Schedule 80)													
25	1	33.7	4.6	1.327	0.181			15	17	-	-	-	-
40	1½	48.3	5.1	1.902	0.201			22	26	30	35	-	-
Butt-weld ANSI (B 36.10 Schedule 40)													
50	2	60.3	3.9	2.37	0.15			-	-	36	42	-	-
65	2½	73	5.2	2.87	0.2			-	-	-	-	65	75
80	3	88.9	5.5	3.5	0.22			-	-	-	-	75	87

SOC

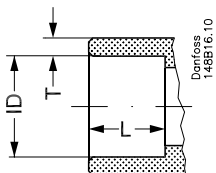

Size mm	Size in	ID mm	T mm	ID in	T in	L mm	L in	K _v / C _v H1 housing		K _v / C _v H2 housing		K _v / C _v H3 housing	
								K _v m ³ /h	C _v Usgal/min	K _v m ³ /h	C _v Usgal/min	K _v m ³ /h	C _v Usgal/min
Socket welding ANSI (B 16.11)													
25	1	33.9	7.2	1.335	0.284	13	0.51	15	17	-	-	-	-
40	1½	48.8	6.6	1.921	0.26	13	0.51	-	-	30	35	-	-
50	2	61.2	6.2	2.41	0.24	16	0.63	-	-	36	42	-	-

Oil regulating valve, type ORV

Dimensions and weights

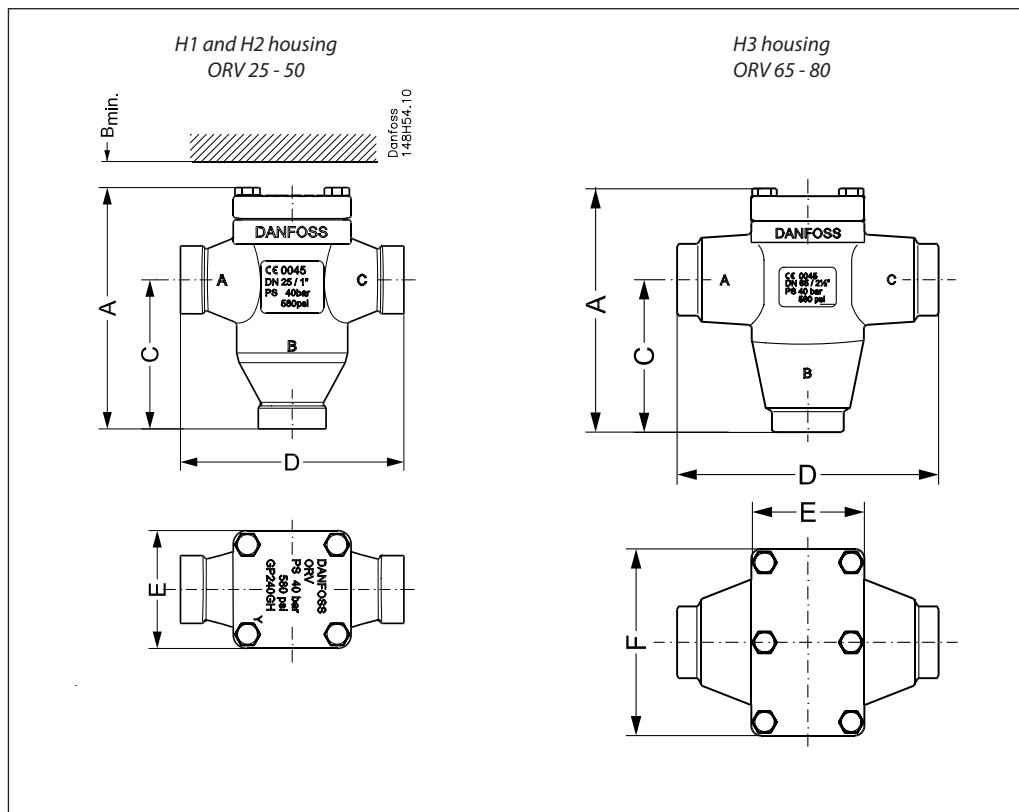

Valve size	Valve size		A	B _{MIN.}	C	D	E	F	Weight
H1 housing	ORV 25-40	mm	178	75	110	165	87	-	4.5 kg
	(1-1½)	in.	7.00	3.00	4.33	6.50	3.43	-	10 lb
H2 housing	ORV 40-50	mm	215	80	138	196	110	-	9.0 kg
	(1½-2)	in.	8.46	3.15	5.43	7.72	4.33	-	20 lb
H3 housing	ORV 65-80	mm	252	80	155	266	115	190	18 kg
	(2½-3)	in.	9.92	3.15	6.10	10.47	4.53	7.48	40 lb

Oil regulating valve, type ORV

Type codes

Valve type	ORV	Oil regulating valve, high specification			
Nominal size in mm (valve size measured on the connection diameter)		Available connections			
		DIN	ANSI	SOC	
	25	X	X	X	
	40	X	X	X	
	50	X	X	X	
	65	X	X		
	80	X	X		
Connection	A D SOC	Butt weld connection: ANSI Butt weld connection: DIN Socket welding			
Valve housing	3-WAY	3-WAY			

Important!

Where products need to be certified according to specific certification societies or where higher pressures are required, the relevant information should be included at the time of ordering.

Ordering ORV valves from the parts programme

Example:

ORV 40 DIN H2 49°C/120°F:

Thermostat element and cover gasket
code number 148H3244

and

Complete valve housing
code number 148H3402



Please note:

The thermostat code numbers do not include guide ring.

Gasket and guide ring are included when ordering the complete valve housing but can also be ordered separately as spare parts (see next page).

ORV parts programme

Thermostat		Code no.
Thermostat 43°C/110°F	ORV 25 and ORV 40 H1	148H3250
	ORV 40 and ORV 50 H2	148H3254
	ORV 65 and ORV 80 H3	148H3393 ¹⁾
Thermostat 49°C/120°F	ORV 25 and ORV 40 H1	148H3243
	ORV 40 and ORV 50 H2	148H3244
	ORV 65 and ORV 80 H3	148H3245 ¹⁾
Thermostat 54°C/130°F	ORV 25 and ORV 40 H1	148H3251
Thermostat 77°C/170°F	ORV 25 and ORV 40 H1	148H3253
	ORV 40 and ORV 50 H2	148H3257
	ORV 65 and ORV 80 H3	148H3456 ¹⁾

Complete valve housing including gasket and guide ring but without thermostat	Code no.
ORV 25 DIN H1	148H3399
ORV 25 SOC H1	148H3400
ORV 25 ANSI H1	148H3401
ORV 40 DIN H1	148H3361
ORV 40 DIN H2	148H3402
ORV 40 SOC H2	148H3403
ORV 40 ANSI H1	148H3404
ORV 40 ANSI H2	148H3405
ORV 50 DIN H2	148H3406
ORV 50 SOC H2	148H3407
ORV 50 ANSI H2	148H3408
ORV 65 DIN H3	148H3409
ORV 65 ANSI H3	148H3410
ORV 80 DIN H3	148H3362
ORV 80 ANSI H3	148H3411

¹⁾ For valve housing size H3 the code number includes two H2 thermostats.

Oil regulating valve, type ORV

Ordering complete factory assembled ORV valves

Example:
ORV 40 DIN H2 49°C/120°F = **148H3230**

Complete factory assembled ORV valves

	43°C / 110°F	49°C / 120°F	54°C / 130°F	77°C / 170°F
25 DIN H1 (1")	148H3320	148H3227	148H3258	148H3322
25 SOC H1 (1")	148H3327	148H3229	148H3328	
25 ANSI H1 (1")	148H3323	148H3228		
40 DIN H1 (1½")	148H3364	148H3241		
40 DIN H2 (1½")	148H3332	148H3230		148H3336
40 SOC H2 (1½")		148H3232		
40 ANSI H1 (1½")		148H3242		
40 ANSI H2 (1½")		148H3231		
50 DIN H2 (2")	148H3342	148H3233		
50 SOC H2 (2")	148H3346	148H3235		
50 ANSI H2 (2")		148H3234		
65 DIN H3 (2½")	148H3351¹⁾	148H3236¹⁾		
65 ANSI H3 (2½")	148H3356¹⁾	148H3237¹⁾		
80 DIN H3 (3")		148H3239¹⁾		
80 ANSI H3 (3")		148H3240¹⁾		

D = Butt-weld DIN
A = Butt-weld ANSI
SOC = Socket welding

¹⁾ For valve housing H3 there are two H2 thermostats and one seal

ORV spare parts

Part	Spare parts for	Code no.
Gasket and guide ring	ORV 25 and ORV 40 H1	148H3246
	ORV 40 and ORV 50 H2	148H3247
	ORV 65 and ORV 80 H3	148H3248²⁾

²⁾ Including two guide rings and one gasket.

