



# AK-SC255

Software Release **VR2.191**

**R Version**

# Contents

3	<b>Preface</b>
4	<b>Getting Started</b>
6	<b>File Management</b>
8	<b>Emergency file generation</b>
10	<b>Device Management</b>
12	<b>Connecting AK-SC255 to an IP (Ethernet) network</b>
14	<b>Network Scan &amp; System Configuration (on-line configuration)</b>
17	<b>Generic Case Controller Configuration</b>
22	<b>Energy Meter Options and configuration</b>
25	<b>Setting up Master Control functions</b>
29	<b>Lighting Control</b>
34	<b>Lighting Panels (Siemens P1 (Modbus))</b>
37	<b>History Configuration</b>
41	<b>Distech EC-Stat HVAC thermostat support</b>
44	<b>Lennox HVAC support</b>
48	<b>Carrier-UPC (Modbus) Interface</b>
54	<b>Com-Trol local bus interface</b>
56	<b>Central Alarm Configuration</b>
62	<b>Daily User</b>
64	<b>Appendix / new functions and features</b>
98	<b>Lighting Panel Square D PowerLink G3 (Modbus)</b>

# Preface

This supplement manual is designed to compliment the already existing **AK-SC255 System Reference Manual (RS.8D.M1.22)** and highlights the latest features in the 'R' version of AK-SC255 software.

In addition further information can be found via;  
**AK Input - Output Modules (DKRCE.PI.R1.A2.22)**  
**AK-SC 255 On site Guide (RS.8C.J2.22)**  
**Data Communication between ADAP-KOOL® Refrigeration Controls (RC8AC302)**  
**AK-SC255 Factsheet (DKRCE.PD.R1.A1.22)**

The latest version of 'R' AK-SC255 software allows for direct support of EKC and AK2 Danfoss case controls and is in addition to the existing rack control method(s). This supplement manual focuses on the new EKC and AK2 case control support (known as Generic in the AK-SC255 system) and highlights the processes required to manage these devices.

To get the best benefit from this supplement manual please ensure you have a good knowledge of the various system menus and features as described in the AK-SC255 system reference manual.

Due to the highly flexible nature of the AK-SC255 product and the multiple configurations it can cover, it is highly recommended that prior to any major commissioning you attend an authorized Danfoss training course to get the most out of your system.

This manual revision supersedes Supplement Manual VR2.181



AK-SC255 Software version 02-081 and above has enhanced alarm handling functionality - Please ensure you read & fully understand this new functionality before performing site installations or upgrades.

Document History	Changes
02_081	New Alarm Actions Modbus Siemens Lighting Panel Support
02_085	Carrier Interface
02_101	Added connecting AK-SC255 to IP network Added Lennox HVAC support Updated loading software (Appendix section)
02_111	Updated store info & Preference screen's
02_121	Added section on Wattnode Pluse Modbus meter Added new Industrial defrost feature (under appendix section) Updated section on rescan network channels
02_151	Added Com-Trol local bus support (AK-SC255 license required) Compressor, Condenser, Heat Reclaim, Exhaust fan control (Kroger applications)
02_153	Re-issue document to maintain code visioning
02_165	Added screen shots to highlighting new features (found under appendix section)
02_172	No changes
02_181	Added Square D PowerLink G3 Modbus lighting panel
02_191	

## Getting Started

The following instructions represent the typical steps needed to get the AK-SC255 up and running. Although not exhaustive this represents the most widely used settings in most typical customer applications.

To assist in the commissioning process not only can the local key pad be used for all tasks, so can the system support software tool - **AKA65**. Utilizing the AKA65 software will allow 'on-line' and 'off line' commissioning. Connection to the AK-SC255 can be made either via serial RS232 or Ethernet.

Connect either via Serial or Ethernet Cat 5 cable



AKA65 Software

Adapter Cable AK2 to PC (080Z0262)

Cat5e Ethernet Cable

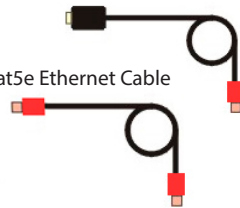

Note that if a straight PC to AK-SC255 connection is made via Ethernet cable it must be a cross over type. If connecting via an Ethernet hub or switch a regular Cat5 cable can be used

The focus of this supplement manual is to describe the common commissioning tasks on EKC and AK2 case controllers. Several new screens have been developed to support these new devices. Rack control is still driven via the AK-SC255 and AK2 I/O modules.

Generic EKC & AK2 case controller support

EKC case network type Lonworks® RS485 or FTT10  
AK2 case network type Lonworks® RS485 or TP78  
EKA 167 display network type Modbus



Traditional Rack, Lighting and HVAC control, via AK2 I/O modules.

Described in the AK-SC255 System Reference Manual (RS.8D.M1.22)

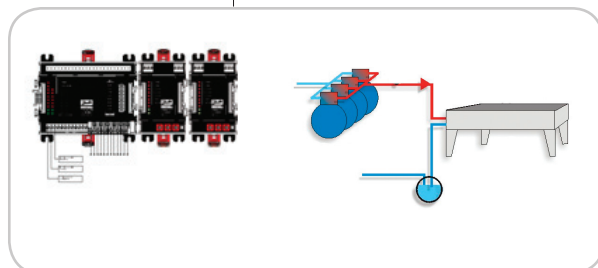
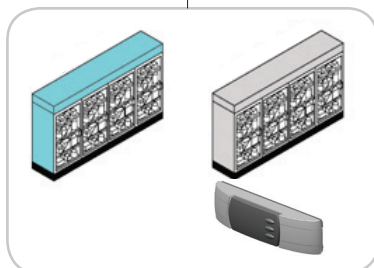

## Configure system settings (Auth codes, Store Name, Time, Date...)

From the 'Main Menu' select '**Store Info**'. This page is used to program the systems time clock, date, unit preferences and other system orientated details. To make changes to the system a suitable level of authorization will be needed. The factory setting authorization code is 12345 Account 50 (Supervisor).



Factory Supervisor Level Authorization codes:

12345  
50

Configure the **Store Name, Store Clock**

Configure the Units/Language, Preferences, Daylight Saving & Opening Hours

### Opening Hours

Used in conjunction with lighting options

Note: 00:00 - 00:00 = always on

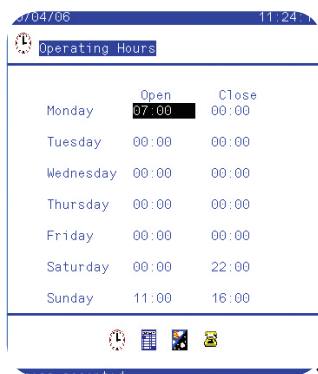

### Unit / Language

Set appropriate Unit & language type(s)

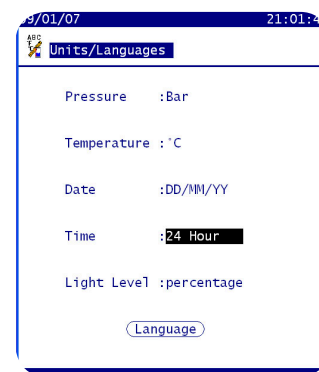

Store Name: provide name  
Store Id1 & Id2: Used for remote XML data systems  
Store Clock / Time  
Sync clocks at midnight: Set to 'yes' if master AK-SC255 is to send time to slave AK-SC255 units (on host network)  
Time Zone: Used to correctly time stamp e-mail alarms

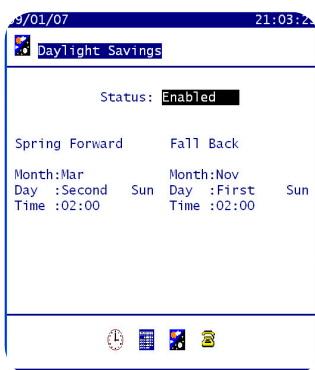
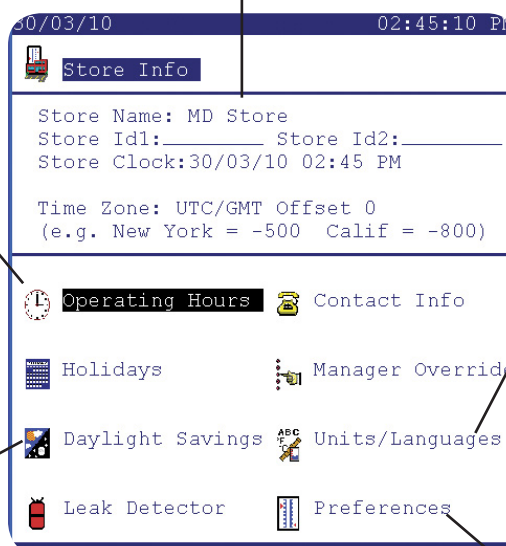

### Daylight Savings

Set as required

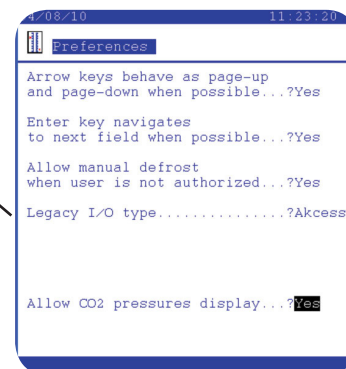

### Preferences

# File Management

**File Management** In order for correct support of Generic devices (EKC & AK2), the AK-SC255 needs to have a library of support files. If a remote connection via AKA 65 (Ethernet, modem or serial) to the AK-SC255 is required, then the same files that sit in the AK-SC255 need to also exist in the remote PC. This 'matched' state ensures that as a remote user you view exactly the same screen & controller details as is displayed locally on the AK-SC255. To assist the user in ensuring the files are the same versions and build dates, the File Management function allows closer inspection of the system files.

These files are known as EDF, Device list and UDF files. A description of these files follows;



### EDF (Extended Definition File)

This is a factory installed and managed file that resides in the AK-SC255. The EDF file describes the various controller parameters and allows various user functions & screens to occur. With a correct EDF file for a specific controller the user does not need to worry about which parameters to set for lighting, defrost and master control. In addition the EDF file allows the easy display of controller parameters and manual control features.



### Device List

This is factory installed and managed file that resides in the AK-SC255. The Device list file contains information about the Generic devices that the AK-SC255 can view. Effectively it acts like a 'table of contents' so the user and the system knows which devices can be supported.



### UDF (User Definition File)

This is a file that is designed and managed by the end user. The purpose of this file is to give the users of the system more freedom in filtering out screen content, history points and custom text. This file gets generated when the user takes an EDF file and creates a UDF in the 'UDF Software Tool'. The UDF file can be loaded into the AK-SC255 and 'applied' over the factory EDF, thus creating a more customer tailored system.

To gain access to the file management system log into the AK-SC255 at supervisor level, then navigate from the main menu to Configuration / File Management. Select 'File Management' and the file overview screen will be displayed. The file path displayed at the top of the screen is reference to the file location on the remote PC.

The visible list is a representation of the files the user has in the directory of the AKA65 installation. The upper part of the screen allows the user to select either the local directory (your PC) or the 255 directory. By toggling this menu a clear list of the files stored can be seen.

Main Menu / Configuration / File Management



File overview screen  
Option for local (your PC) or AK-SC255 view

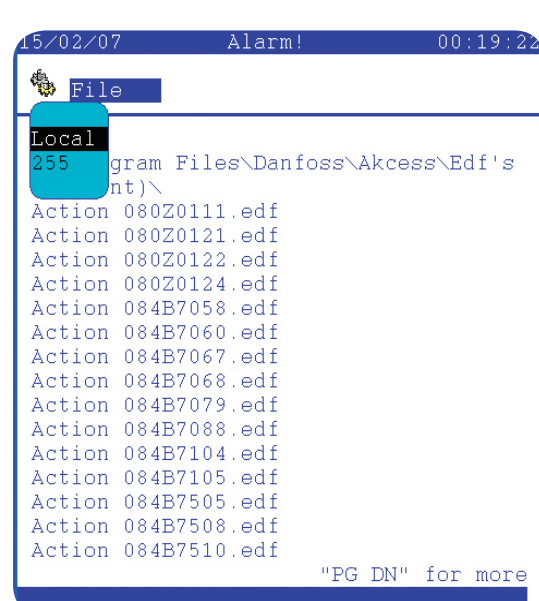

Once in the File Overview screen a drop down choice list is available to allow the user inspection of the file in question.

**Info** - allows further inspection of the file details

**Del** - allows the deletion of the file

**Write** - sends the target file on your PC to the AK-SC255

Once the Info button has been selected, the file name, version and time / date are displayed. For further information the view button can be selected and the file contents can be displayed.

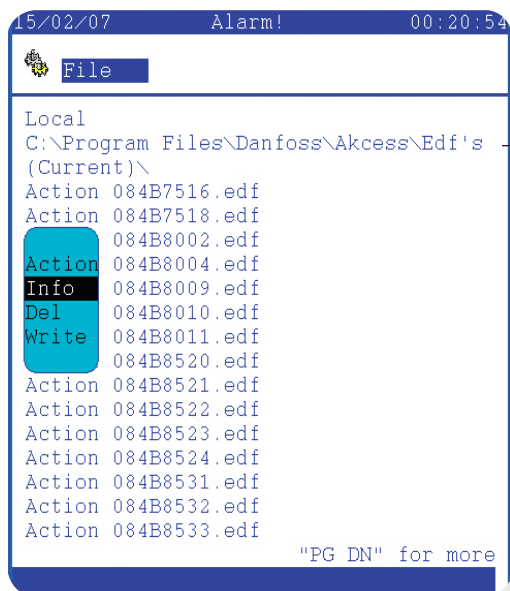

Local (your PC) directory

List of files shown, select **Info** to view file match information.

EDF files can get updated to match the very latest controller versions, in order to maintain an exact match when dialing in via AKA65 the files must match.

### File Mismatch check

When interfacing with Generic devices via the AKA65 software tool, both the AK-SC255 and your PC needs to have the same support files loaded (edf files). As generic devices get updated or new models introduced, new edf files are required to support these. Use the file management function to check that both PC and AK-SC255 files match, thus ensuring error free use.

### File Mismatch !

Same controller [type] EDF file but different version, this may lead to errors when commissioning / using controller

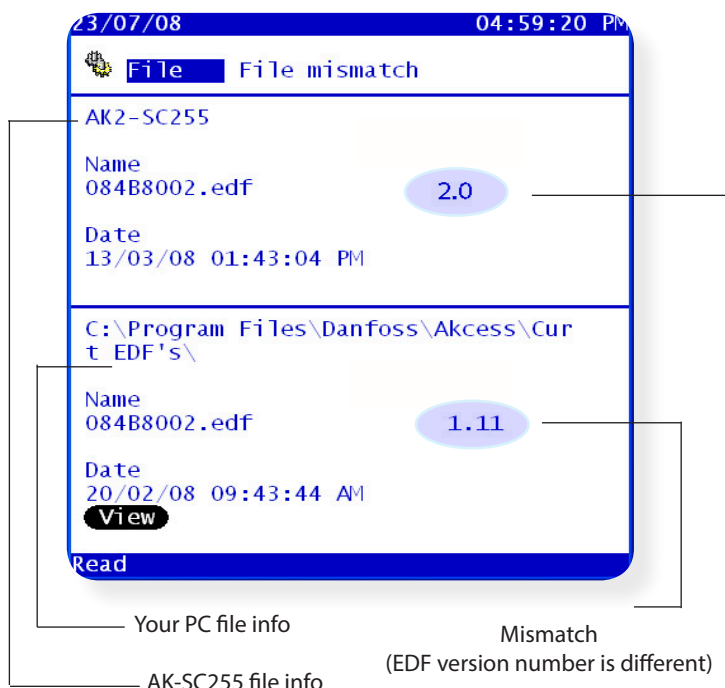

### Files OK !

Same EDF version number.

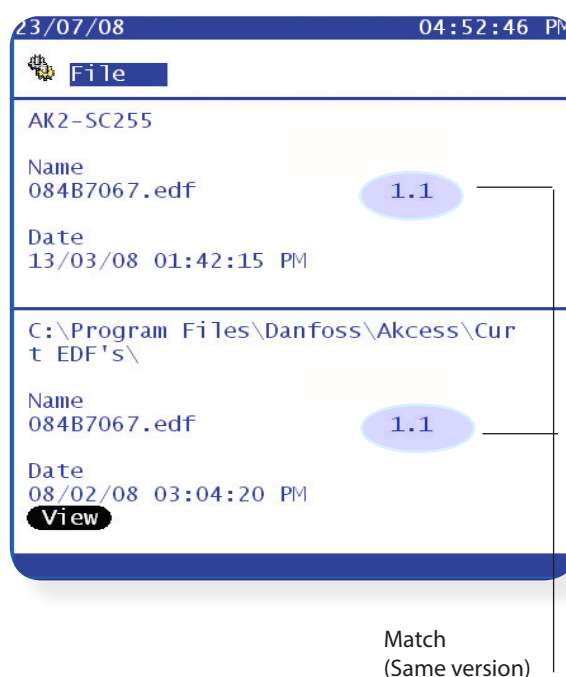

## Emergency file generation (emf)

Typically the AK-SC255 will come pre-programmed from the factory with a range of EDF (Extended Definition File) files that allow integration to the generic controller range. There are several benefits to having the EDF file system in the AK-SC255, for example:

### Allows full system commissioning offline

The EDF files (both within the AK-SC255 & AKA65 software tool) act as a controller template so no physical controller connection needs to be made in order to pre-program the AK-SC255 system, before even installed in the field.

### Manual Control

The EDF files automatically 'ties' into the relevant controller parameter(s) to allow easy 'Daily User' manual control, I.E. Manual defrost, Manual Case Lights, Manual Cleaning.

### User Friendly parameter descriptions

The EDF files also display to the user a more friendly text as opposed to 'raw' controller text. For example in a lot of instances the raw controller representation for defrost method would be 0,1 or 2. Here the EDF converts this and shows 'real world text' such as 'Hot Gas', 'Electric' and 'Off'.

### Pre-Programmed Auto History

Each EDF file has key controller parameter set to log, so all the user has to do to quickly start history collection is to press the 'Auto Configure History' button.

### Auto configured for Master control functions

The EDF files automatically have the relevant controller elements 'tagged' so that if the user wishes to enable master control functions (Defrost, Case lights, Night setback, etc) all that needs to be done is to assign a schedule to a controller. All the mapping of parameters is already done

The need for an 'emergency' file, (**known as a emf file**) comes from situations where there may not be any installed EDF files for the particular site installation. For example if a customer has some controller devices on the network that have no factory made EDF file support, the commissioning process can be limited by this as it may be difficult to communicate with the controller. In this instance, where there appears to be no standard EDF file the 'Emergency file generation' bridges' this gap. The resulting 'emf' file allows the user to communicate and operate the control device, with minimal loss of system functionality to that device.

The principle of operation is that upon scanning a network the AK-SC255 detects a controller or controllers that are not listed in the device.lst file contained in the AK-SC255. The AK-SC255 will then automatically 'extract' the raw controller 'description file' during the scan process. This extracted file (gdf description file) contains all the controller parameter lists and is then used by the AK-SC255 to create an emergency EDF, known as **emf**. Once the emergency file has been built the user can then commission the controller via the local AK-SC255. To remotely commission via the AKA65, the newly created emf file needs to be copied from the AK-SC255 to the local PC. See **File Management** section for details on how to perform this operation.

Most of the factory EDF functionality is included in the emergency EDF, see table below for precise scope:

Description of EDF functionality	Included in emergency EMF generation
Ability to select controller from drop down list in commission page	yes
Ability to copy / paste controller settings	yes
Ability to save controller setting to PC file	yes
Ability to display parameter reading in Evap & Pack overview	yes
Ability to commission (Read/Write) to all controller parameters	yes
Ability to assign (automatically Defrost schedule)	yes
Ability to assign (automatically Case lighting schedule)	yes
Ability to assign (automatically Po optimization)	no
View controller on Daily user web browser	no
Ability to use Auto Config History feature	no (define manually)
Ability to create EMF from AK2 based controllers	no



The following example screens demonstrate the emergency file generation system. After the AK-SC255 has been initiated for network scan the system will identify any controller devices that do not have corresponding edf support files. Automatically, the AK-SC255 will upload the controllers 'description file', this then forms the basis of the emergency file. During this process the screen will display a dialog box indicating the description upload.

After successful upload of the description file the AK-SC255 will allow the commissioning user to select the newly built emergency file, via the configuration drop down list. Note that the status bar at the bottom of the AK-SC255 screen will show the word 'emergency'. Commissioning of the device can now continue as usual. It is important to remember that if a remote AKA65 connection is being used, the created emf file will need to be copied to the PC AKA 65 directory.

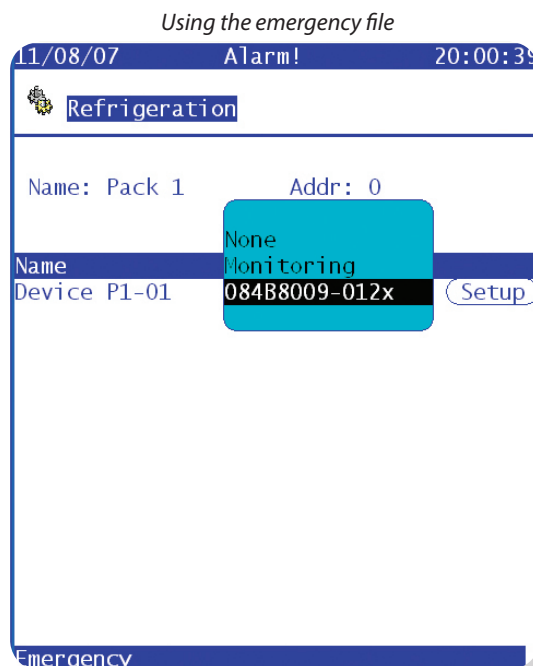
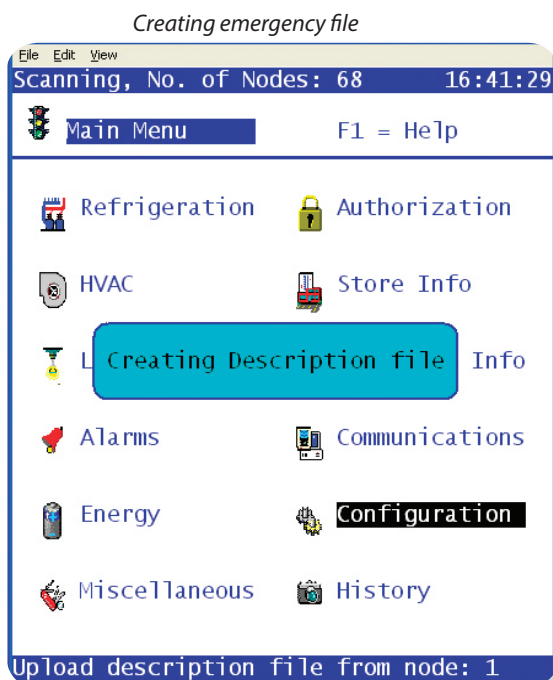

### Copying the emergency (emf) file to a PC

From the main menu, navigate to the configuration menu, then '**File Management**'. Select the first option (File Management), this will then display a list of the factory EDF & emergency files stored on the AK-SC255.

To change the directory view (either AK-SC255 or PC) use the option seen in the top left of the screen. For this example the emf emergency file (residing in the AK-SC255) will get copied to a connected AKA65 PC connection. Ensure 255 is shown at the top left of this screen - indicating the files on the 255 and navigate to the particular emf file down the list. On the left hand side against the emf file change the option from **Action** to **Read**. This operation will copy the emf file from the AK-SC255 to the PC - the destination on the PC is set by the AKA65 options (see below)

Change directory - select 255 or 'Local' (PC) directory

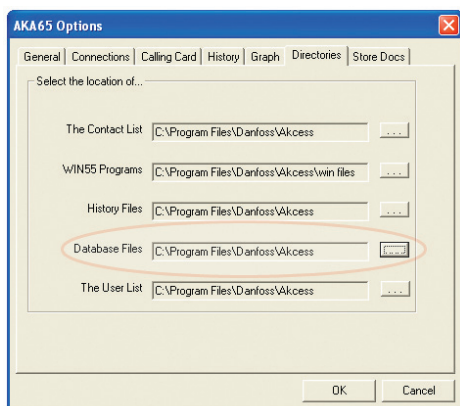
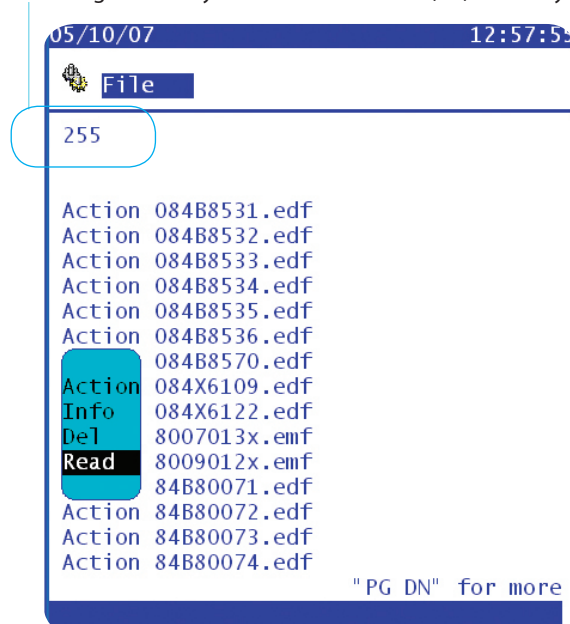

## Device Management

The other menu available under file management is '**Device Management**'. The purpose of this screen is to allow the user to select (individual, all or none) devices, thus forcing the system only to display the devices needed. As the support for a greater range of devices increases, this method will allow for better management of a large list of controller devices.

In the example below only three devices have been selected, the net result of this can be seen when the user configures refrigeration controllers. The drop down list now only populates the pre selected three control devices. This simplifies the choice available to the user as this list can represent many different devices. If required (and factory default) all the devices can be checked, thus making them available in the drop down list.

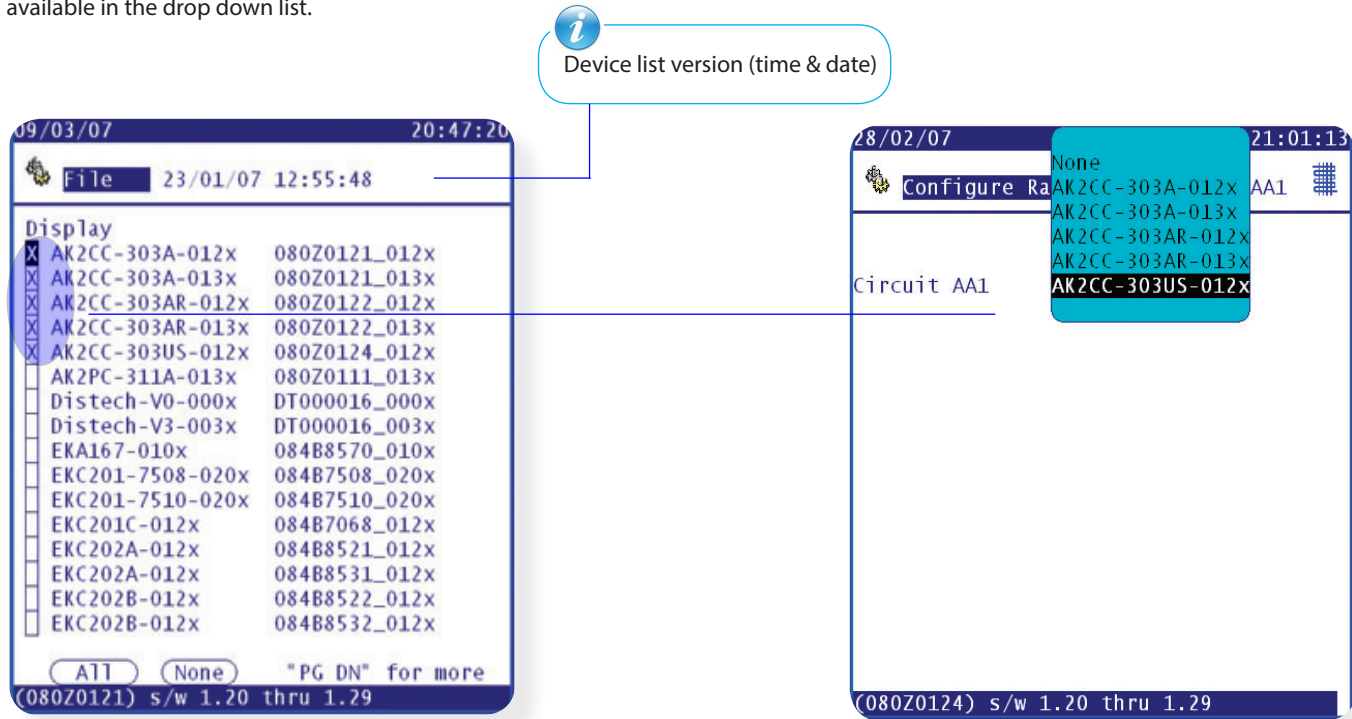

## Connecting AK-SC255 to an IP network (On-Line configuration)

This example describes how to connect the AK-SC255 onto an IP network that has an active DHCP server. Follow these steps if the AK-SC255 will reside on a valid IP network with DHCP services.

From the 'Main Menu' select the Communications option Communications

Next select and enter the 'Internet' page. Internet

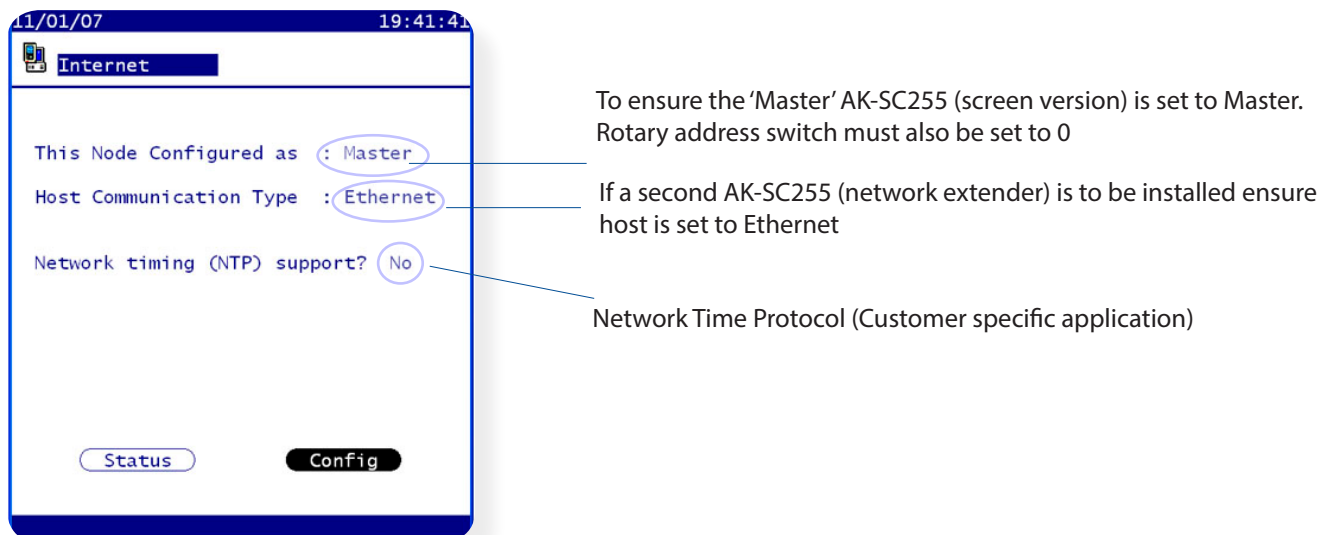

Select the 'Config' button to enter the area where the network settings are made. Upon the warning dialog box appearing select 'Continue'.

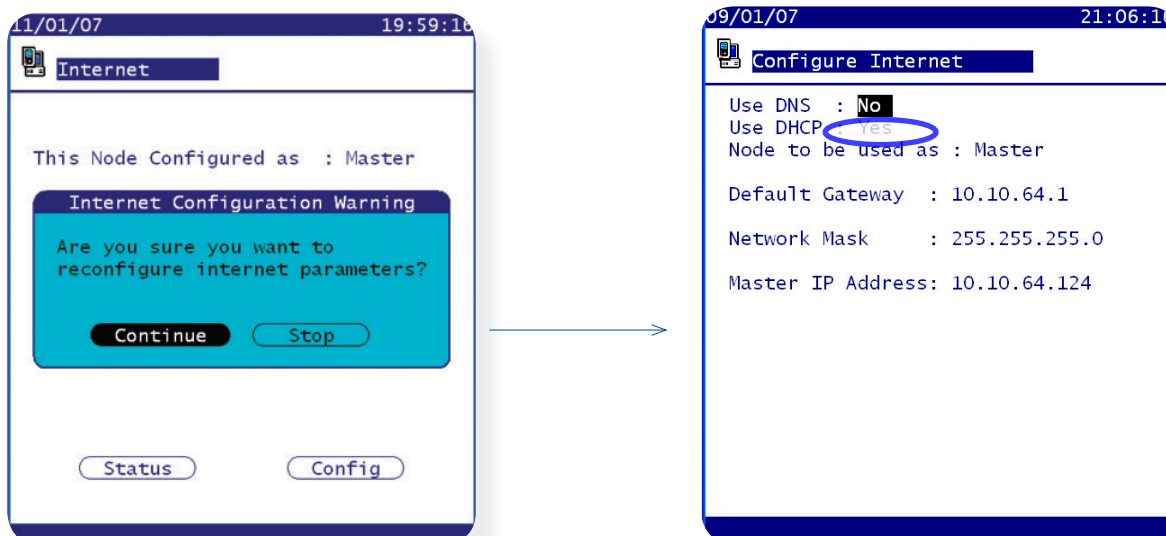

In the 'Configure Internet' page select the option **Use DHCP** to **YES**. At this point press the escape key to exit this page. Set **DNS** to yes if e-mail alarms are to be configured and the AK-SC255 has a DNS server available. A warning dialog box appears - select the '**Reset now**' option.

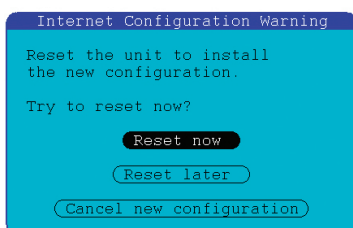

The AK-SC255 will now re-boot. During this re-boot sequence (if correct network is in place) the AK-SC255 will obtain an IP address from the DHCP server.

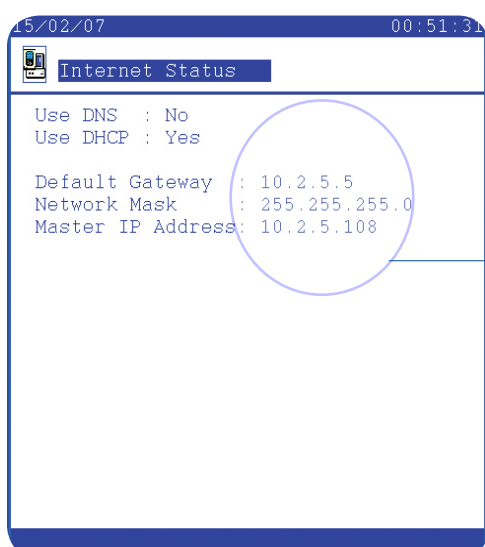

After a successful re-boot check to see that the DHCP server has issued a range of IP addresses. (Navigate from the main menu to Communications / Internet & check the 'Status' button. The **Default Gateway, Network Mask & Master IP address** fields should be populated.

Example Settings

If no DHCP address is given then the 'Use DHCP' line will read NO. If this occurs check that DHCP server is functioning correctly and all network connections are made.

## Connecting AK-SC255 to an IP (Ethernet) network (On-Line configuration)

Before reviewing this section consult with the Appendix section, where detailed information is provided on setting the AK-SC255 on Ethernet networks.

This example describes how to connect the AK-SC255 onto an IP network that has an active DHCP server. Follow these steps if the AK-SC255 will reside on a valid IP network with DHCP services.

From the 'Main Menu' select the Communications option Communications

Next select and enter the 'Internet' page.

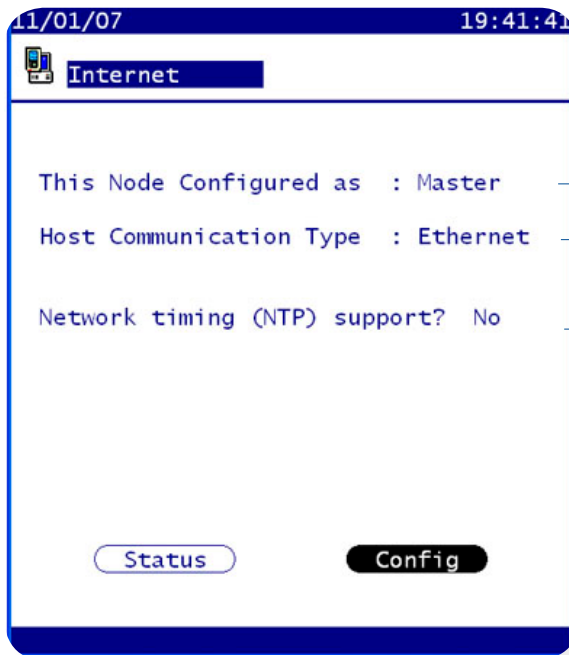

To ensure the 'Master' AK-SC255 is set to Master, the rotary address switch must be set to 0

If a second AK-SC255 (network extender/ slave) is to be installed ensure host is set to Ethernet (network address 1-9)

Network Time Protocol (Customer specific application)

Select the 'Config' button to enter the area where the network settings are made. Upon the warning dialog box appearing select 'Continue'. This will enter the area of the AK-SC255 where IP configuration settings are made.

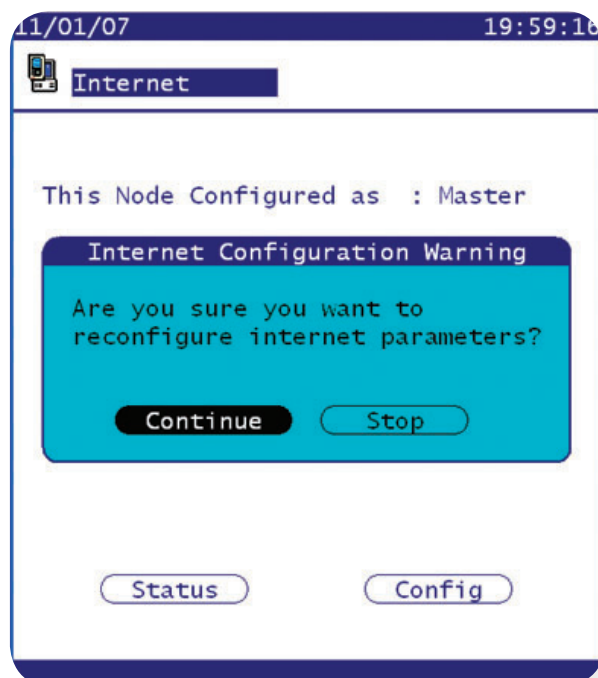

In the 'Configure Internet' page select the option **Use DHCP to YES**. If required, set **DNS** to yes if e-mail alarms are to be configured, and the AK-SC255 has a DNS server available. Continue to configure any remaining parameters required and then escape from this screen. Escaping from this screen will bring up a dialog box asking to reset - ensure to Reset now. The AK-SC255 will now re-boot, during this re-boot sequence (if correct network is in place) the AK-SC255 will obtain an IP address from the DHCP server.

**DNS?** (Domain Name Server)

Select YES if DNS services are going to be used.

If DNS = YES the option to add a preferred hostname will become available

**DHCP?** (Dynamic Host Configuration Protocol)  
Select YES if an IP address is to be issued from a DHCP server. The issued IP address(s) will form the address range for the AK-SC255

**Use External Internet (Yes / No)**

Set to yes if the AK-SC255 is be accessed via a WAN connection (i.e. Public Internet)

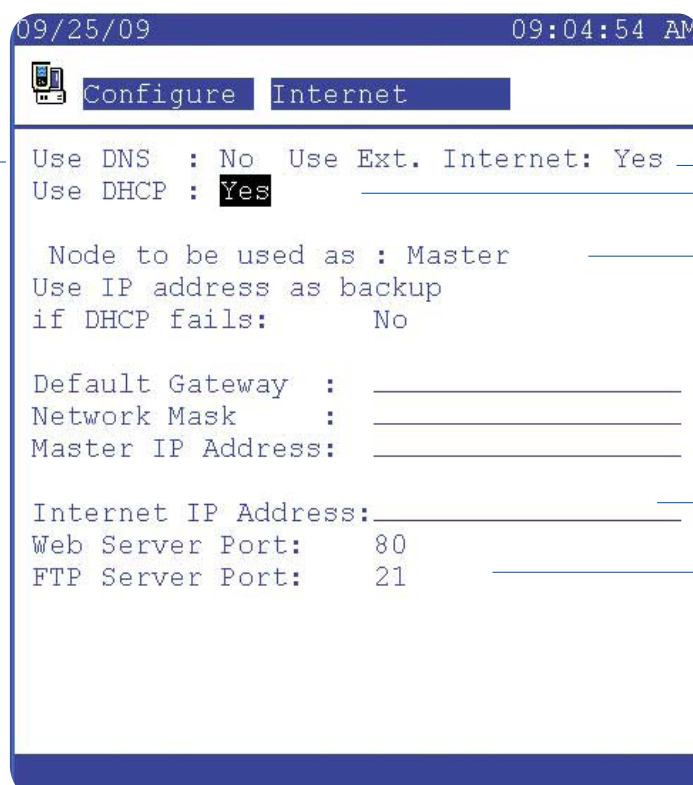

It is possible to contact the Master or slave units by using a DNS name.

External IP address for use on WAN

User defined Web & FTP ports

**Use IP address as backup?**

Select YES if you wish the AK-SC255 to run off the backup IP address after any DHCP server failure. Enter the IP address(s) here or automatically have the AK-SC255 place it's current address from the 'Internet Status Screen'.

**Reset**

Once all the necessary configurations have been completed ensure that the AK-SC255 is Reset

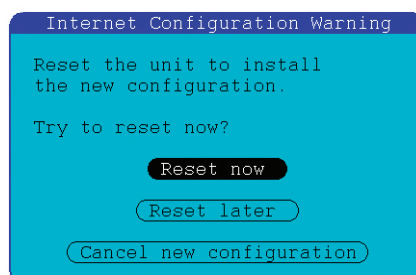

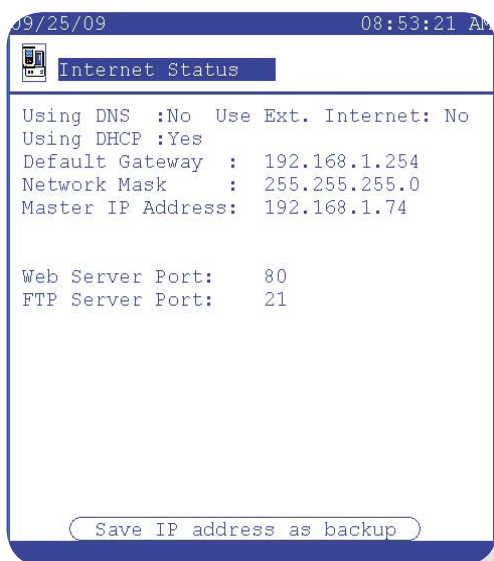

### Internet Status page

Seen here with DHCP enabled. After the AK-SC255 resets the DHCP server has issued valid IP addresses.

If required, the 'Save IP address as backup' button can be used to apply the IP address seen on this page.

## Network I/O Scan

### (Identifying controllers & AK2 I/O on the network ready for further commissioning tasks)

After the initial settings have been configured, the AK-SC255 can now be prepared for Network scan(s). A network scan function is used on the AK-SC255 to establish controller devices or nodes on the connected network ports.

From the Main Menu select **Communications** -> **I/O Network** then select the **Rescan Network** button



Ensure a valid EKC 'o03' or rotary assigned AK2 address in each of the devices. Ensure that device addresses do not exceed an address limit of 162 (AK-SC255 limit).

### Performing a network Scan (Rescan channel selection page)

Prior to a network scan ensure all devices have correct power, network cable, communication cards and unique net address. Once in the rescan channel selection page a user selection of network protocols is available.

Network channel selections

Network channel selection	Details
<input checked="" type="checkbox"/> Lonworks® TP78	select this channel to scan for I/O modules, or case controllers connected on the TP78 network
<input checked="" type="checkbox"/> SNMP	select this channel to scan for SNMP Ethernet controllers
<input checked="" type="checkbox"/> Modbus RS485	select this channel to scan for approved Modbus devices (EKC case controllers, SLV and WattNode power meter) Note: if modbus is used for controller bus then it [modbus network] will not be available for host network communications - use Ethernet as an alternative for host network
PI 100-200	select this channel if a Danfoss PI-100 or 200 is being used to interface to legacy devices
Lock/Unlock EKA displays	use this function if using the EKA 167 digital display
Lock/Unlock EKA display	

**Note:** When selecting Modbus a warning notice pops up to advise the use of only compatible devices on the Modbus network. Only use the following devices;

- Danfoss EKC Modbus enabled circuit controllers
- Danfoss SLV variable speed display case/circuit
- Wattnode plus modbus power meter
- Siemens lighting panel
- Carrier UPC

**WARNING:**  
 Only use COMPATIBLE Modbus devices on the AK-SC255 modbus network.  
 Press key 1 to CONFIRM  
 Press key 2 to CANCEL

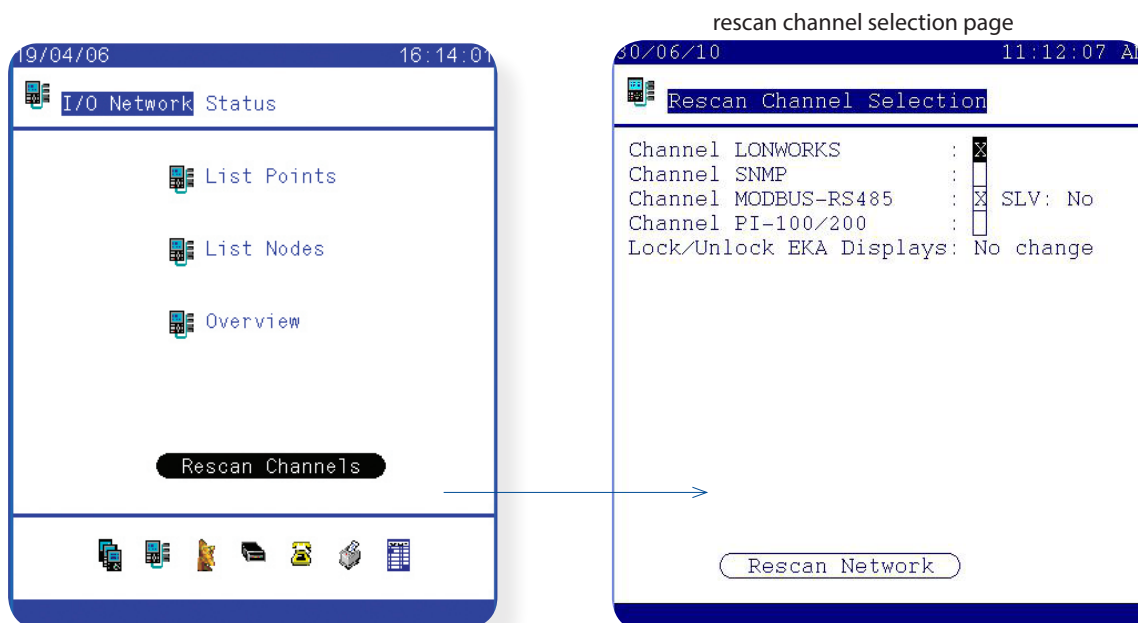

Once set, see the scan progress at the top of the screen.

First time scans occur automatically, however utilise the 'Rescan Network' button to force a new network scan at any time.

Note that if using EKA 167 Modbus display the local button functionality can be locked as to avoid any unauthorized changes.

Using the 'Rescan Network' button will also generate a scan report indicating the quantity of nodes detected.

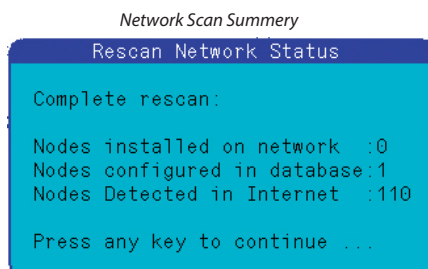

## Review Scanned devices

After a network scan the detected devices populate an overview list found in the **I/O Network** page. Before commissioning the AK-SC255 check this list and ensure all required devices are present.

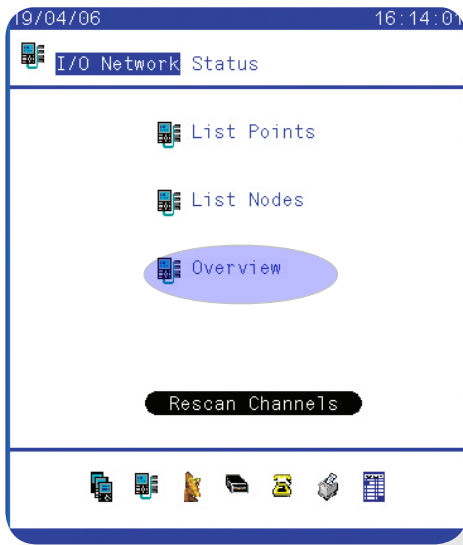

From the 'Main Menu' go to the 'Communications Menu'. From the Communications Menu go to the 'I/O Network' menu. Select 'Overview' and then 'Generic' to view this list.

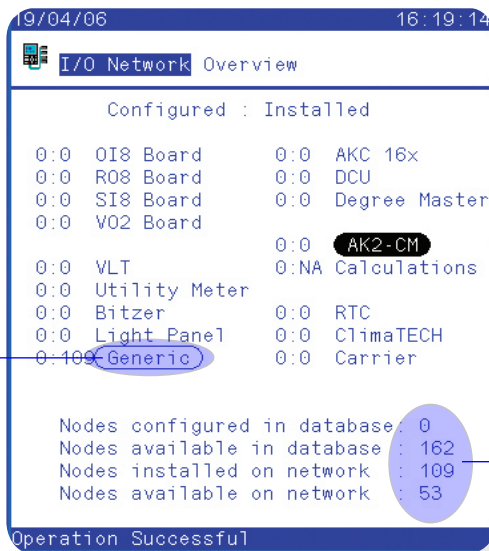
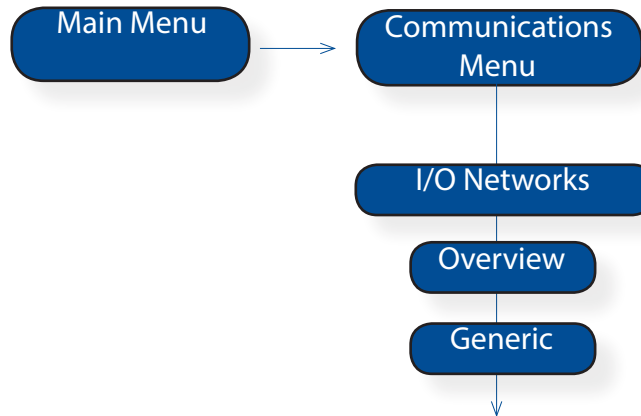

### I/O Overview Page

Various configuration details can be seen from this page.

Select **Generic** to view EKC / AK2 'Generic' devices.

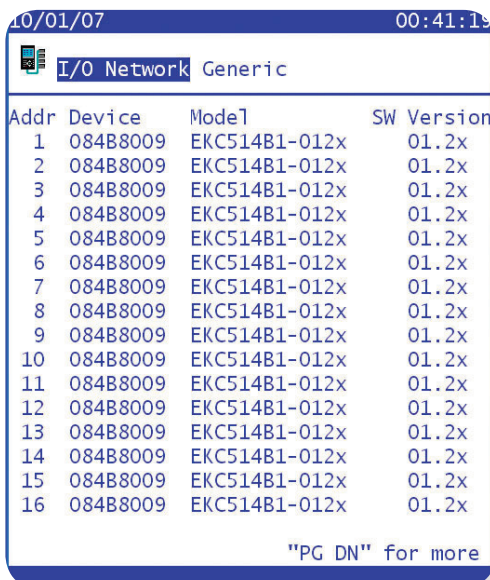

#### Nodes Configured in database

After a new network scan this will show 0 and indicates that as yet no controllers have been setup in the AK-SC255 database yet. (The commissioning phase will populate the database and therefore this value will reflect how many controllers are in the database).

#### Nodes available in database

Indicates how many controller (addresses) are available

#### Nodes Installed on network

Indicates how many nodes have been recognized as a result of the scan

#### Nodes available on network

Indicate how many nodes (controller addresses are still available)

*AK-SC255 Controller capacity is shown in the 'AK-SC255 Fact sheet DKRCE.ED.R1.A1.22 / 520H1486)*



## Generic Case Controller Configuration (AK2, EKA and EKC Case Control)

Assuming that no previous case control devices have been configured in the system, new controls can now be added. The commissioning of controls can be established by selecting the 'Configuration' menu - via the Main Menu and then Refrigeration.

From the Configuration menu select Refrigeration.

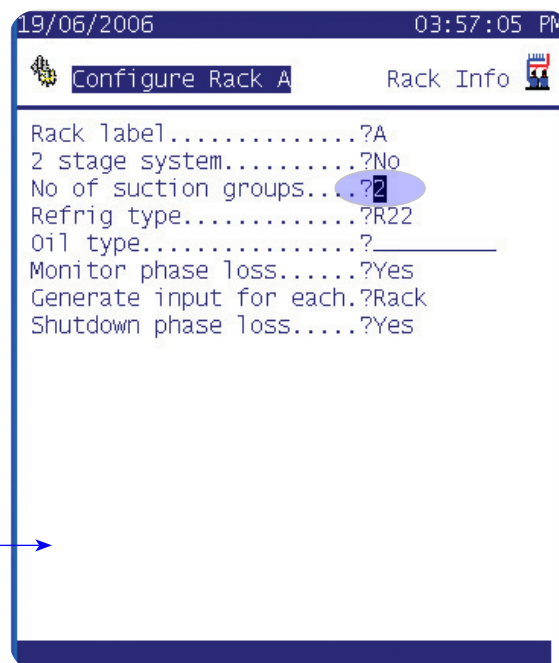
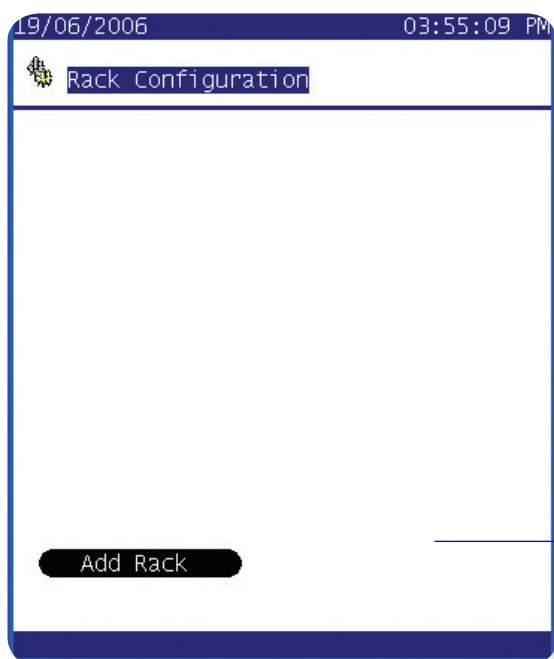

Select the 'Add Rack' option

The Rack configuration page will be displayed, define the number of suction groups, this enables further Rack configuration. Jump back one screen and the configure screen will now display multiple icons. Select 'Evaporators'.

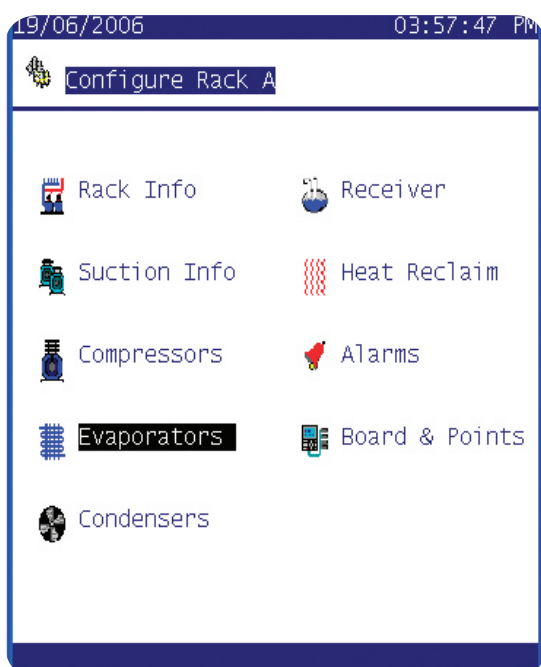

**Evaporators**

To configure a generic case controller device (EKC & AK2) select 'Evaporators' from the Rack configuration screen.

Select the appropriate suction group, and fill in how many circuits are required.

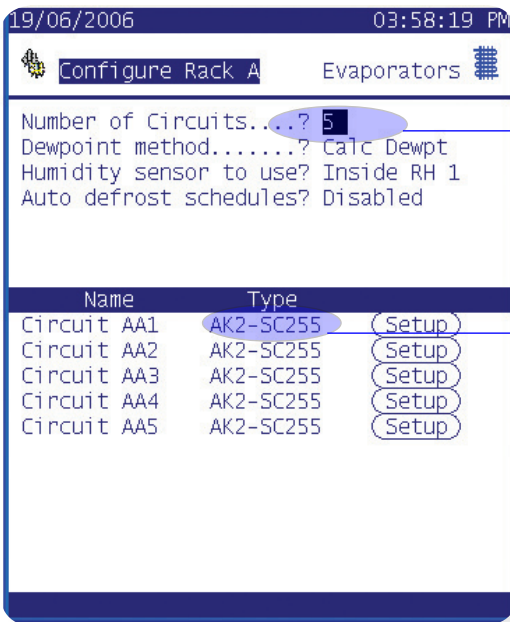

Fill the number of circuits required.

Next, select the 'Type' via a drop down list to choose method of circuit control.

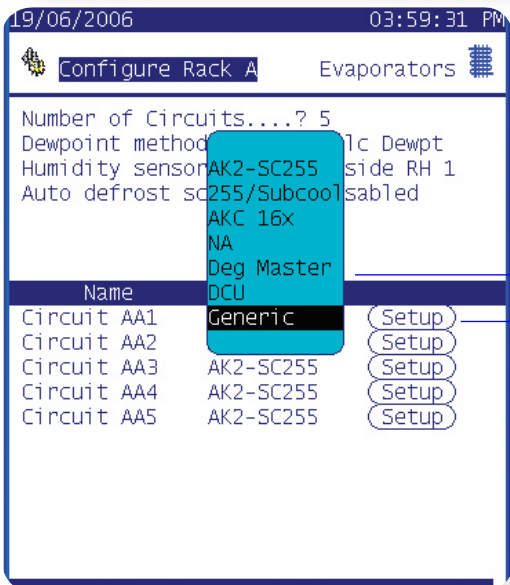

To utilize the EKC and AK2 case control devices select 'Generic' from the drop down list.

Then having selected 'generic' press the Setup button to configure the device.

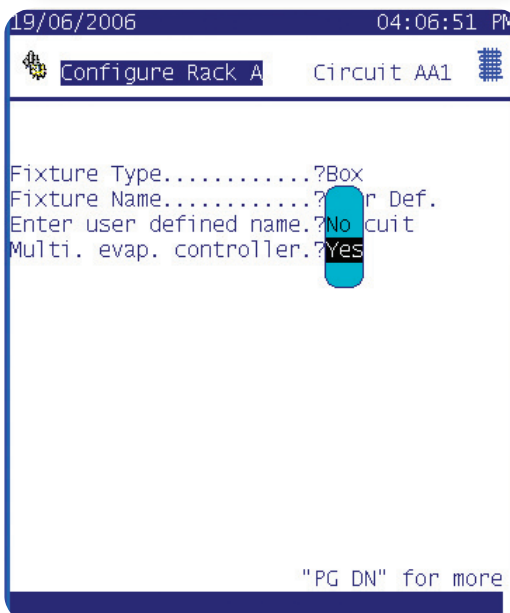

The AK2 case controller has the ability to control up to four case section evaporators, if using an AK2 controller select 'Yes' to the question..Multi evap controller..?'



If 'NO' is selected for Multi evap controller then the following config Rack page will contain a drop down list of EKC (non multi evap) controllers. See next page for example

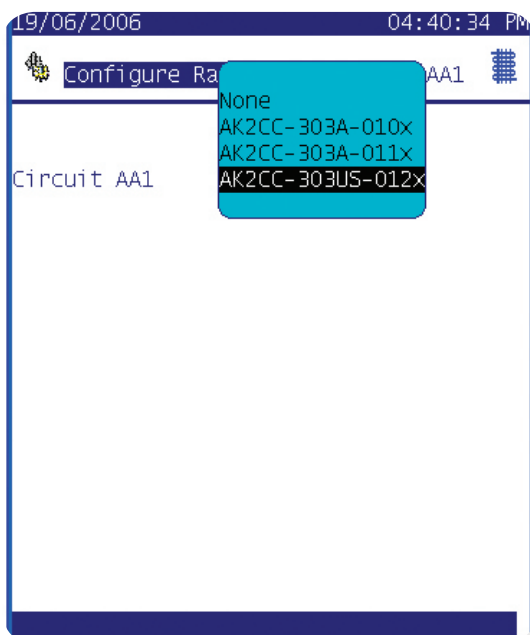

From the drop down list select the appropriate generic device that matches the controller to be configured.

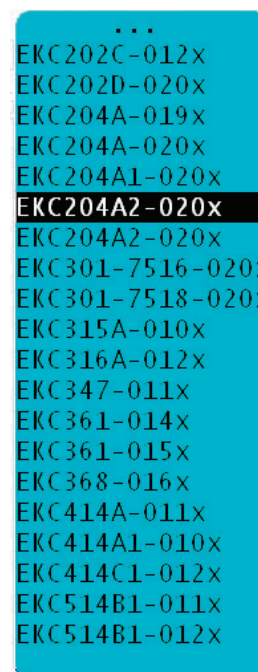

If 'NO' was set to the question, "multi evap control", then a list containing EKC (non multi evap) case controllers will be presented.

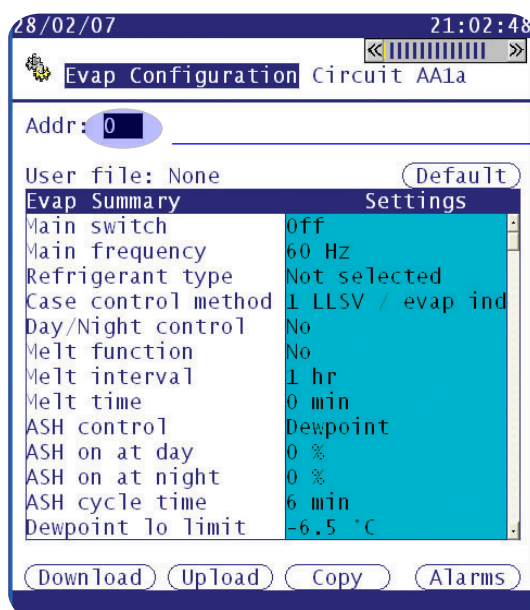

Fill in the address corresponding to the physical controller address on the network. AK2 controller utilize a rotary dial address switch, EKC use o03 Address parameter.

Next, go through each function group and configure controller parameters as per requirements. If commissioning on-line, any parameter that gets changed in these screens will get written down to the controller. Once you have configured the controller the option to use the copy / paste function is available. This will save time if another controller (same type) has to be set up.

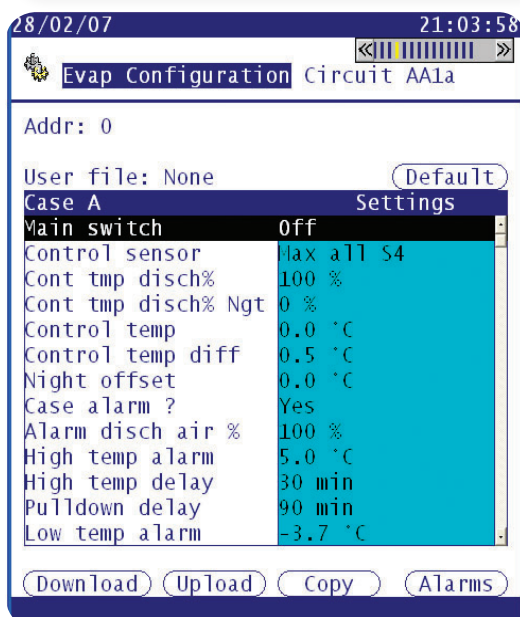

Use the 'page tab' control to navigate through the various controller function menus. If navigating via the local AK-SC255 keypad, then use the shift key to apply 'focus' to the page tab control. Then press (release) the shift button + left or Right key, this will page through the controller function pages.

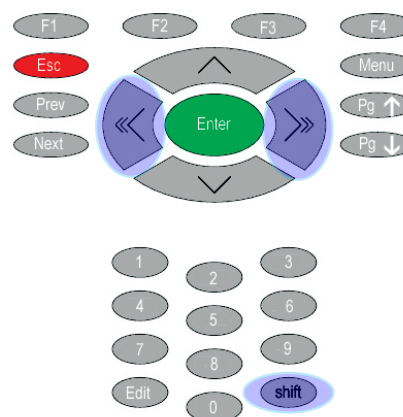

### AK-SC255 / AK2 controller Alarm setup

The Alarms button on the bottom of the evaporator 'Generic' configuration page will open up the alarm configuration page. Here the AK-SC255 can be configured to act on any of the controller alarm parameters. In the instance of AK2 controllers where over 150 alarm types are available a selection option is available. The current AK-SC255 alarm limit capacity per AK2 controller is 150, use the select / de-select box(s) to populate the required alarm points from the controller.

Consult the **Alarm Action** section in this manual for details on setting up the central alarm configuration

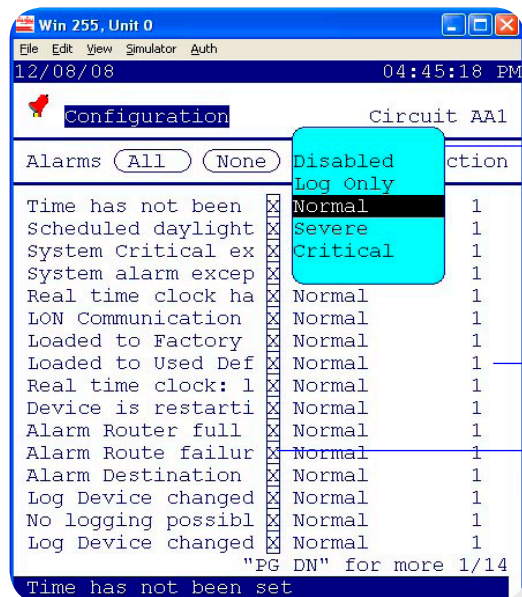

**Disabled** - No alarm will be sent

**Log Only** - AK-SC255 will log alarm only - no alarm output

**Normal** - Alarm sent ONCE

**Severe** - Alarm sent & re-sent (re-trigger time set in alarm action configuration)

**Critical** - Same as Severe but with separate & independent re-trigger time

Select appropriate alarm action number (see central alarm configuration for further details)

Select / De-select required alarm points in the AK2 controller. If more than 150 points are attempted a warning dialog box will appear.

The maximum amount of alarms for this device has been reached.

### User file

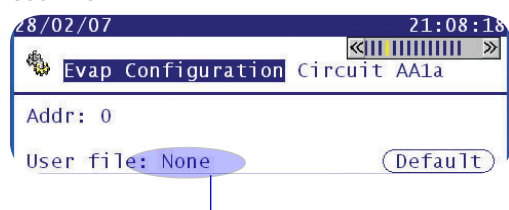

Located in the evaporator 'Generic' configuration page is the User File option.

User file: User Defined File (UDF) changes the factory controller default text, language, and history points as seen on the AK-SC255. Used for customer tailored requirements. Contact your Danfoss representative for details and assistance on UDF file management.

#### Default button

Used to apply the factory defaults (controller text, settings, history) to the device in question. Use the 'download' button to download these default values to the device. If a UDF file is being used then the default function will apply these values.

### Download, Upload and Copy functions



#### Download

The download button is used to download or initialize settings **FROM** the AK-SC255 database **TO** the control device(s). This function is typically used when an off-line database has been created and these settings need to be pushed down to the controller.

Use the Download button with care as this will cause any settings in the controller to be overwritten by AK-SC255. Off-line programming is described later in the manual.

#### Upload function

The upload function can be used to 'pull back' controller settings. For example, if there is a requirement to upload and then copy / download the values to other (same type) devices this function can be used. Use the upload function at any time to retrieve controller settings.

### Copy Function

If there are multiple controllers of the same type (controller type and software version) the 'Copy' function can be used.

For example if the associated controllers with *Circuit AA1* are of all the same type you need not replicate the controller parameter settings. The copy function allows the controller 'settings' and 'alarm configuration' to be copied into the system database. To 'paste' these settings down to the controller use the 'Init' (initialize) button (controller address must be in place at device and AK-SC255 for the Init function to work)

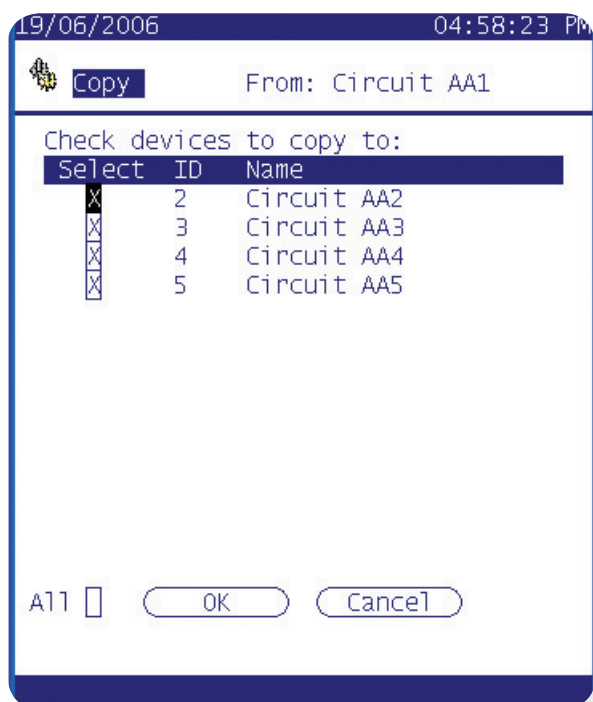

## Energy Meter Options and configuration

The AK-SC255 has the ability to connect to power meters and thus record electrical usage and load. Two main methods of data collection are possible, via a meter pulse output or data communications. For power meters that have a pulse output the AK-XM107A I/O module should be used. This module allows the collection of pulse signals and thus the display of KWh. In addition to pulse collection the AK-SC255 also supports (amongst others) the WattNode Plus modbus meter (Model WNC-3Y-208-MB). The following section provides details on the setup of both meter types.

### Pulse Meter configuration

Assuming the power meter is in place and the pulse output from the meter is connected to the AK I/O module (type XM107A) and all units are online with the AK-SC255, follow the steps to register KWh values.

- From the Main menu navigate to Configuration and then Energy. From the Energy menu, select the Utility Meter Menu and finally the configure icon.
- Against the question 'No. of KWh Utility meters?' enter the quantity of meters required (max 80).
- Provide a suitable name (*overwrite the factory text of meter*) and define the type - in this case select 'Pulse' from the drop down menu (seen as second meter in screen shot below).
- Via the Setup button, access the configure screen for the WN Plus meter. Enter the board & point address that the pulse input has been wired via the **Board & points** icon.
- Enter the **meter setup** icon to define the window size, Watt-hours per pulse and if collection of history if required (The window size can be set to 15, 20 or 30 mins. The window 'slides' forward so that it always contains the most recent period of time. Every minute the accumulated KW during that minute is recorded).

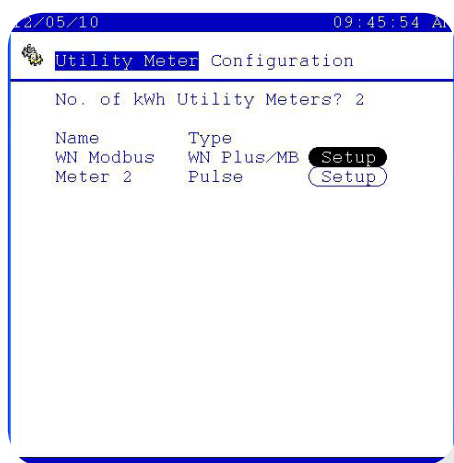

- Enter the required amount of meters (max 80)
- Select 'WN Plus/MB' to support the WattNode Plus Modbus power meter
- Select 'Pulse' when using the XM107A module

### WattNode Plus Modbus power meter configuration

For more detailed information on power consumption & electrical performance the use of a data enabled power meter should be considered. The WattNode Plus modbus power meter is supported in the AK-SC255 and utilizes the built in Modbus field bus. The following section describes the required steps to connect & configure the WattNode Plus meter over a modbus network connection.

Before any configuration can take place, ensure the meter is securely wired, powered up and has a valid Modbus network connection back to the AK-SC255. The Modbus device address, baud rate and parity **MUST** be set first before attempting connection to the AK-SC255. AK-SC255 supports the following setup:

- Address range is from 1 to 120 for R version (or 160 for E version).
- Baud rates are 9600, 19200 and 38400.
- Parity can be none parity or even parity.

The factory configured (default) options for the WattNode Modbus meters used with AK-SC255 are even parity and 38400 baudrate (Opt EP, 38k). The desired address can be set by switching DIP switch positions 1-7, each of which add a different value to the address. The data format is 1 start bit, 8 data bit and 1 stop bit. The factory defaults can be restored by switching all the DIP switches to the OFF position and leaving them there for 10 seconds, then setting them back to the desired address.

The example below shows how to wire the communications to the WattNode Plus meter from the modbus RS485 port on the AK-SC255.

### Modbus RS485 Considerations

- (1). To avoid errors due to the signal reflections or line coupling, it is necessary to terminate the bus at the beginning and at the end (inserting a 120 ohm 1/2W 5% resistor between line B and A in the last instrument and in the Host interface).
- (2). The network termination is necessary even in case of point-to-point connection and/or of short distances.
- (3). For bus connection it is suggested to use an AWG24 balanced pair cable and to add a third wire for GND connection. Connect GND to the shield if a shielded cable is used.
- (4). The GND is to be connected to ground only at the host side.

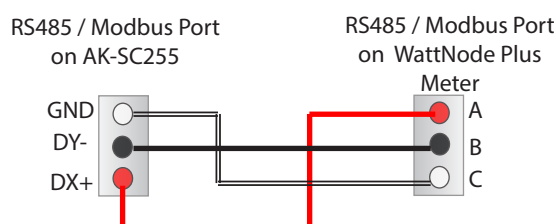

### Configuration of the WattNode Modbus Energy Meter

An AKSC-255 system can monitor Danfoss-approved energy meters such as WattNode Modbus meter which have a Modbus RS485 interface. After installing the energy meter according to OEM instructions, the meter should be connected to the I/O network and becomes a node on the (Modbus) network (only one meter connected can be used for demand limiting). Follow the instructions below to configure the WattNode Plus meter on Modbus.

From the main menu select Configuration, then 'Energy'. Select Utility Meter then 'Configure'.

Enter the number of kWh meters to be configured, a drop down selection list will then appear.

Enter a suitable name for the meter (11 characters).

Against the WN Plus/MB type select the **setup** button, this will present the WN Modbus configure screen

Select WattNode MB (Modbus) from the drop down selection

Provide an address in the upper right hand of the screen (enter the address that matches the one already set in the WattNode meter (via the DIP switches))

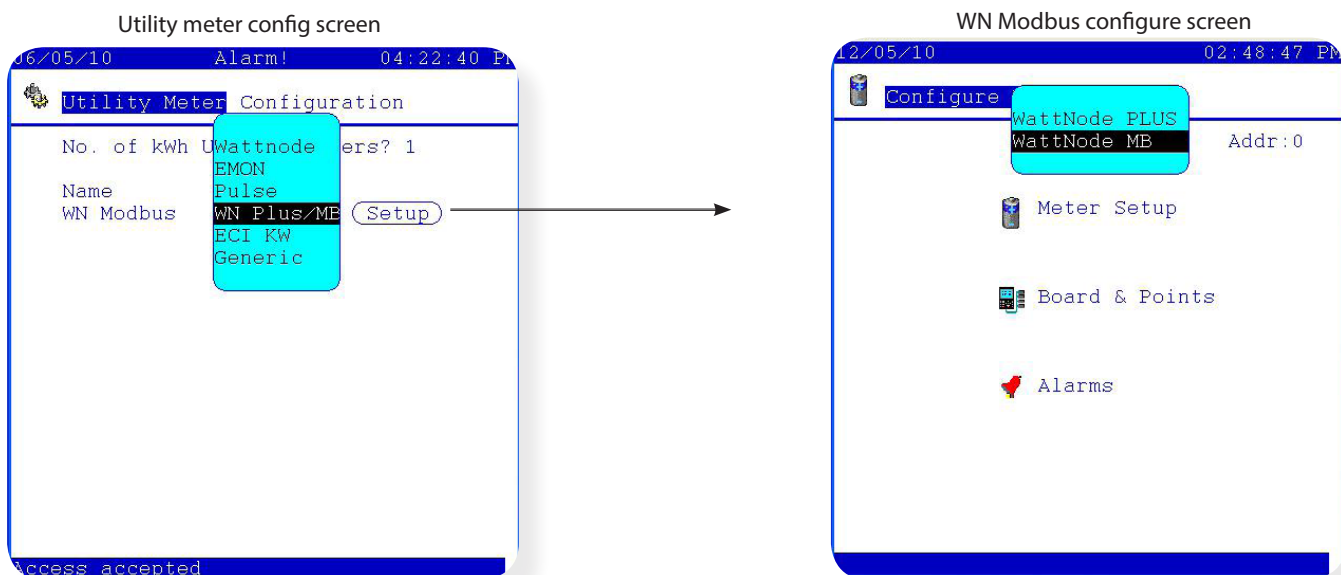

Enter the 'Meter Setup' screen, and the following areas are available for configuration;

- Amperage: It is used to set the rated current of an attached current transformer.
- Collect History: Whether or not history is to be collected from this meter.
- Use unit for demand limit: Whether or not this meter is to be used for demand limiting. Page down then shows the demand period (5-720, default 15) and the interval over which demand is calculated. Demand is defined as average power over a specified time interval. Demand subintervals (1-8, default 1):  
The number of divisions of the demand period used when calculating a "rolling demand" using a "sliding window."

First time meter configuration or subsequent changes require the meter is initialized. From the configure meter screen select the Board & Points icon. Select the Init button and then press ENTER to begin the initialization process.

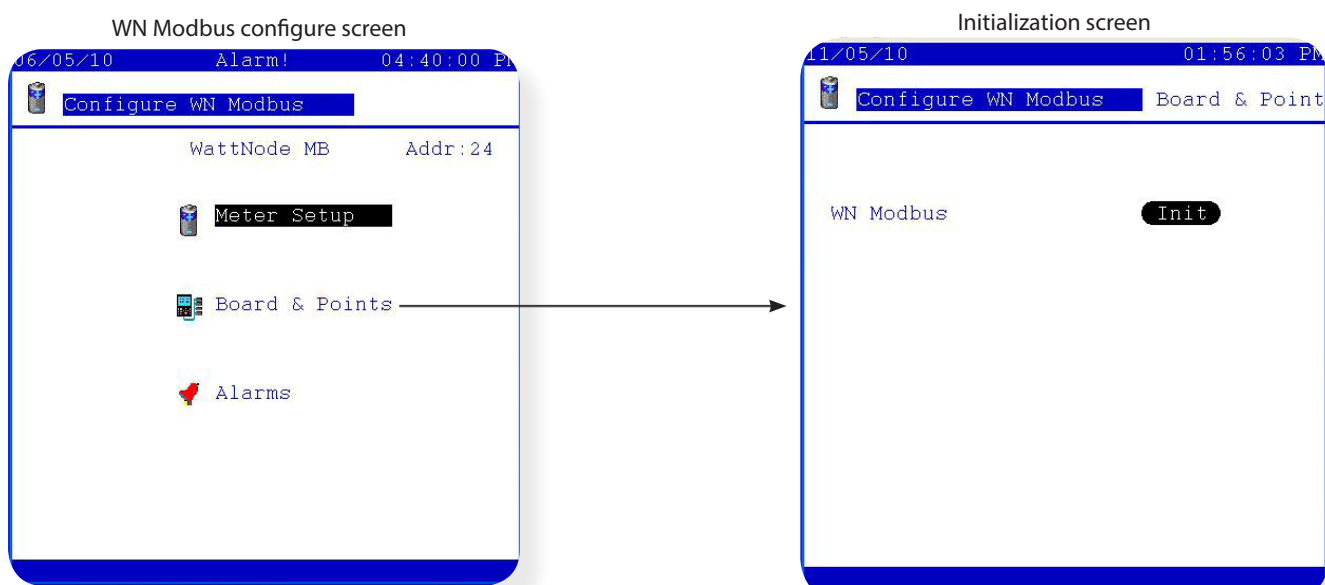

If alarming is required, navigate to the configure meter alarms screen. All available parameters from the meter will be displayed and can have appropriate alarm actions assigned.

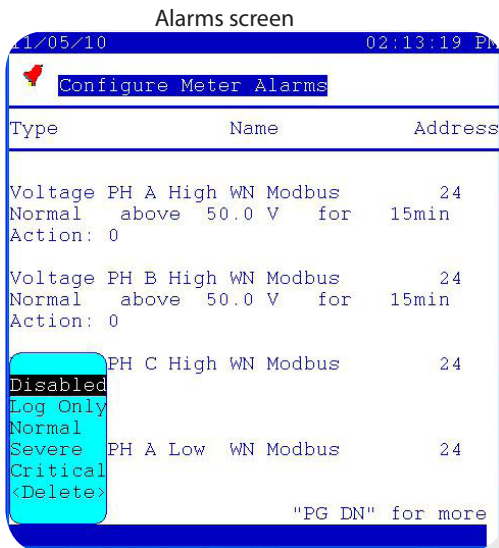

After the meter has been configured via the steps previously described, a (modbus) network scan is required. Navigate to the rescan channels page to perform a modbus scan (ensure modbus is selected in the channel selection table)

### Meter Status and Service Screens

To view current status of meter values navigate to the Utility meter screen (Main menu->Utility meter) and select the required meter. The current kWh reading will be shown, by selecting this value and pressing enter more detail is shown (see below).

- kWh Consumption: Total consumed energy (KWH).
- Current KW Load: Total demand power (KW). Demand is the average power over a specified time interval (Demand period).
- Peak KW: Peak demand power (KW).
- Total Power: Total instantaneous power (KW).
- Total Reaction Power: Total instantaneous reactive power (KVAR).

For meter service, press the service icon at the bottom of the page. the following Reset Commands are available:

- KWH Counter Reset: Reset all resettable energy registers and counters.
- Peak KW Value Reset: Reset peak demanded power.

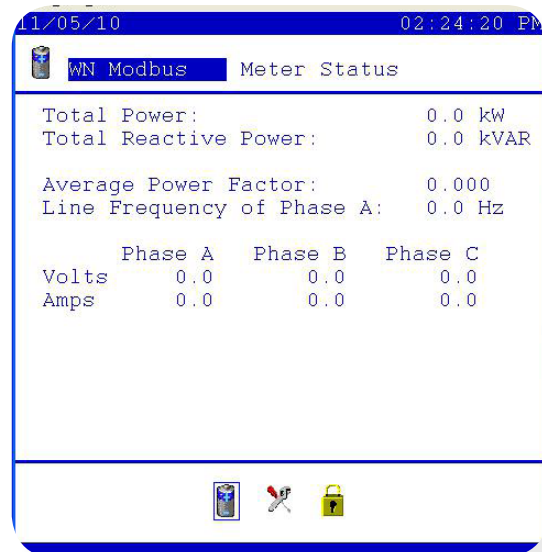
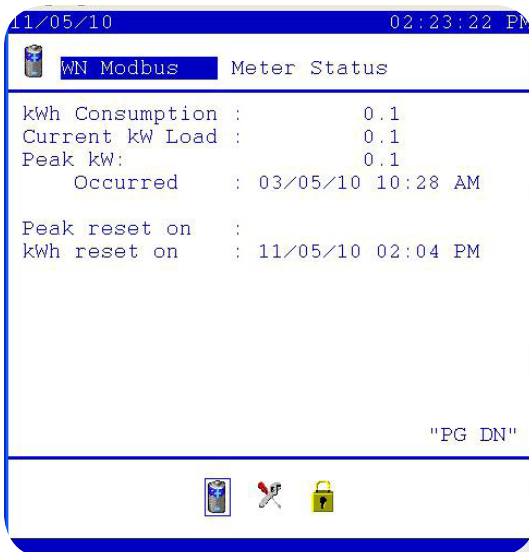



## Master Control / Energy Optimization configuration

One of the major benefits of installing the AK-SC255 and Danfoss controls is that intelligent functions known as Master Control can be configured. The proven concept of master control function is to provide system wide schedules, and targeted energy optimization control. The following section details the simple processes involved in creating, modifying and implementing these master control features.



### Schedules

Schedule configuration and management can be accessed via the Configuration / Schedules page. Once in the Schedule Management screen the system asks for the number of schedules required. A maximum of 100 schedule types can be set and configured in the AK-SC255 system. The available schedule types range from:

- Misc - Not currently used
- Case Lighting - Used to control the case lighting
- Night Setback - Used to control the automatic raising of controller set point at desired time (in association with Danfoss controllers)
- Shutdown - Used to automatically shut down a controller via the 'Main Switch' command
- Defrost - Used to control the complete refrigeration systems defrost schedule
- Coord Defrost - Used in conjunction with coordinated defrost feature in Danfoss controls

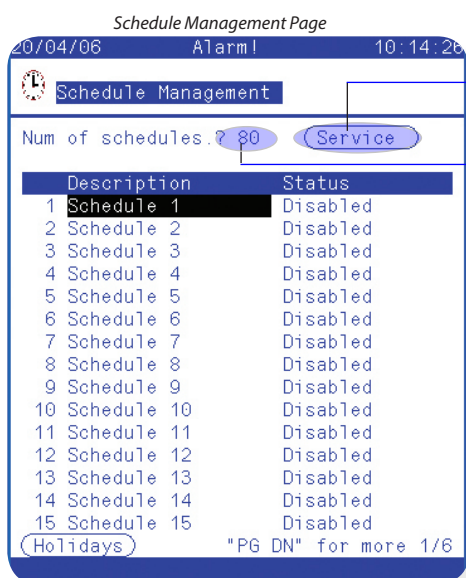

Use the Service function to globally Enable or Disable ALL schedules function

Enter number of schedules required

Using the dropdown list, select the required schedule type

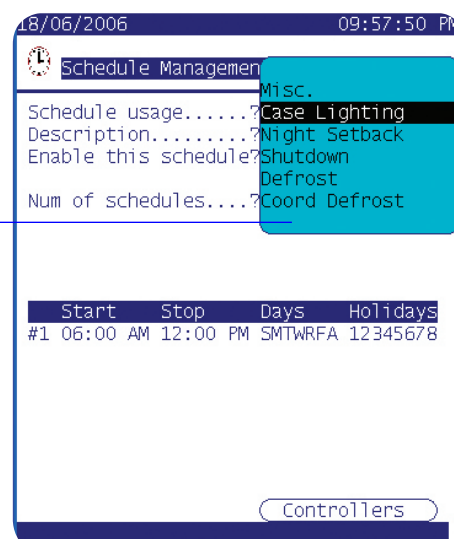

### Case Lighting setup

Case lighting times vary from application to application but the following example highlights the process needed to configure and implement a typical store case lighting schedule. In this example Store A has case lights on for 24hrs from Monday through to Saturday night, with Sunday having specific on times. Select Case Lighting from the drop down list and continue to configure the schedule.

#### Example - Store A

	ON		OFF
Mon	08:00		-
Tue		24hrs	
Wed		24hrs	
Thur		24hrs	
Fri		24hrs	
Sat	-		22:00
Sun	10:00		16:00

The resulting configuration in the AK-SC255.

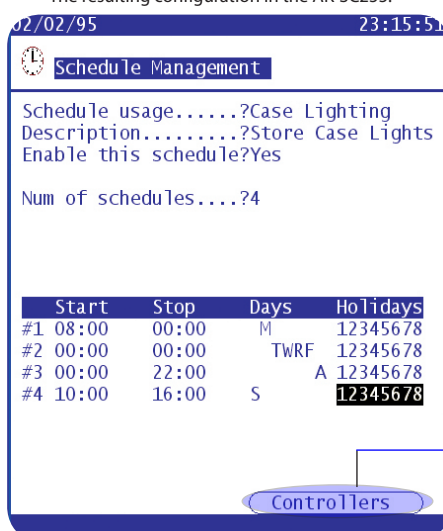

Ensure controllers are 'linked' to schedule

To complete the setup, select the controllers required for the schedule

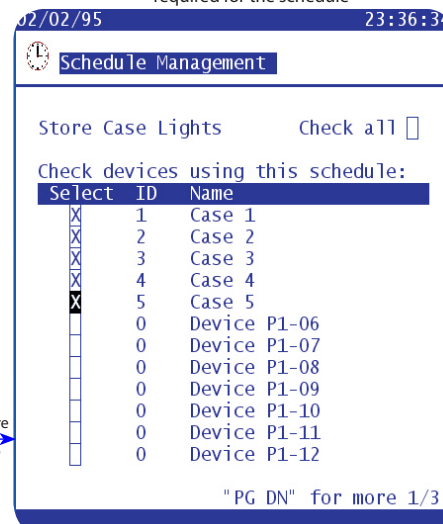

### Case Defrost setup

The AK-SC255 has the facility to centrally manage a refrigeration network defrost schedule(s)

To configure a defrost schedule choose 'Defrost' from the drop down list, having previously added a new schedule in the initial Schedule management page.

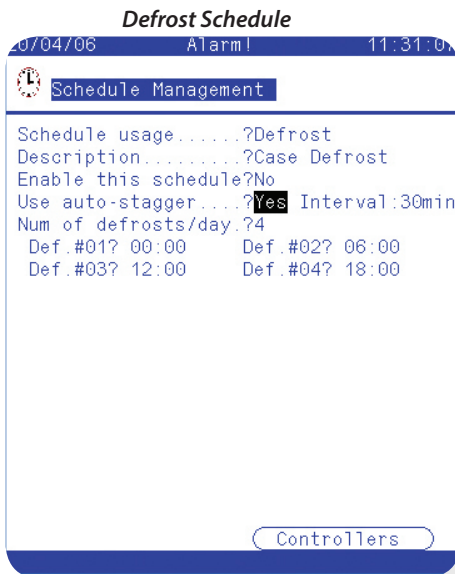

Give the defrost schedule an appropriate name

Choose to enable the schedule now or enable later

Use Auto-Stagger - If answered 'yes' an interval time should also be set

Auto Stagger is the function where the AK-SC255 automatically calculates the next interval times and fills the next suggested defrost times in. This feature is primarily used where multiple defrost schedules are required and simply saves the user time in configuration.

Use auto-stagger...?Yes Interval:15min

Num of defrosts/day.?4  
 Def.#01? 00:00 Def.#02? 06:00  
 Def.#03? 12:00 Def.#04? 18:00

*Auto Stagger auto fills in the next schedule times (incremental)*

Use auto-stagger...?Yes Interval:15min  
 Num of defrosts/day.?4  
 Def.#01? 00:15 Def.#02? 06:15  
 Def.#03? 12:15 Def.#04? 18:15

Once the defrost schedule(s) have been set, select the 'Controllers' button and assign the relevant controller(s).

### Night Setback

The night setback function schedule is used to send a command signal to selected controllers on the network and thus enabling the raising of the operational setpoints (for the duration of the night setback) and / or for Rail heat control. Controller devices that get added to the night setback schedule will raise their control setpoint to the allotted values set in the controller during the schedule times. The night setback schedule can be used to save operational energy, especially when the use of night blinds are used in the display cabinets.

Using the same principles as previously described, select 'Night setback' as the required schedule. The configuration of the Start and Stop times should be made - thus stipulating when the night setback should be in operation. Outside of these times the selected controllers will operate with their 'normal' setpoints.

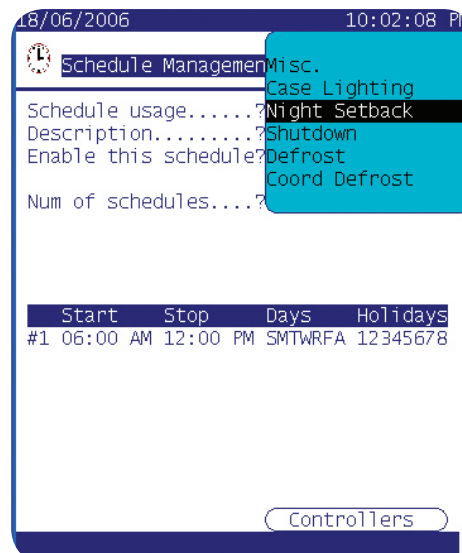

Using the dropdown list, select night setback schedule type

- Select Night Setback Schedule type
- Enter the time period that the setback will take effect
- Select the required days and / or holidays
- Select which controllers need to be affected by the schedule

### Coordinated Defrost

From the drop down list select Coord Defrost. As seen in the regular defrost schedule provide start / and frequency times.

The principle of operation for coordinated defrost is to ensure a group of evaporators synchronize the defrost cycles. This function would typically be used when there is a series of refrigeration sections without any partitions and the running of the units would be affected if one in the row were to be in defrost at the same time when the others are in refrigeration modes.

Please also consult the controller manual for further set up information and configuration

## Po Optimization (Rack suction pressure optimization)

The continuous and automatic optimization of the power pack suction pressure is performed by the central AK-SC255. At ALL TIMES the appliance temperature has the highest priority thus ensuring that food quality is NEVER compromised.

The pack suction (Po) pressure is optimized in accordance with the refrigeration demand, taking into account short-term changes (day/night setback) and long-term effects (seasonal/weather changes).

### Theory of operation

- 1/ The AK-SC255 receives operating information from each controller connected on the network.
- 2/ From the data received the AK-SC255 will identify which evaporator controller is under the heaviest load (the one that has to work the hardest to maintain temperature)
- 3/ The AK-SC255 then sends control signals to the Rack system to optimize the running suction pressure. As the Rack suction pressure is allowed to increase the AK-SC255 monitors the complete network and ensures that the refrigerating system as a whole is stable. This then is a continuous function that once set runs automatically and ensures the refrigeration system is running to the best conditions.



### Configuration of suction optimization

To configure the AK-SC255 system for rack optimization the system needs to recognise the Rack / Case 'relationship'. This relationship is formed when a Rack and associated evaporator controllers are configured.

Navigate to the Configuration / Refrigeration / Rack / Suction Info menu.

- Select the drop down list to highlight Dynamic
- Fill in the remaining questions as to max pressure, defrost delay etc.
- Page down to complete Rack Optimization setup
- Navigate to the Rack / Evaporators / Suction / Generic Setup page
- Ensure (auto set to 'yes') that case controller is included in optimization function - change if required

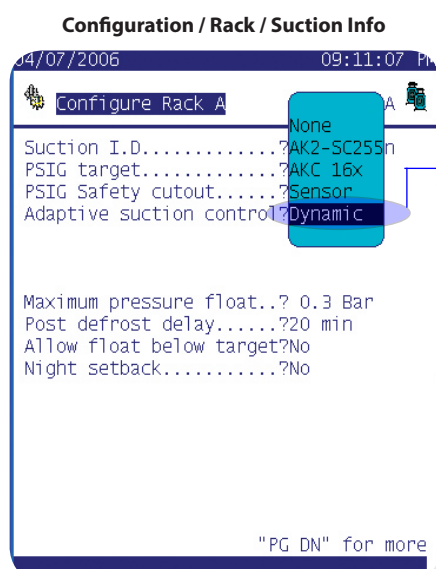

Under Rack configuration (suction info) define the Adaptive Suction Control as Dynamic

- Select Max pressure
- Defrost Delay
- Float below target
- Night setback

As default the Generic controller is included in the optimization function.

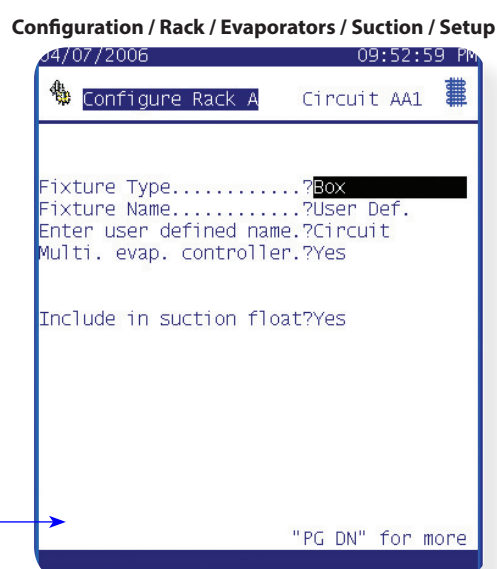

## Viewing status & performance of Po Optimization

Subsequent to setting up the Po Optimization the status and running conditions can be viewed. At a quick glance the configured evaporators can be seen if the Po Optimization is 'floating up' or if the system is satisfied.

### Dynamic Float

From the Main Menu select 'Refrigeration' and then the relevant Rack. From the resulting Rack menu screen select Evaporators. The list of circuit Evaporator devices will then be listed, press the 'Dynamic Float' button and select the appropriate suction group.

Selecting the relevant suction group will bring up the Rack Optimization Graph screen. This 24 hr. graph screen is designed to indicate which evaporator is under the most load and is continually updating. Any resulting pack pressure float will be seen in this menu and the target evaporator that is declared under the heaviest load will show a \* beside the description. The upper bar indicates the total time (over the 24 hr. period) that floating of the pack pressure has occurred.

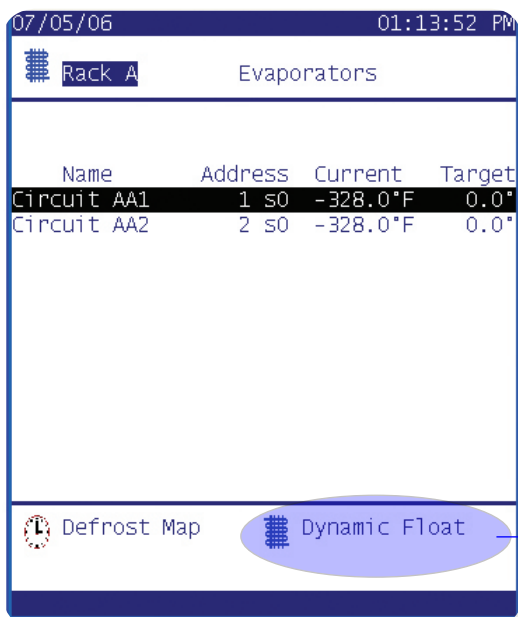

Use the Dynamic Suction Control graph page to reveal which current evaporator is under the heaviest load (indicated by a \*). The bars represent the duration of time (Hours & minutes) that each case has been operating outside of its normal temperature range and declared the most loaded case. If the \* is displayed next to the line 'Floating Up' then all cases are satisfied.

See the amount of pressure float by observing the 'Adjust suction by' line

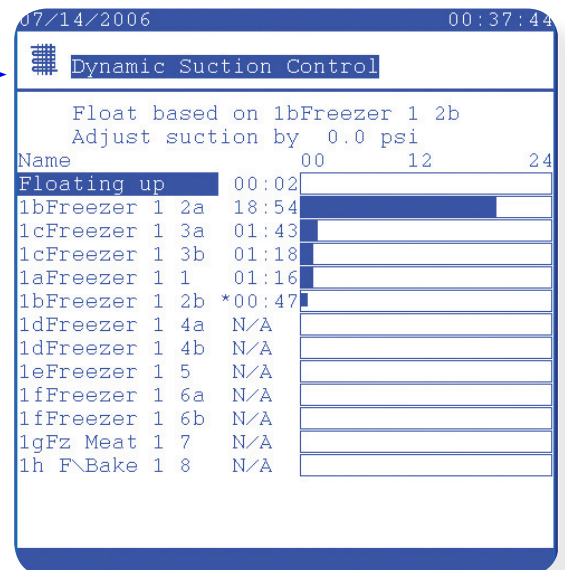

Optimization status graph

## Lighting Control Configuration

### Lighting

The Lighting feature in the AK-SC255 (*Licence required*) allows for the efficient control of various lighting applications. Lighting control is performed via the AK-SC255 itself (via Board & Points), Square D PowerLink®, Siemens or Cutler-Hammer® panels via data communications. There are three main steps in lighting configuration namely;

(1) Config Lighting Zones

(2) Config Board & Points

(3) Config Lighting Alarms

#### (1) Config Lighting Zones

From the **Main Menu** select 'Configuration' and then '**Lighting**'. A simple lighting menu appears that shows the Lighting Zones, Board & Point and Alarms icons. Select Lighting zones from the menu to configure the required lighting zones.

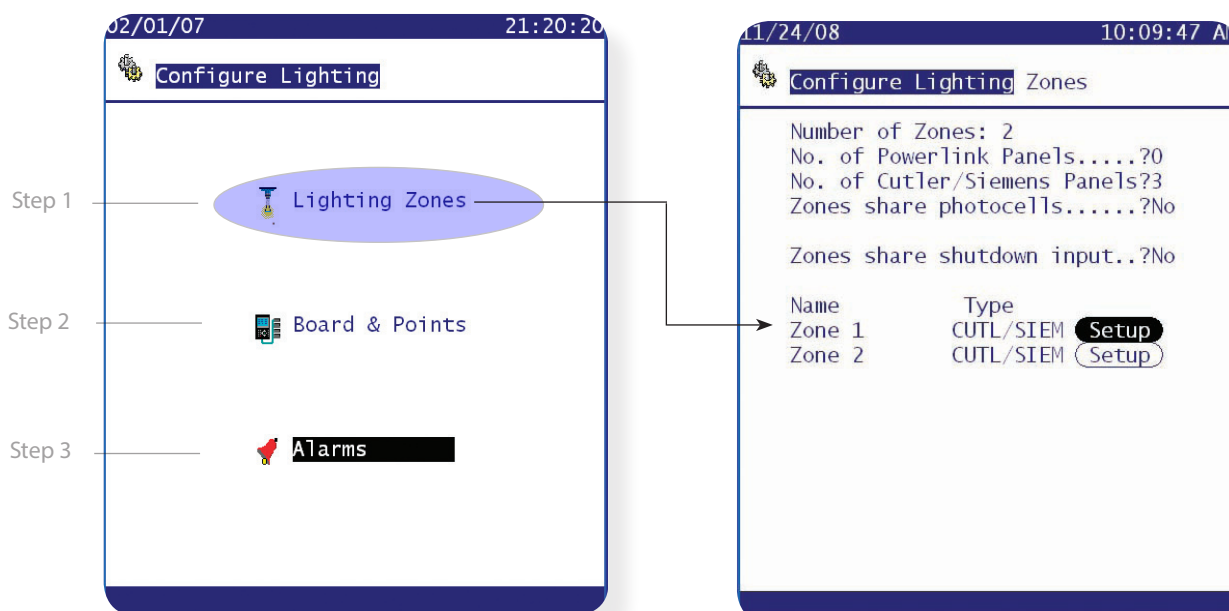

The Configure Lighting zone screen consists of the following areas - complete these areas to start the lighting configuration.

<b>Number of Zones</b>	(0 to 30) The number of lighting zones to be configured on one AK-SC255.
<b>No. of Powerlink Panels</b>	(0 to 5) The number of Square D Powerlink® lighting panels to be configured. The AK-SC255 currently supports both AS and G3 versions of Square D Powerlink panels.
<b>No. of Cutler-Hammer / Siemens</b>	(0 to 5) The number of Cutler-Hammer Pow-R-Line C™ / Siemens P1 Switchboard lighting panels to be configured.
<b>Zones share photocells (inside)</b>	(List box: Yes, No) Whether or not multiple photocells are to be shared. Number of photocells (0 to 8). (Appears only if photocell sharing is enabled by a Yes answer to the previous question).
<b>Name</b>	The name of the zone as established when Setup screen is entered.
<b>Type</b>	(List box selections:) <b>AK2-SC 255:</b> Zone is controlled by a relay output (digital output) on the I/O network. <b>PWRLK:</b> Zone is controlled by a breaker or group of breakers in a Square D Powerlink® lighting panel. <b>CUTLR:</b> Zone is controlled by a breaker or group of breakers in a Cutler-Hammer Pow-R-Line C™

Once the initial information has been completed on the 'Configure Lighting Zone' page, the lighting zones can now be setup.

The first page of the setup screen is shown in the illustrations below. On the left for an inside photocell, and on the right for an outside photocell. In the screen on the left, a user-defined zone name has been chosen. On the right, one of the listed zone names has been chosen.

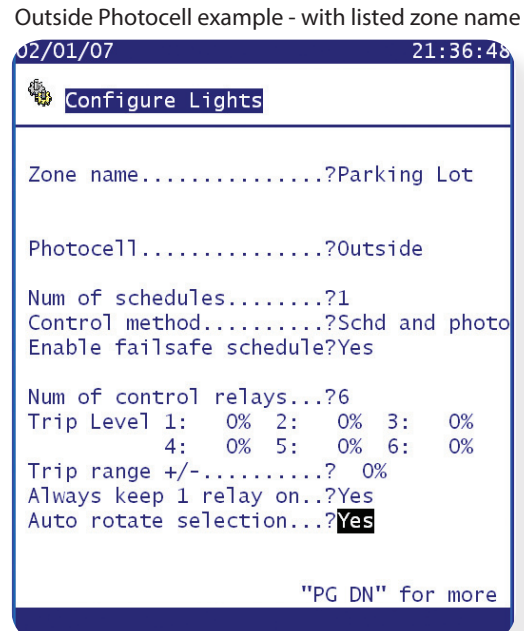
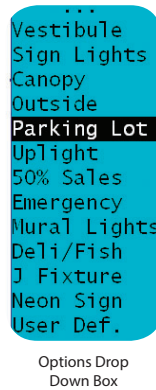
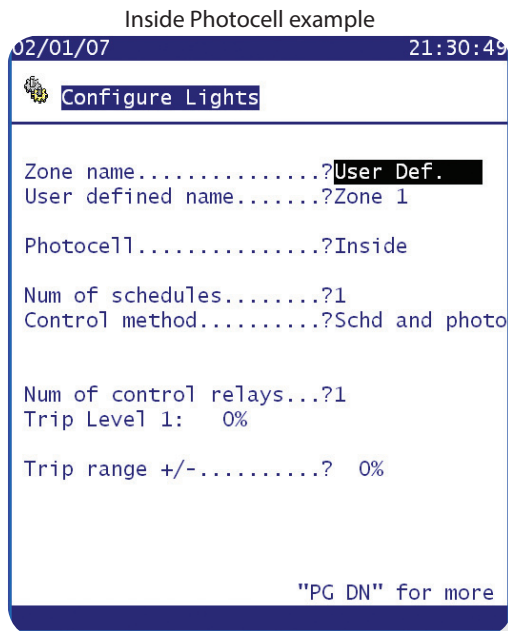

- Zone name** (List box: ) A great variety of typical names are included in the box that pops up, plus "User Def." that allows the next line.
- User defined name** (Label box; any 11 characters)
- Photocell** (List box:)  
**Inside:** The point's photocell(s) is indoors.  
**Outside:** A single photocell is located outdoors.  
**None:** This point has no photocell.
- Control sensor (seen if Photocells shared is selected to 'yes')** (List box:)  
**Min:** The lowest-reading photocell at any given time will be used as the control sensor.  
**Max:** The highest-reading photocell at any given time will be used as the control sensor.  
**Average:** All photocells are averaged, and the average value is used as the control sensor value.  
**Photocell ID#1 (etc.):** If any specific photocell is selected , its value alone will be used as the control sensor value.
- Num of schedules** (0 to 8) The number of schedules for this point.
- Control method** (List box:)  
**Schd and photo:** For this point to be on, two conditions have to be satisfied: (1) the schedule must be true; and (2) the photocell must be above trip level. Once those two conditions are satisfied, the pre-delay timer will start.  
**Schd or photo:** For this point to be on, either of two conditions must be satisfied: (1) the schedule must be true; or (2) the photocell must be above trip level. Once one of those two conditions is satisfied, the pre-delay timer will start.
- Enable failsafe schedule** (List box: Yes, No) Whether or not a schedule will "back up" in case the photocell fails.  
**Time on** (Time of day field) The time at which the pre-delay timer for outside lights will start without the photocell having tripped.  
**Time off** (Time of day field) The time at which the post-delay timer for the outside lights will start without the photocell rising above trip level.
- Num of control relays** (0 to 6) The number of relays controlled by the lighting point.
- Trip Level** (0 to 100) The level at which the photocell condition will be true and act to turn the lights on. (If multiple relays are configured, there will be one trip level per relay.)
- Trip range +/-** (0 to 100) The number of percent from night to day.

**Always keep 1 relay on** (List box: Yes, No) (Appears only when there is more than one control relay) Whether or not one relay will always be on.

**Auto rotate selection** (List box: Yes, No) Whether or not the one relay kept on will rotate among all the relays configured. Rotation takes place so that the same relay is not used when the zone cycles off.

"PG DN" - Setup Page 2 (Lighting Configuration)

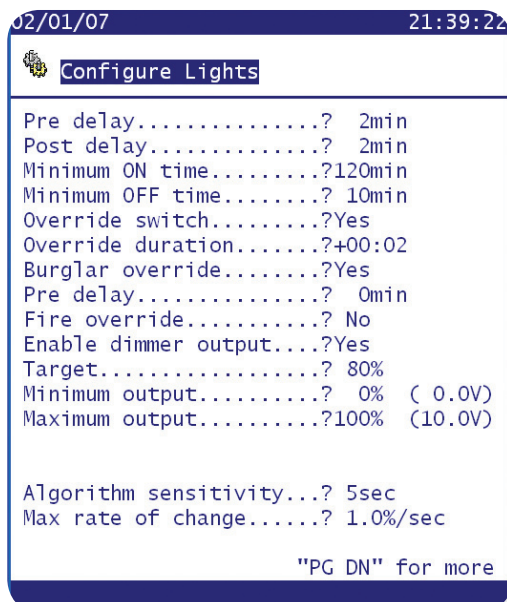

Configure Lighting - Setup Page 2

**Pre delay** (0 to 120) When lights are off, the number of minutes that the lighting condition must be satisfied before lights will be turned on.

**Post delay** (0 to 120) When lights are on, the number of minutes that the lighting condition must be false before lights will be turned off.

**Minimum ON time** (0 to 255) When lights are turned on, the number of minutes that they must remain on before being turned off.

**Minimum OFF time** (0 to 255) When lights are turned off, the number of minutes that they must remain off before being turned on.

**Override switch** (List box: Yes, No) Whether or not there is an override switch assigned to the zone.

**Override duration** (Time field: 00:00 to 23:59) The duration of an override when the override switch is used.

**Burglar override** (List box: Yes, No) When this zone's lights are turned off, whether they are to be turned on when a monitored burglar alarm is sensed.

**Pre delay** (0 to 600) When this zone's lights are off and a burglar override is called for, the number of minutes delay before the zone is turned on.

**Fire override** (List box: Yes, No) When this zone's lights are turned off, whether they are to be turned on when a monitored fire alarm is sensed. There is no pre-delay for fire alarms.

**Enable dimmer output** (List box: Yes, No) Whether or not a dimmer variable output will be controlled.

**Target** (0 to 100) The photocell level that the controller will seek to maintain by operation of the dimmer.

**Minimum output** (0 to 100) The minimum dimmer level

**Maximum output** (0 to 100) The maximum dimmer level

**Reaction time** (List box: Slowest, Slow, Normal, Fast, Fastest) The relative sensitivity of control to changes in photocell level.

**Algorithm Sensitivity**

(Becomes active when Dimmer output set to yes)

(1-15 sec) The frequency (in sec) how fast the algorithm re-calculates a voltage output

**Max rate of change**

Percent at which the output changes per sec.

"PG DN" - Setup Page 3 (Lighting Configuration - Schedules)

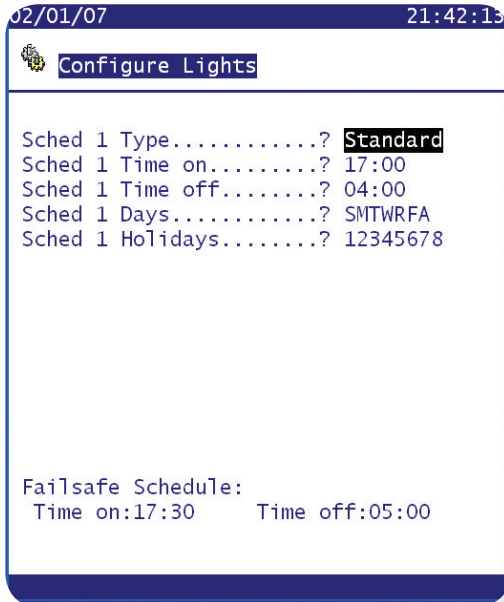

**Sched 1 Type**

(Standard or Relative)

Select the type of Schedule - A standard type simply follows the set times. Relative is based on the store operating hours (found in Main Menu / Store Info / Operating Hours)

**Time on, Time off, Days, Holidays**

**Fail safe Schedule**

To ensure lighting energizes under photocell / light equipment failure enter failsafe on & off times

**(2) Configure Board & Points**

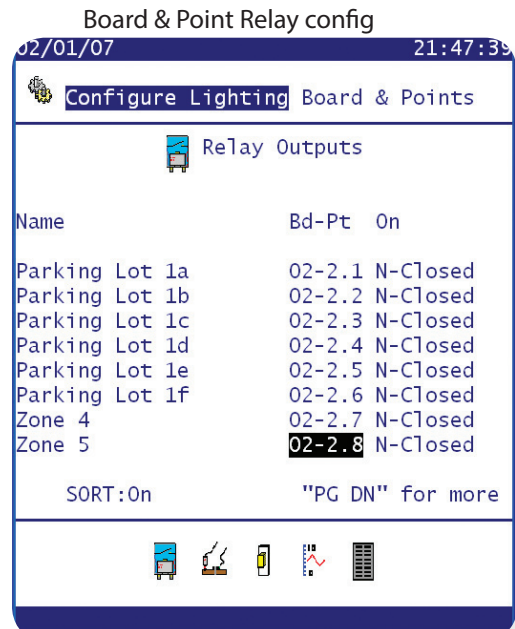
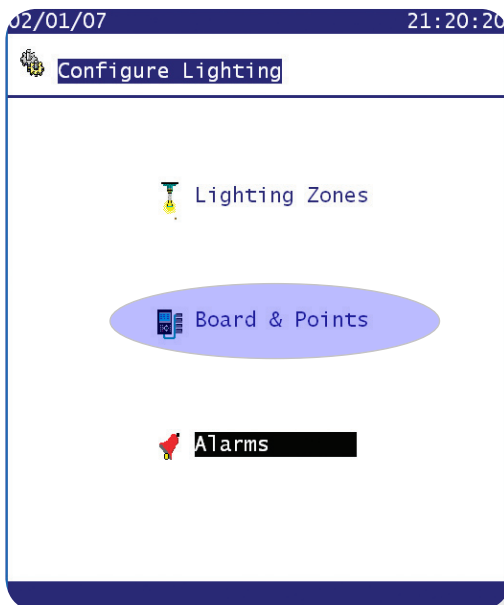

Dependent on how the previous Lighting Zone setup pages have been configured the Board & Point screen will reflect these settings. In the above example the initial **Relay page** shows 6 'Parking Lot' Zones - as per configured in the Lighting Zone setup. The Board & Point Input / Outputs that control these zones now need to be programmed.

Board & Point programming can take the form of three variants - AK2 I/O, Controller, Akcess. **AK2 I/O** is the most widely used form of I/O and the example above shows the programming of AK2 I/O module address 2.



Further details on programming Board & Points can be found in the appendix section.



Next select the Sensor Input icon and ensure all relevant configuration information is set. Continue to check the remaining I/O pages via the icons at the bottom of the screen.

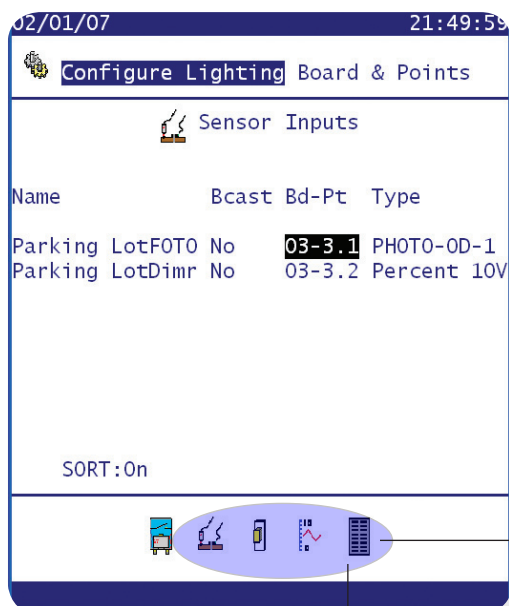

Check & configure the remaining Input / Output areas of the Board & Point lighting

### Powerlink configuration

Configuration of Powerlink lighting zones is the same as for the SC 255 zones just discussed, except that the question 'Number of control relays' is replaced with Number of control points. These panels also require board and point setup and initialization.

### Cutler-Hammer configuration

Configuration of Powerlink lighting zones configuration is the same as for the SC 255 zones just discussed, except that the question 'Number of control relays' is replaced with Number of control points. These panels also require board and point setup and initialization.

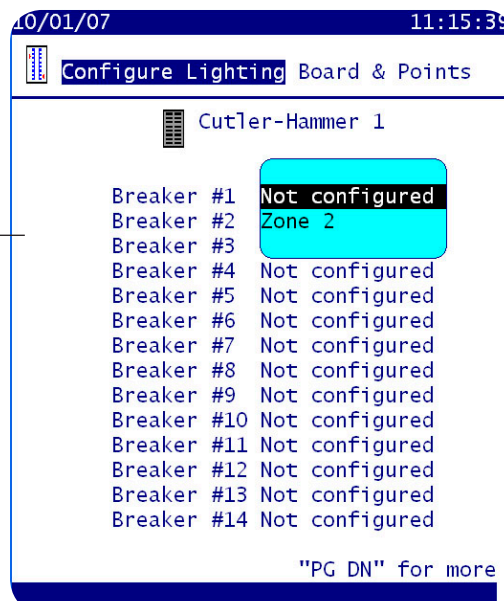
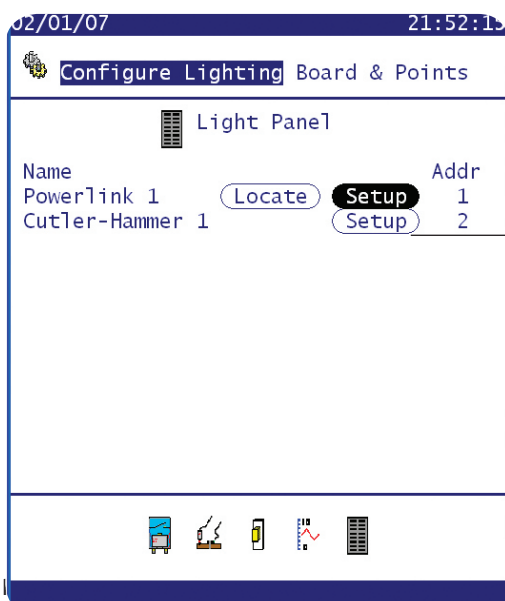

### Cutler-Hammer board & point configuration

From the 'Configure Lighting / Board & Points' screen select the **Setup** button, the setup screen will appear as at right above. For each breaker, there is a list box with the names of the zone names that can be assigned to that breaker. Select the appropriate zone name for each configured breaker, and setup is complete. **Return to the Configure Lighting page to set any Alarm points needed.**

#### Locate procedure

Powerlink panels require that you put the cursor on the Locate field and press enter. A popup box will appear on the screen instructing you to press the service pin on the breaker panel. You will have a few minutes to do this. Successful location will be indicated by a message in the bar at the bottom of the screen.

Cutler-Hammer panels do not require the locate procedure.

## Siemens P1 series lighting panel control

### Hardware Configuration

This section introduces the hardware connections between Siemens P1 series lighting panel with i-3 I/O controller (Siemens P1) and Danfoss AK2-SC 255. Siemens P1 is used as the lighting panel controller and connected to the Modbus interface of AK-SC255. Currently, one AK-SC255 allows a max of five such panels to be configured. **The Siemens P1 panel address is set with Siemens panel configuration software tool supported by Siemens (Free download from Siemens Web site).** The default Modbus device address for Siemens P1 is 126 and serial settings are 38400 baud, no parity, 8-bit data, 1 stop bit. The supported address of AK-SC255 is from 0 to 120 - use Siemens configuration tool to set appropriate address. Each panel has 42 breakers. The connection between AK-SC255 and Siemens P1 is shown in the Figure 1.

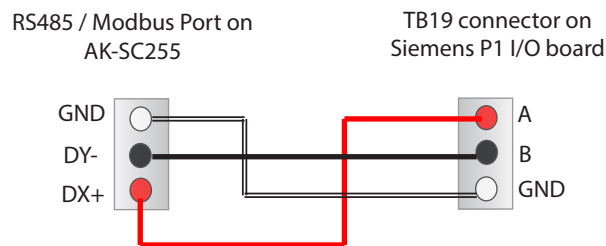

Figure 1

The configuration of the Siemens P1 lighting board includes the following steps, which are introduced in this section.

### Configuration of the lighting zones

The lighting zones are built to control multiple groups of the lighting breakers. AK2-SC 255 supports at most 30 lighting zones. Users can configure zone for each individual breaker or group of breakers. Starting from the selection of "Configuration" from the main menu, users can select the "Lighting" option to setup the lighting zones. On this screen, the number of Cutler-Hammer or Siemens lighting panel and number of zones can be configured. Refer to the screenshot in Figure 2 for this step.

For each zone, users can setup the type of the lighting control panel. For Cutler-Hammer or Siemens panel, please select "CUTL/SIEM" from the drop list. Then click "Setup" button, select the name of the zone and other control options. Use "PG DN" to go to more options. The last page will allow users to setup the lighting zone schedules. Refer to the screenshot in Figure 3 for this step.

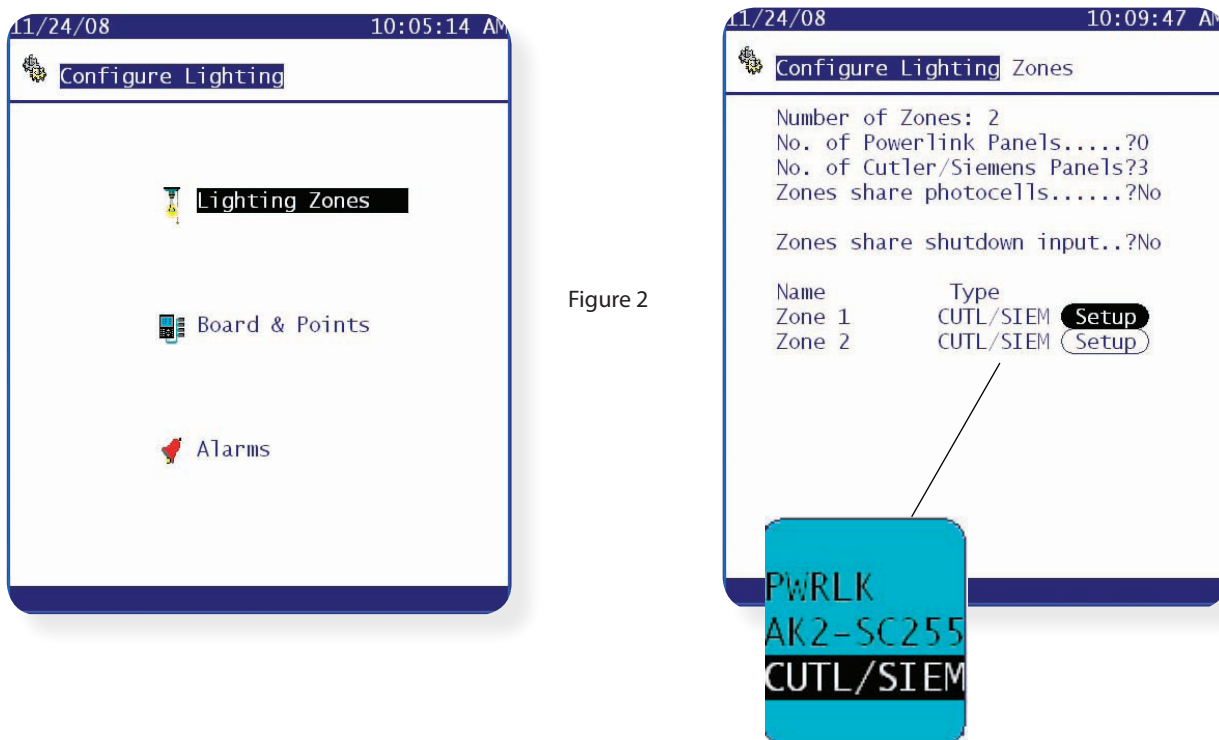

Figure 2

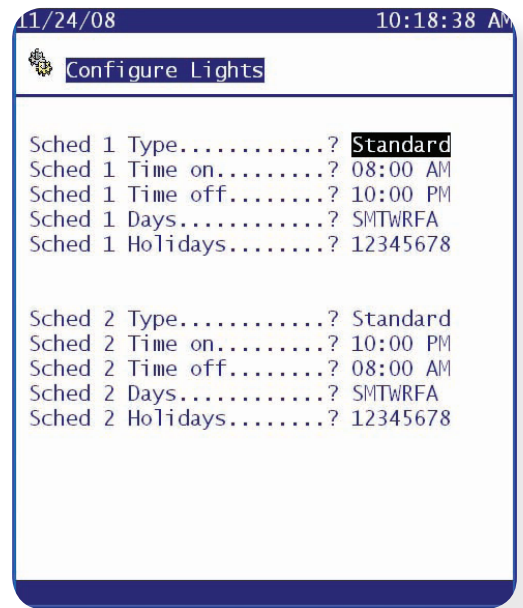
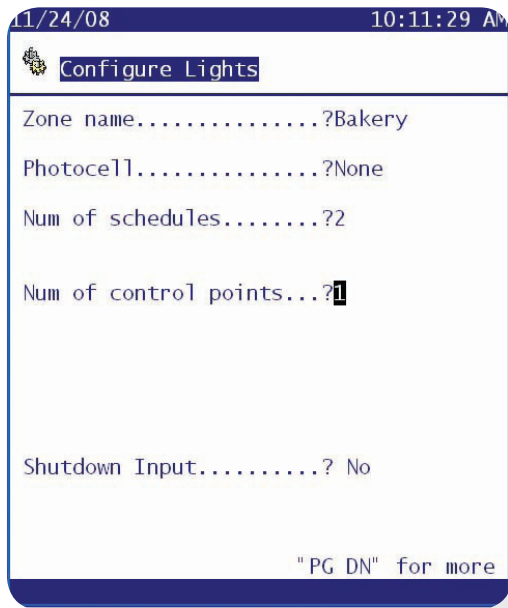

Figure 3

**Configuration of the Board & Points**

This section will setup the address of each lighting control panel and the lighting zone of each breaker. After the lighting zones and schedules are set up, go back to "Configure Lighting" menu to configure the "Boards and Points" of Siemens control panel boards. On this screen, navigate the cursor to the "light panel" icon on the rightmost at the bottom of the screen, and then press ENTER. We can see a list of the Cutler-Hammer/Siemens boards, the number of the boards in this list is the same as the number of lighting panels we configured in the first step. Here, users can input the names and addresses of the Siemens P1 boards. After the addresses are set up, select the setup button for each Siemens P1 board, a new screen will be shown to allow users to setup the zone for each breaker. If the breaker is not connected to the any lighting facilities, leave it as "Not configured".

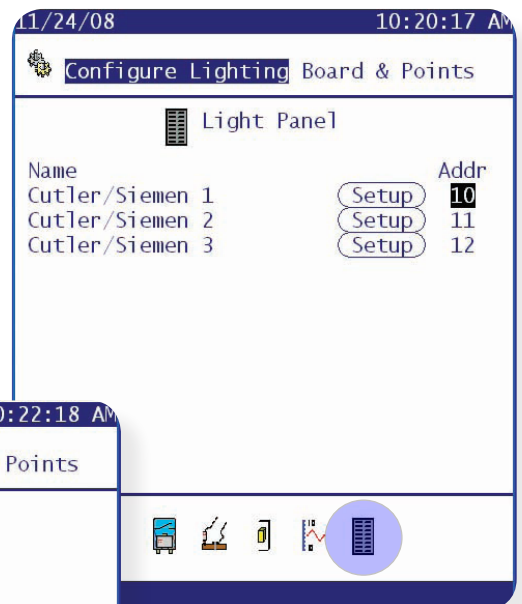
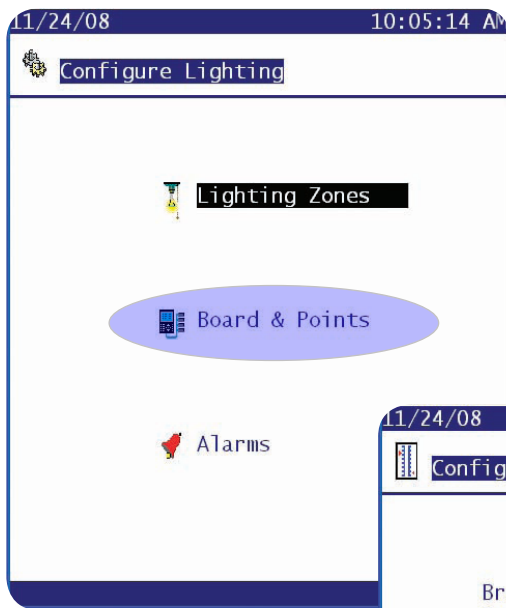
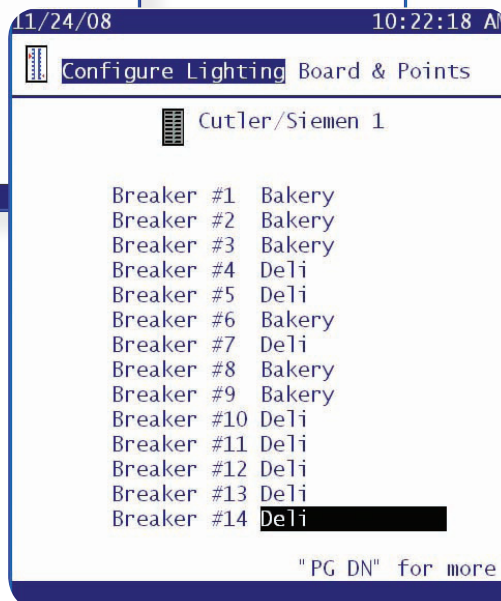

Figure 4



### Configuration of the Alarms

Users can also enable the alarm by configuring “Alarms” in the “Configure Lighting” menu. For each zone, users can disable or enable the alarms in different priority levels. This is shown in Figure 5.

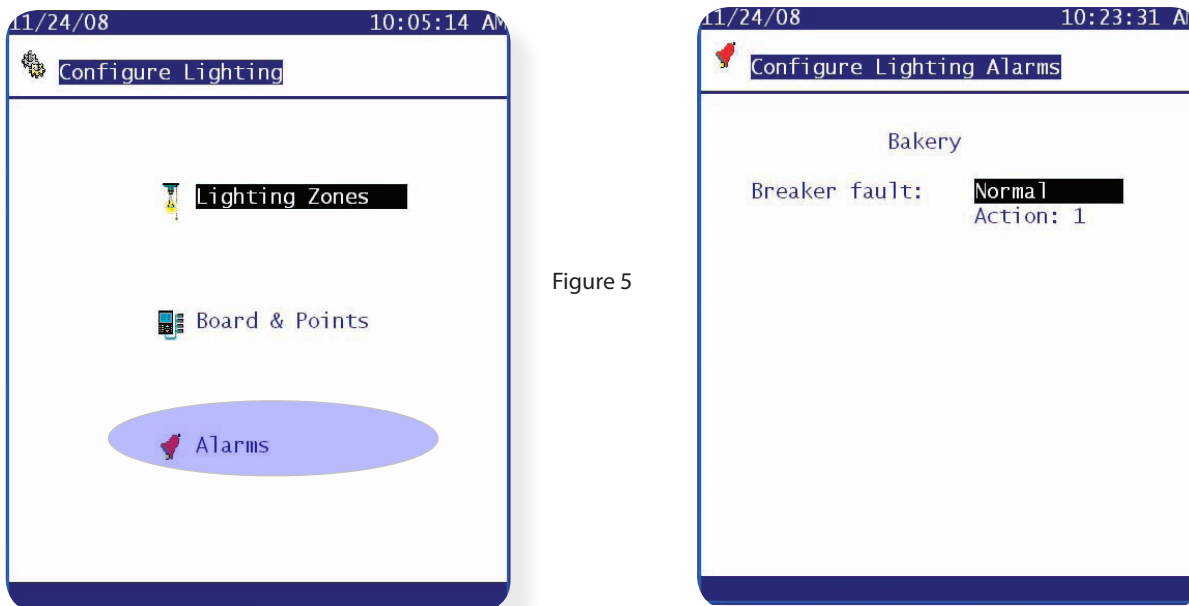

Figure 5

### Configuration of the Modbus Communication Channel

After the lighting panel is configured in the previous sections, we need to setup the Modbus communication channel.

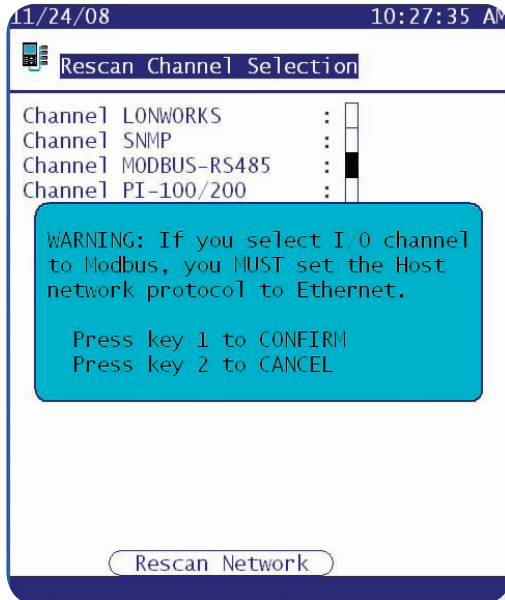

Figure 6

On the main menu, select “Communication”, then select “I/O Network”, I/O network status screen will be shown, move the cursor to “Rescan Channels” and press ENTER. Select “Channel MODBUS-RS485” check box and a warning box will appear in the center of the screen cautioning that if you select I/O channel to Modbus, you must set the Host network protocol to Ethernet. After press key 1 to confirm, the rescan channel selection menu will appear again with channel MODBUS-RS485 box checked as shown above. Choose “Rescan Network” to start the rescan process. The rescan process will scan the modbus communication network with the different configuration setup. Currently, there are four (4) different setups which need to be scanned. This rescan process will take about 2 to 3 minutes to finish. After the rescan finished, go back to the “I/O Network” menu and choose “List Nodes”, if the communication channel works fine, the Siemens P1 boards connected to this AK2-SC 255 unit should be appeared as “online”. At this point, the Siemens P1 boards are configured correctly.

## History (Parameter, food safety logging)

The AK-SC255 is capable of storing recorded data from devices and I/O on the network. Use the following steps to quickly set up and view stored data. It is recommended that if large amounts of data be stored at high frequencies, the use of a permanently connected PC running AKA65 software be deployed. The connected PC can be scheduled to extract and save system history, the AKA65 software also has greater graphing tools that enable deeper analysis of data and also the facility to export to spreadsheet formats.

First get authorized

Then navigate via the main menu to 'History' History

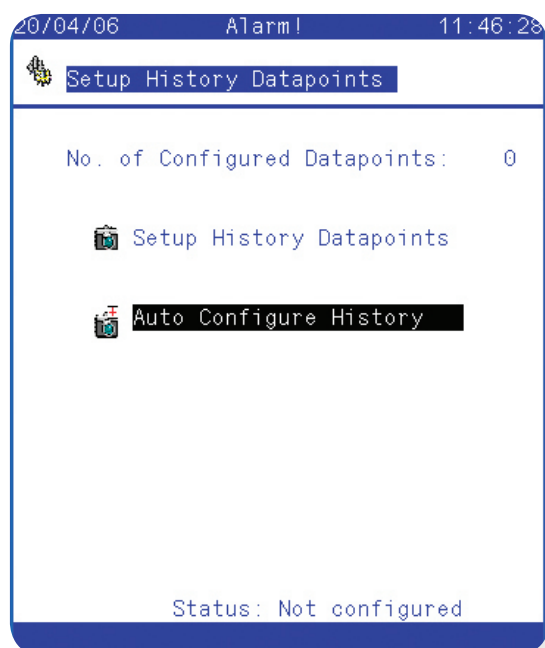

Select Configure History option

Two options are available on this screen;

**Setup History Datapoints** (manually define points)

**Auto Configure History** (factory pre set points to enable quick start logging. If the factory settings are not per requirements manual additions / alterations can be made post the auto configure setup.)

*Clear History Datapoints (may be visible if the system has pre defined points)*

Select Auto Configure History

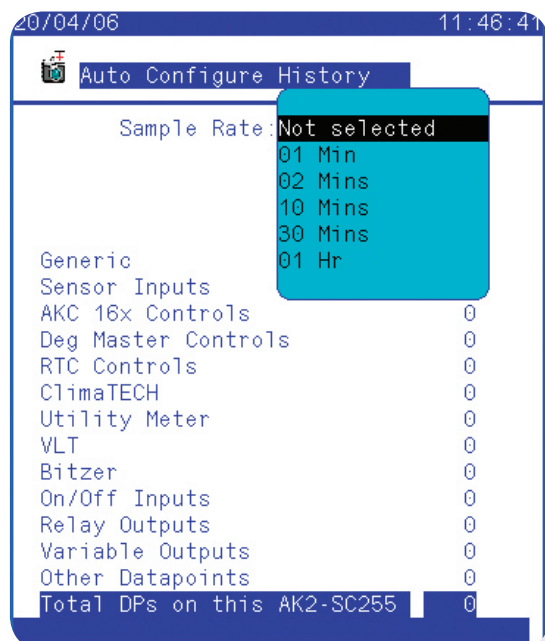

Next define the sample rate via the drop down box.

As part of this setup all previous configured history (if any) will be deleted. To proceed further the AK-SC255 will hold a question asking 'Do you want to Auto Configure...?' - Select **yes** to continue.

The total data points (DP's) that get used in the history will be displayed at the bottom of the screen. The AK-SC255 has a current capacity of 600 points. Exit once out of this screen.

To finalize the auto configure process, collection of history needs to be started. The screen that is now displayed will show a large button called 'Start History'. Press this button to activate the auto history collection. The status at the bottom of the screen will now show 'collecting'.

## History - Manual configuration

If the Auto history configuration is not sufficient for the application and additional / different points are needed, manual setup can be used.

From the Configuration page navigate to /History/Configure History.

Select the option 'Setup History Datapoints'

The Configure History page will now be shown. The AK-SC255 has many different variables it can log, thus the lower section of this screen will show various icons. In this example the term **'Other Controllers'** is used to describe EKC and AK2 controllers.

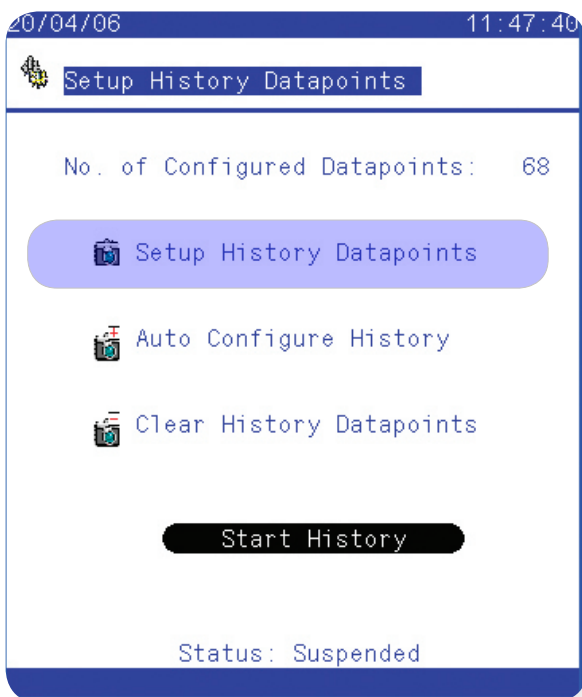

Select the 'Other Controllers' icon

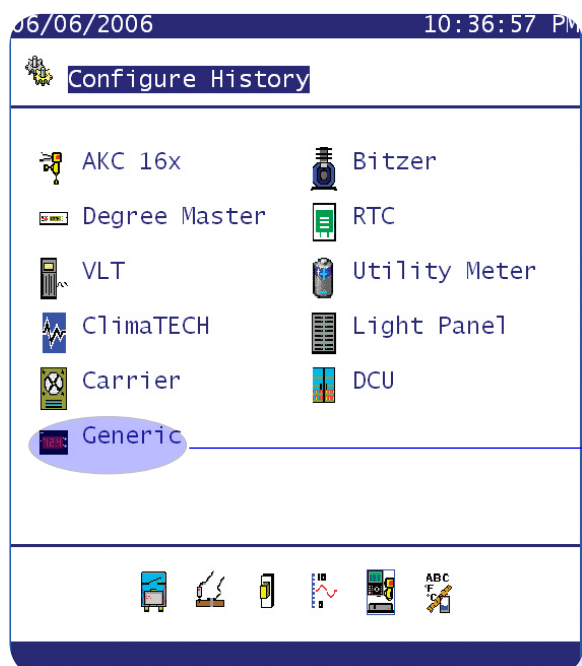

The screen now highlights various controller types.

To view EKC and AK2 controllers select **'Generic'**.

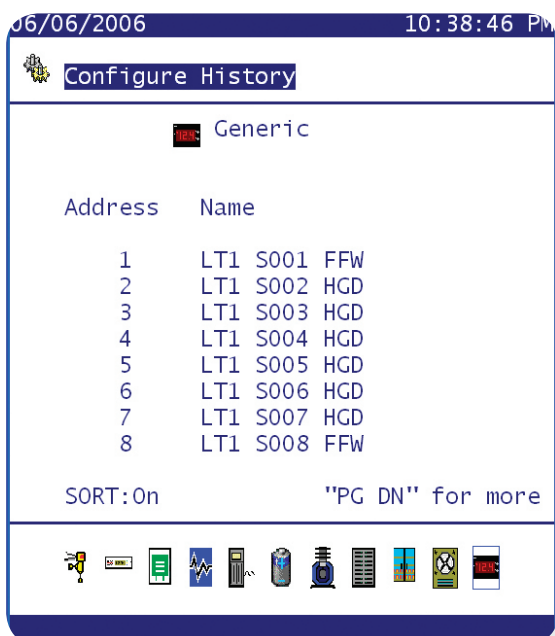

Having selected 'Generic' the available connected controllers will be displayed. The list will indicate the controllers net ID address and the description.

Use the Page Up & Page Down button (up / down arrow on PC) to scroll through this list.

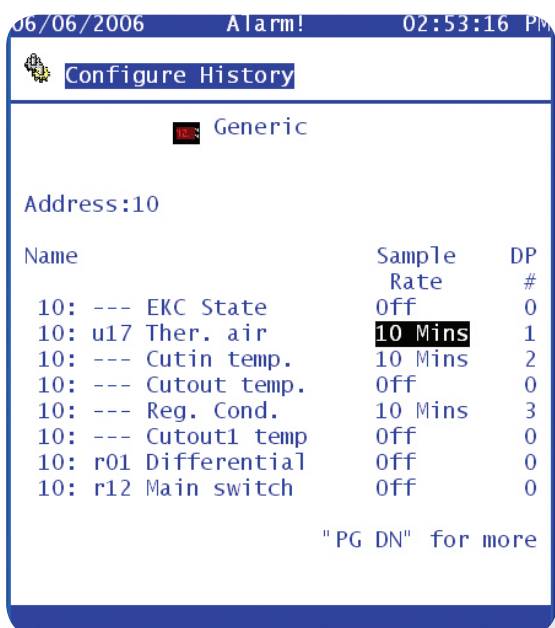

To make a change in any one of the controllers listed, highlight the device and press enter.

The screen now shows the selected controller and all the available parameters that can be changed. Scroll down the list of parameters and highlight the item that requires change.

Use the Edit key (right mouse click on PC) to bring up selectable sample rates - choose sample rate and enter. Note after this change the Data point number increases highlighting that one available database point has been taken up.

Exit out of the screen(s)

**Start History**

**i** Ensure that the status of the history is set to 'Collecting' and not 'Suspended'. Always select 'Start History' to ensure logging

### The Operations of AK2-SC 255 Lighting Control

In this section, the basic operations of the AK2-SC 255 lighting control are introduced.

If configured, all breakers on the light panel would be controlled by AK2-SC 255 lighting zone and schedules. The status of the zones and breakers would be shown in the main menu and under "Lighting Service" submenu. Refer to Figure 7, the lighting zone and light panel status is shown.

There are 4 possible breaker statuses: "Auto On", "Auto Off", "Manual On" and "Manual Off". "Auto" mode means the breaker is controlled based on the preset zone and schedules. "Manual" mode refers to the override control. The breakers can be overridden from "Auto" to "Manual" and vice versa in the last screen. There might be a delay up to 10 to 20 seconds to change the breakers to the desired status.

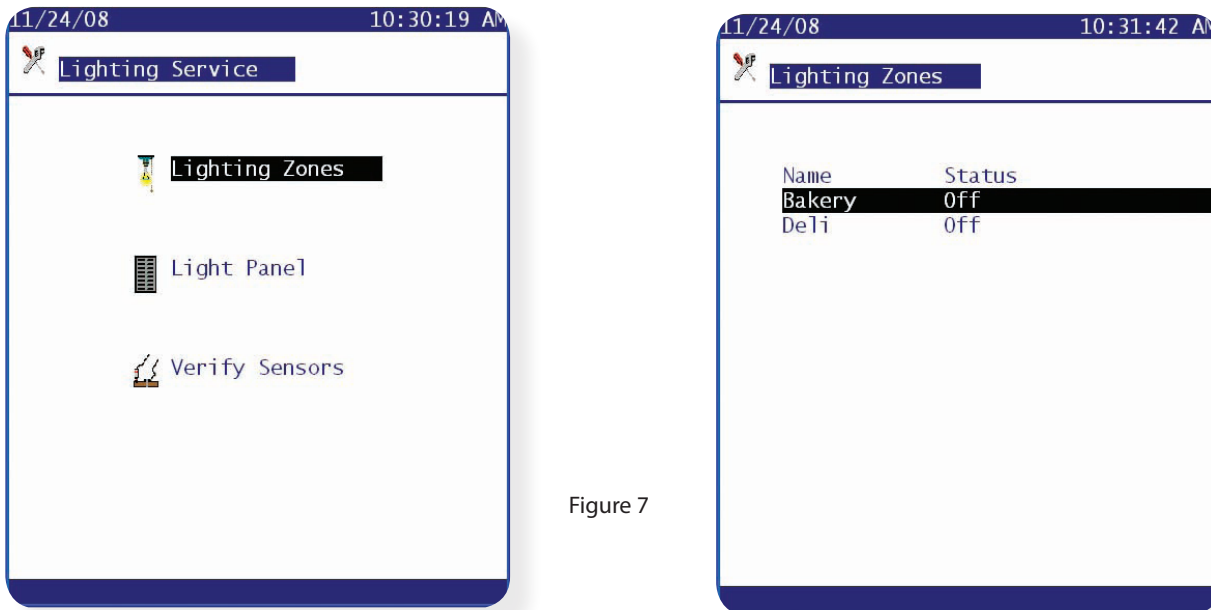
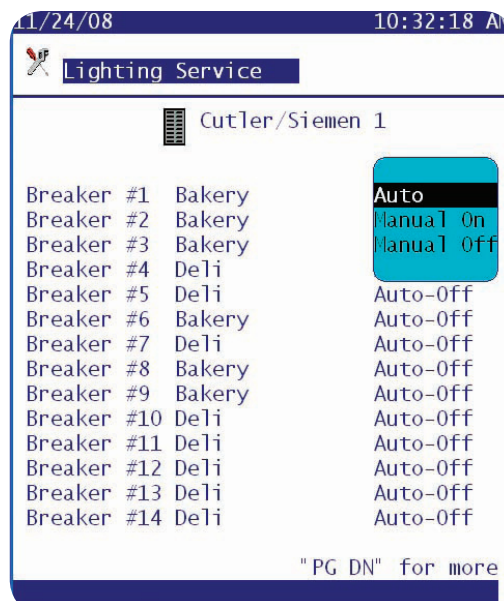

Figure 7





## Distech EC-Stat (Digital HVAC thermostat with AK-SC255 support)

The Distech EC-Stat range of controls are designed for single and multi-stage control of heating / cooling equipment such as rooftop and heat pump units. The following instructions provide guidance on how to install an EC-Stat so that it can be accessed via the AK-SC255. Like most devices in the HVAC market the EC-Stat communicates over LonWorks® FTT10 protocol, make sure correct wiring practices are used and install TP78 - FTT10 bridge to ensure correct communications.

### Identifying the correct EC-Stat version

Distech have released several versions of the EC-Stat and the latest devices look very similar from the outside, to identify the appropriate model remove the outer case and check the PCB layout - see below for details:

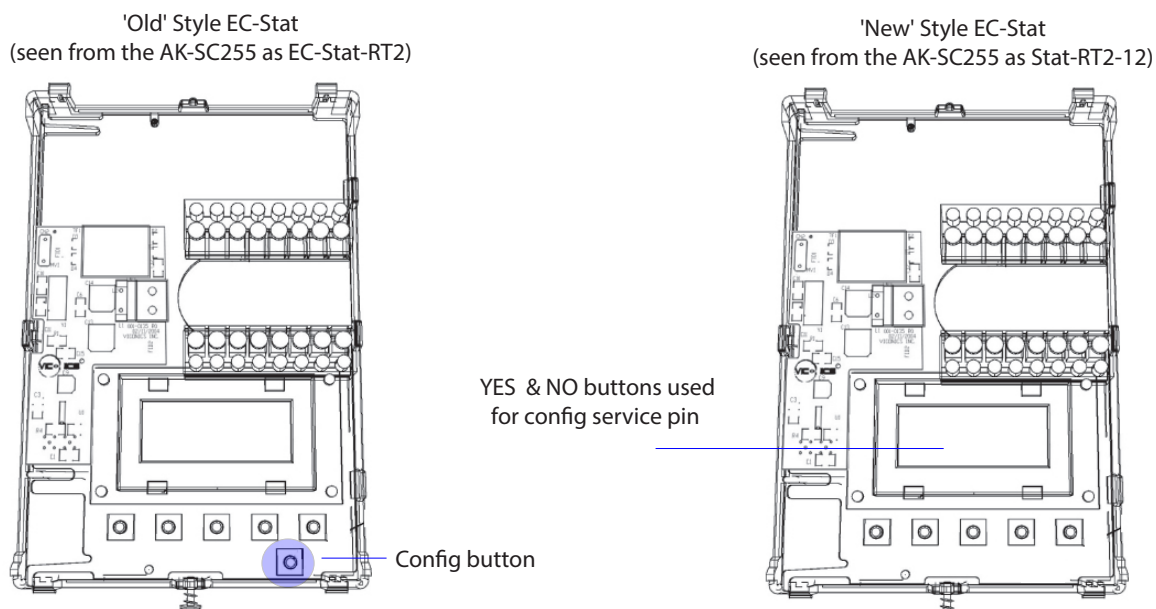

### Connection to AK-SC255

Install a TP78 - FTT10 Bridge (084B2252) just down stream from the AK-SC255 unit (recommend max 6.5 feet). Ensure that the input & output connections on the bridge have 120 Ohm resistors fitted. Connect the network cable to all the EC-Stat units - recommend point to point (Daisy chain) topology.

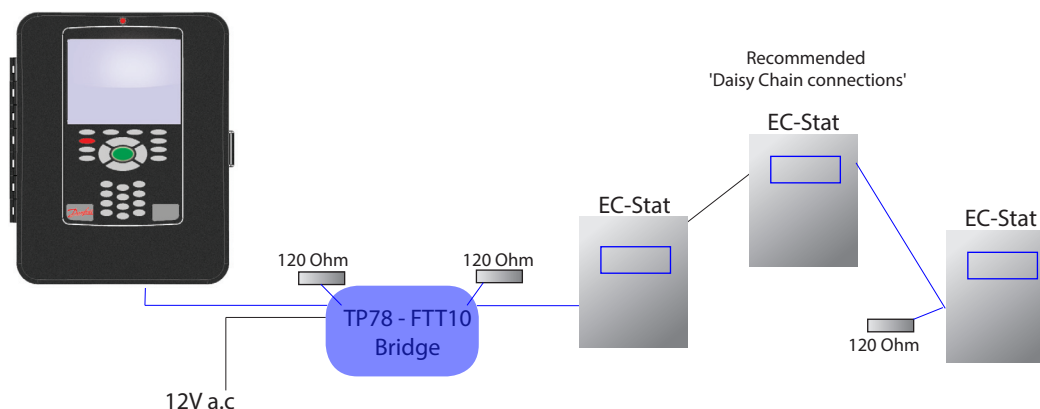

Once all network connections have been made and power has been applied to all devices the EC-Stats the process of commissioning on the AK-SC255 can begin.

From the Main Menu / Configuration screen, enter the HVAC menu.

Enter the number of HVAC units (EC-Stats) required, enter appropriate values (if required) for the remaining questions.

Next, via the drop down list, select '**Generic**' as the device type. A more descriptive name can also be applied to the name field.

Select the **Setup** button to enter the configuration pages for the EC-Stat. Select the appropriate device file for the EC-Stat, via the drop down list. In this example the current EC-Stat model has been matched (STAT-RT2-12-001x).

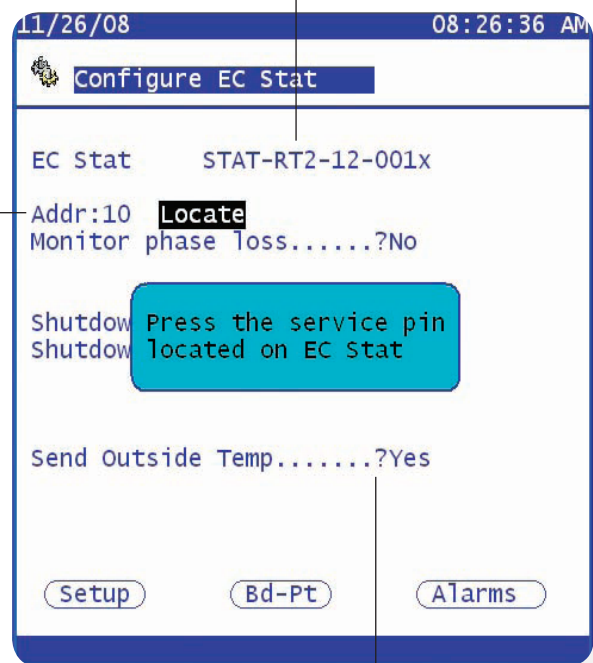
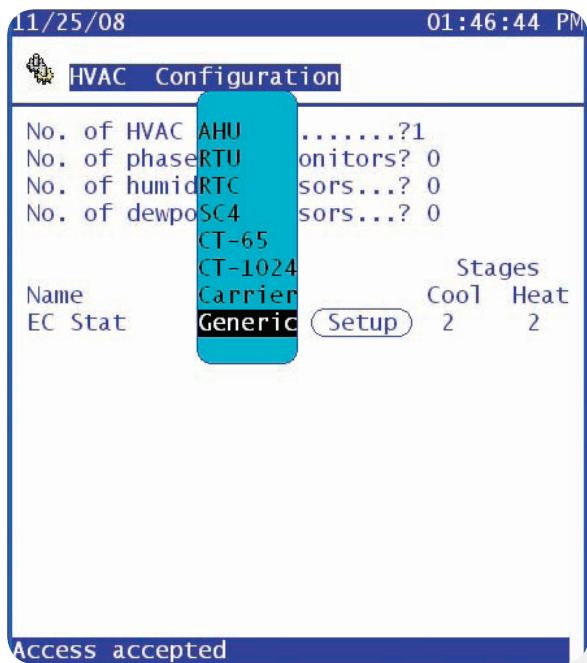

Once the correct device file has been selected an address (used by the EC-Stat) needs to be entered. In this example address 10 was entered. It is also common for the outside temperature to be made available in the (AK-SC255) system - Select **yes** (requires a rescan)

Once the address has been entered in the AK-SC255, the EC-Stat needs to send a 'Service PIN' over the network in order to accept this address. Press the **Locate** button and the AK-SC255 will display an information screen to request the service pin on the EC-Stat needs activating. In the new style EC-Stats (Model type RT2 -12) the service pin is activated via the 'Yes & No' buttons - See below for more information;

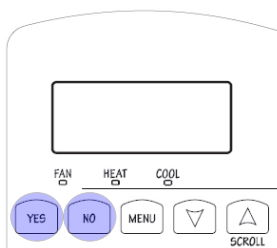

New style RT2-12 Service Pin: Press & hold the YES & NO buttons on the device simultaneously, for about 5 to 10 seconds, this will broadcast the Neuron ID on the Lonworks network.

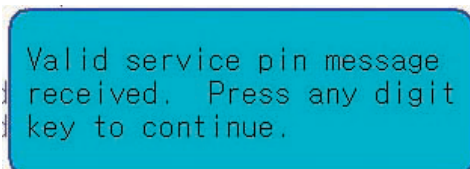

Once the service pin has been accepted the AK-SC255 will display a valid service pin message.

Once the EC-Stat has been logged on to the AK-SC255 any accessible menus are now available.

The setup menu allows access to key parameters in the EC-Stat - Configure as per site requirements. Typical settings to pay attention to is the Max Heat & Min Cool - These set the limits to which the EC-Stat can operate within. The min time heat/cool setting prevents short cycling & the Max heat / cool cycles also prevents cycling. Consult Distech EC-Stat documentation (supplied with product) for full descriptions - (Hardware Installation guide EC-STAT -RT/EC-STAT-HP 05DI-HISTRTH-22)

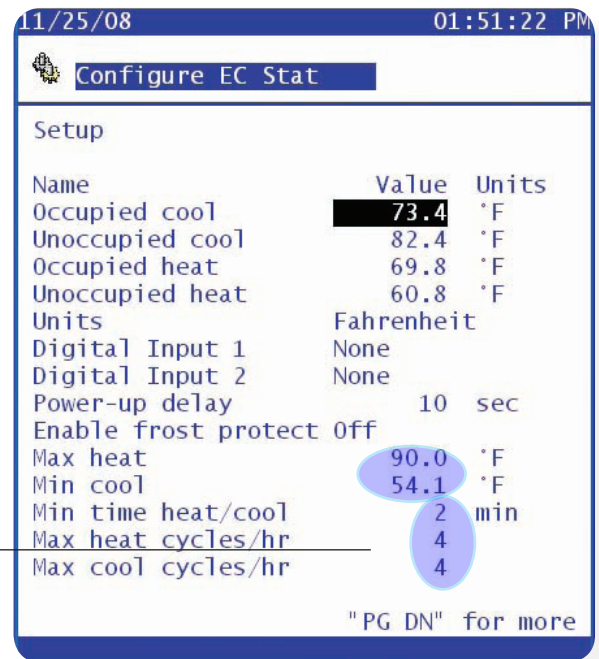
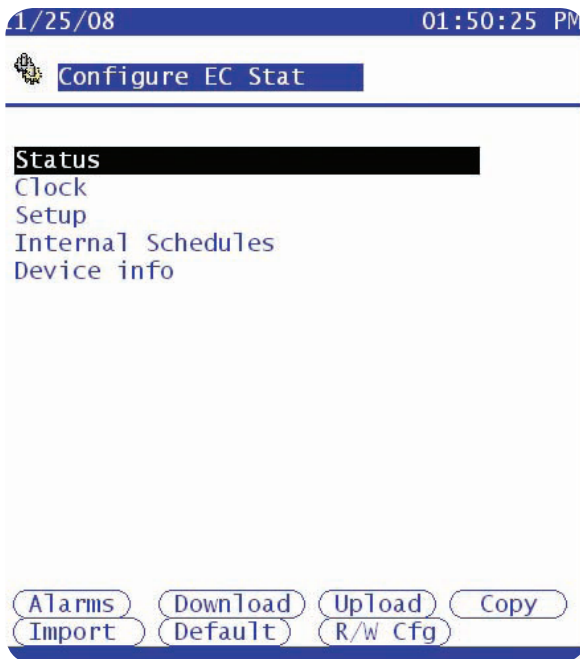

Page Down to access further configuration menus.

The keypad on the local EC-Stat can be locked out via the AK-SC255 - select Level 2 to lock the all settings, except the clock. Use Level 0 to allow full access and Level 1 for partial access.

Once configured the operational values can be seen in the AK-SC255. From the **Main menu** select **HVAC**, select the HVAC unit and the status screen will appear.

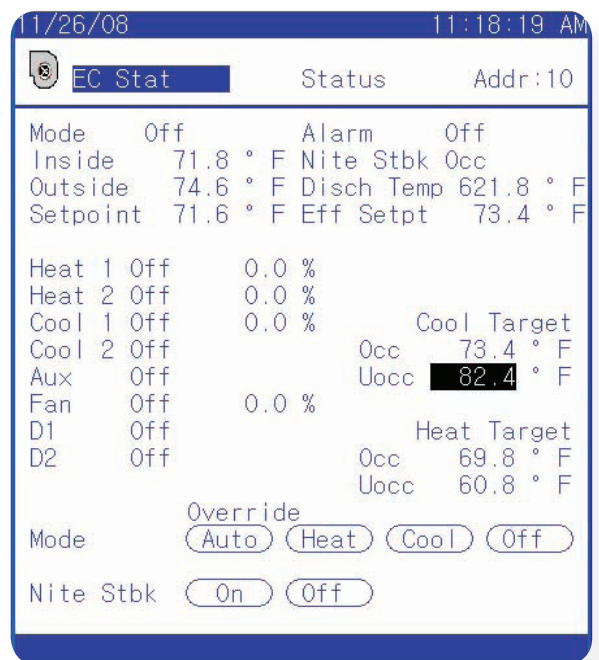
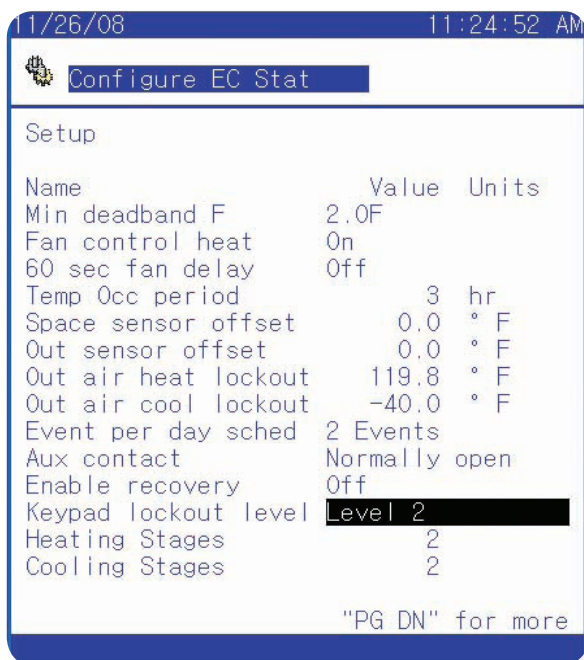

## Lennox HVAC controller support

Version 02\_101 and above offers support for the Lennox IMC M1-7 (version 5.02 and higher) or M1-8 over a LonWorks® network. Further information on the Lennox IMC module (including wiring connections) can be found via Lennox, document ID 0627-L5 (06/2008).

After logging into the AK-SC255, navigate to the configuration / HVAC menu and add the required amount of HVAC units, selecting 'Generic' as the type. Enter the setup screen and against the unit type, select Lennox-110x.

Create the required number of HVAC units and select Generic as type

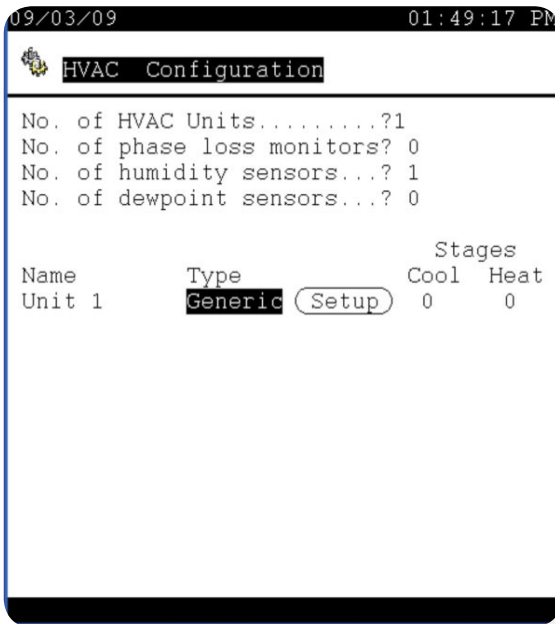

Select Lennox from drop down list



Next, enter a valid and unique network address (1-99). If generic refrigeration case controllers are also configured ensure no two same addresses are used. In the example below address 17 has been used. Press the 'Locate' button on the AK-SC255, which will result in a message dialog box (shown below). The service pin on the Lennox device now needs to be depressed in order for the AK-SC255 to detect its presence on the network.

Add unique address and press the Locate button

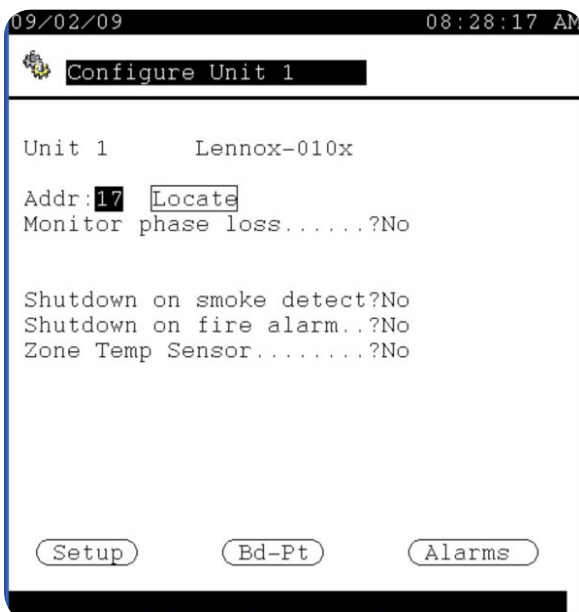

The AK-SC255 will await a response from the Lennox

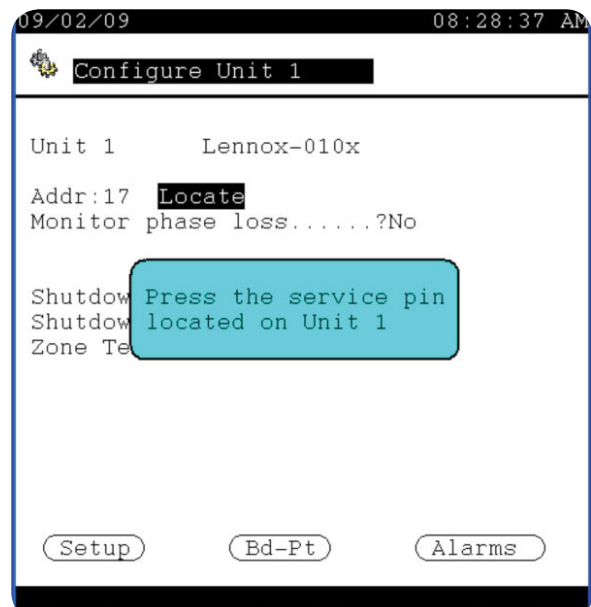

It is only necessary to perform the service pin function on the initial controller configuration or if the address of the device needs to be changed. Once the service pin location is complete, all future network rescans will automatically detect the Lennox controller(s). Once a valid service pin is detected, the AK-SC255 will display a operation successful dialog box (shown below).

After network location the following configuration questions can be found

**Monitor Phase loss** - allows the user to select a phase loss sensor which was allocated in the Main HVAC configuration screen (see screen below). This must be selected if the phase loss is to be used to create a shutdown.

**Shutdown on phase loss, smoke and or fire** - may be configured to shut down the Lennox under any of these conditions. Board & point allocations will be created for fire and smoke.

**Zone Temp** - Sensor will create a board & point allocation for a sensor.

To configure the board and points created from the above settings, press the Bd-Pt button. To configure the Lennox controller press the Setup button.

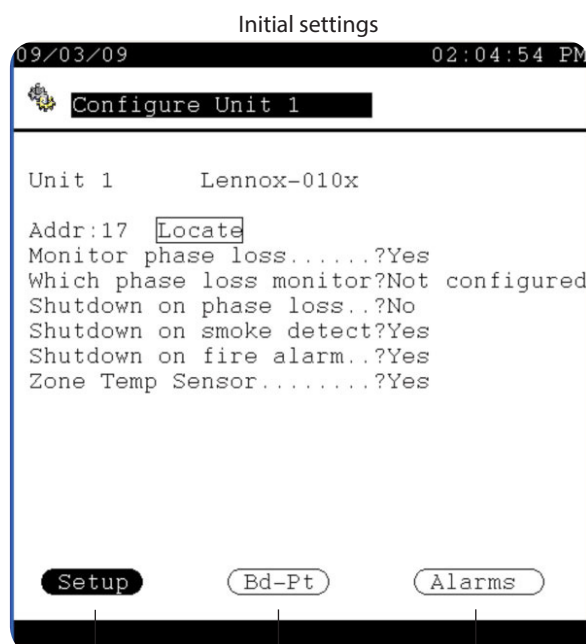
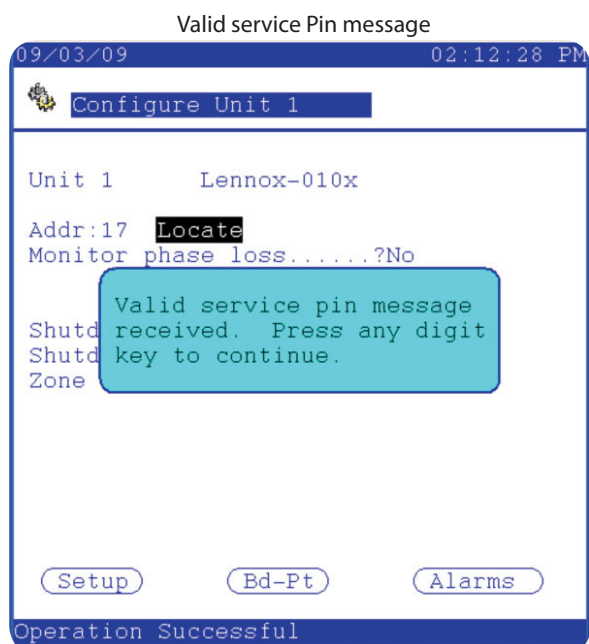

Main Lennox configuration page

Configure any Board & Points as per answered controlled questions

Alarms generated from the AK-SC255 as opposed to alarms that come from the Lennox controller

Follow the settings seen in the main unit configuration screen, note that when setting Economizer to "Yes" this will allow access to the economizer settings (on a second page - Pg Dn). Consult the Lennox user guide for full parameter description. Additional information for this settings page include;

**Occ Mode** - Allows automatic or manual control of the occupancy. In Automatic mode the AK-SC255 will use the configured schedule for the device to determine the occupancy. A central Night Setback schedule can be configured to define the required occupancy times. To configure a schedule, from the main menu navigate to the configuration page and then enter schedules (Main menu/Configuration/Schedules). Add a schedule and enter the schedule management page. Set the schedule usage to 'Night Setback' and define a suitable time frame, remembering to enable the schedule. Using the 'Controllers' button at the bottom of the screen, select the Lennox controllers (this links the schedule to the HVAC unit(s)).

**Send Temp** - Will cause the AK255 to periodically send the temperature value of the zone temp sensor in the AK255 bd-pt screen to be sent to the Lennox.

**CO2 Info, Ex Fan Info, Sec Ht Info, Dehum Info and VAV** - Info will hide the associated fields on the configuration and status screens if "No" is selected.

Selecting "Yes" for Economizer will allow the AK255 to control the economizer use in the Lennox. The AK-SC255 will periodically send a command to the Lennox indicating whether the economizer is allowed to be utilized.

The second configuration page contains settings for the Economizer control. Econ Mode allows Man On, Man Off, Rem Auto and Loc Auto to be selected. The AK-SC255 determines the economizer availability in the Rem Auto Mode based upon the Temp and/or dewpoint. The Loc Auto relinquishes control to the Lennox.

Main Lennox controller settings page

(Answer 'yes' to Economizer and a second page will be available)

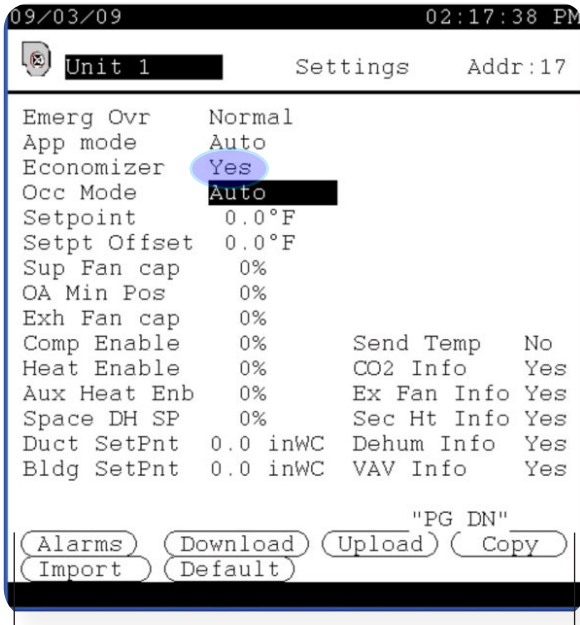

Economizer settings

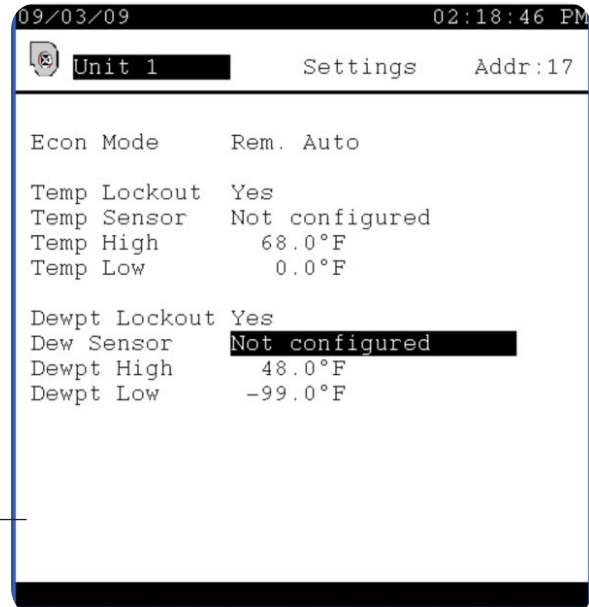

Generic controller function buttons (see Generic controller section for more details). The Alarms button will show the alarms page for this device

Example screen of the Board & Points created after selecting Phase loss, smoke & fire inputs



Example screen of the Alarms page for the Lennox controller. Alarms are generated by the AK-SC255

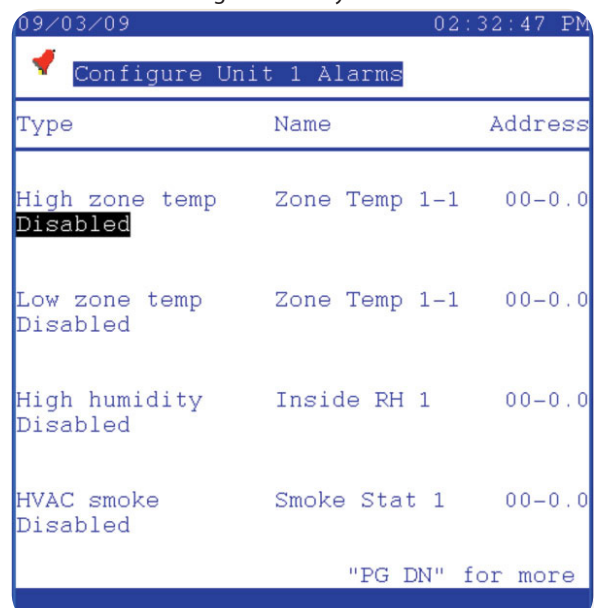

With the main configuration complete, the HVAC overview page will display the current status and temperature. By clicking on the HVAC unit line a controller detail page will be shown. The device detail page will present real time data and parameters from the Lennox HVAC controller.

**Occ Mode** - Is a setting and may be changed on this screen.

**Econ Mode**- Is a setting and may be changed on this screen.

All parameters other than those listed above are defined by the Lennox User Guide.

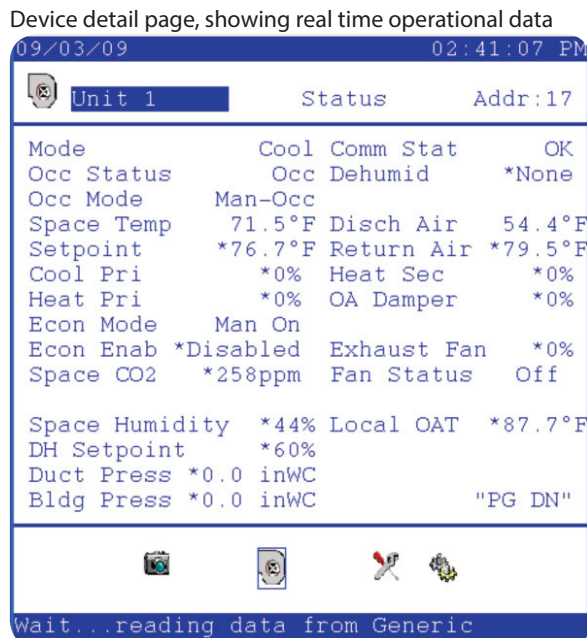

The second status screen (Page Down) contains information about alarms in the Lennox device. The 'Current alarm' field displays the alarm code which is existing in the controller, with the 'Previous Alarms' recording the previous 10 alarms from the Lennox controller.

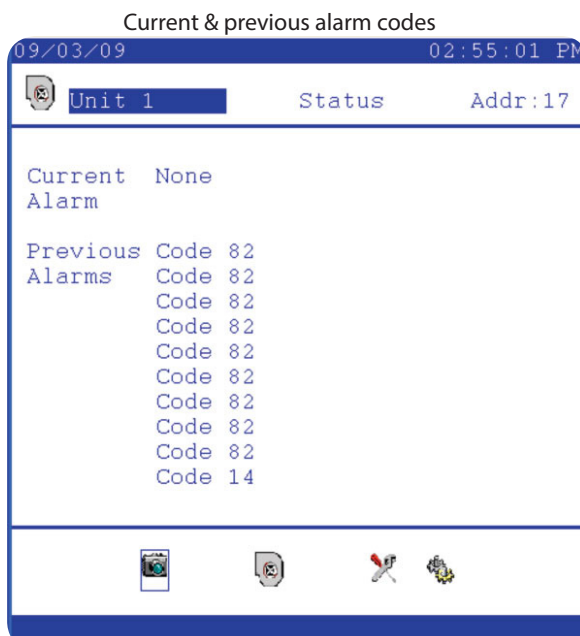

## Carrier-UPC (Modbus) HVAC Interface

### System Hardware Connections

The diagrams below show the system connections of a Carrier RTU, an UPC and a AK-SC255. The UPC (Unitary Protocol Converter) is a protocol converter which can convert between two protocols, for example Modbus to BACnet (the host protocol of Carrier RTU). **Please note a license is needed for the operation of Carrier-UPC in AK-SC255.**

#### Connection principle of a Testing System

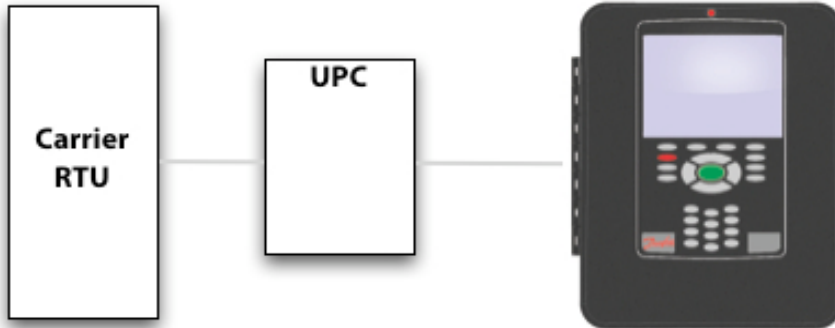

The actual connection between UPC and the AK-SC255 is shown below. Connect the UPC to the RS485 Modbus port as shown.

#### Actual connections from UPC to AK-SC255

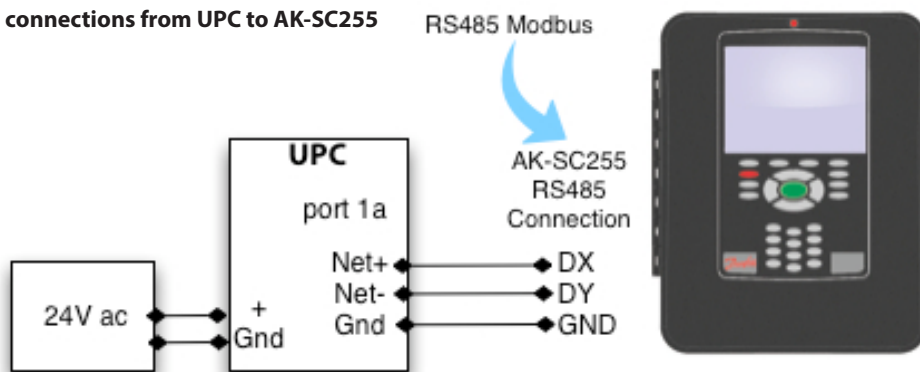

The connection of a Carrier RTU (MBB), an UPC, a Scrolling Marquee Display Unit, a 33ZCSENOAT (outdoor temperature sensor) and a HH51BX005 (space temperature sensor with setpoint adjustment T-56) as shown below.

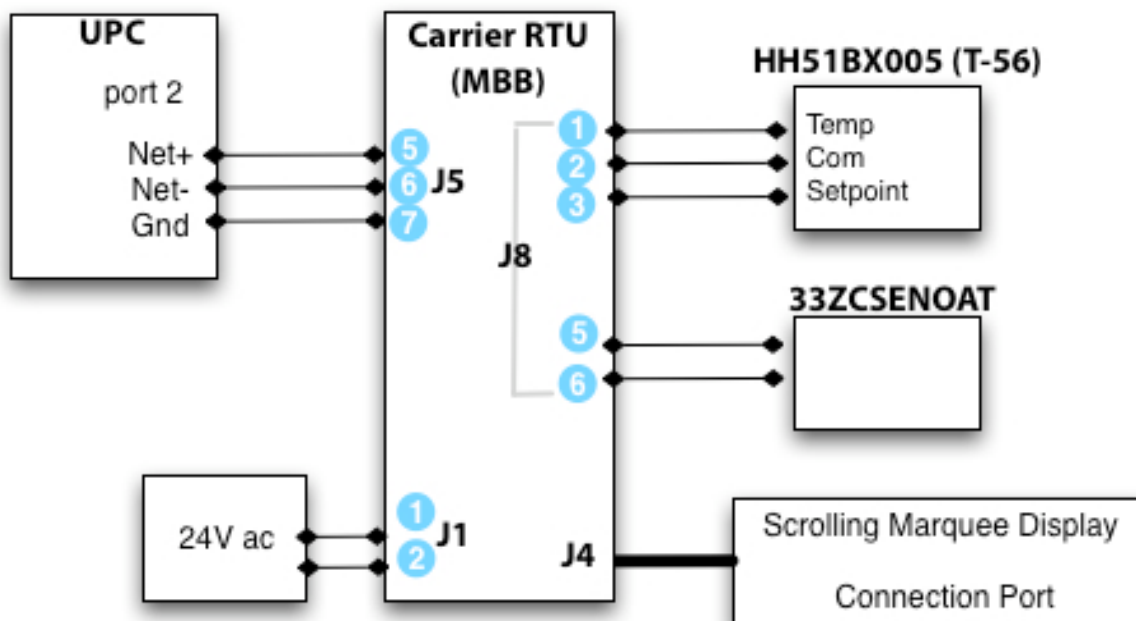

#### Actual connections of Carrier RTU



### Configuration of UPC

Configuring the UPC for Modbus protocol to **Port 1a** as follows:

- Using the rotary switches, set the UPC's address. Set the **Tens** (10's) switch to the tens digit of the address, and set the **Ones** (1's) switch to the ones digit.
- Set the Comm Selector **DIP Switches 1-8** for baud rate, port number, wiring and protocol:

- Set Comm Selector DIP Switches 1 and 2 for the communication speed:

Baud Rate	DIP SW1	DIP SW2
9600	Off	Off
19200	Off	On
38400	On	Off
76800	On	On

**Set to 38400 baud rate for Carrier-UPC!**

- Set Comm Selector DIP Switch 3 to **OFF** for BMS Port 1a.
- Set Comm Selector DIP Switch 4 to **ON** for Port 1a - EIA 485.
- Set Comm Selector DIP Switch 5-8 for **Modbus protocol**.

### Configuration of the Carrier RTU System

Refer to the document of Carrier's Rooftop Units with ComfortLink controls for the details of configuration. Based on information Danfoss have received from Carrier, apply the following configurations on the Scrolling Marquee display unit:

- Configuration->Unit->U.CTL = 3 ----- Space Sensor
- Configuration->Unit->RH.S = YES ----- Space Humidity
- Configuration->Unit->OC.FN = YES ----- Fan Control When Occupied is ON
- Configuration->Unit->SAT.H = ENABLED ---- Supply Air Temperature
- Configuration->AIR.Q->II.CF = 0 ----- Indoor Air Quality Sensor
- Configuration->Unit->RM.SW = 1 ----- Remote Occupancy
- Configuration->CCN->BAUD = 3 ----- CCN Baud Rate (Default to 3)**

### Carrier-UPC Configuration on the AK-SC255

The following configuration steps should be taken when setting up the Carrier-UPC system.

**(1)** Go to "Configuration -> HVAC", input the number of HVAC units want to be configured in the system and select "Generic" from the drop list for the HVAC unit. Then click "Setup" button to continue the configuration. Refer to the left screenshot below.

**(2)** Set the HVAC unit's address and load the edf file (Carrier-010x) from the drop list, refer to the right screenshot below.

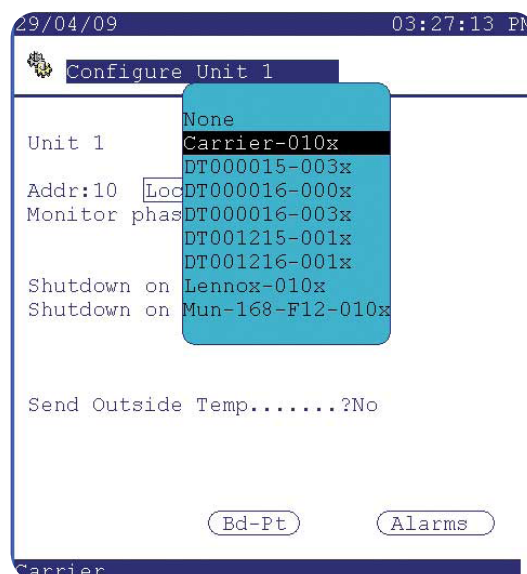
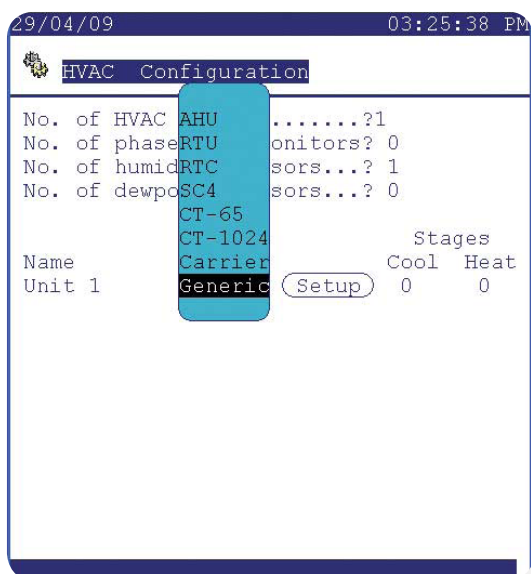

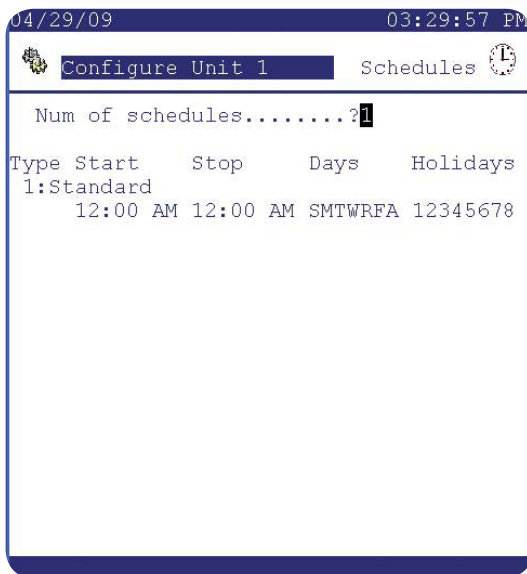
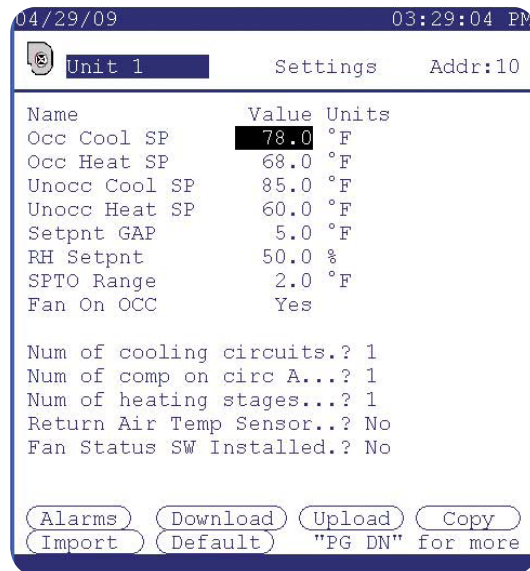
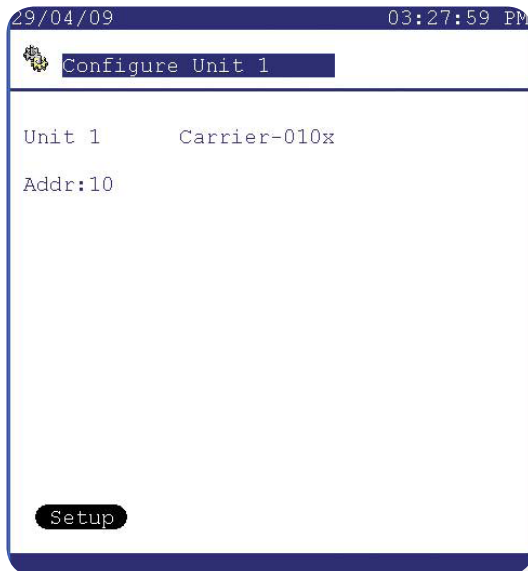

(3). There are totally thirteen (13) parameters need to be set up. The following control questions will be asked;

**Num of cooling circuits.? (1 to 3)**

This question is related to the RTU unit is picked. For 48/50PG single package small rooftop serials, sizes 03-16 units are single-circuit units (Circuit A), size 08-14 units are dual-circuit units (Circuit A and B) and size 16 units are tri-circuit units (Circuit A, B and C).

**Num of comp on circ A...? (1 to 2)**

The number of compressors on circuit A is 1 or 2 depending on the unit is picked. The number of the compressors on circuit B and C is always 1.

**Num of heating stages...? (0 to 2)**

The number of heating stages: 0: 50 series with no electric heat.

1: 48 series 1-phase, 50 series < 15 KW.

2: 48 series 3-phase, 50 series >= 15 KW.

**Return Air Temp Sensor..? (List box: No, Yes)**

This configuration identifies if a return air temperature sensor is installed on the space temperature offset input. A YES value enables the return air temperature (Return Temp) display on the status screen #1.

**Fan Status SW Installed.? (List box: No, Yes)**

This configuration identifies if a fan status SW (sensor) is installed. A YES value enables the fan status (Fan Stat) display on the status screen #1.

(4). Schedules can be found on the next page by pressing 'Page Down'. A schedule is used to set a flag to tell the carrier system if the system is in occupied or unoccupied.

(5). There are six (6) configuration options from the setting page, they are:

- Download:** Download settings from AK-SC255 database to the selected Carrier unit.
- Upload:** Upload settings from the selected Carrier unit to AK255 database.
- Copy:** Copy settings into other selected controllers in the AK255 database. You still need to click on download to send the settings to those controllers.
- Default:** Load default values from AK255 database.
- Alarms:** Generic alarms configuration. Here the AK255 can be configured to act on any of the controller's alarm parameters.
- Import:** Import controller's parameters into the AK255 database as miscellaneous points, and then alarms can be configured from these miscellaneous points you have set up (i.e. Misc Sensors and Misc On/off inputs). Starting from Main Menu -> Go to Configuration -> Alarms -> Miscellaneous. For more details on Misc Points, refer to the AK25C-255 User Manual.

## Configuration of the Modbus Communication Channel

After the HVAC unit has been configured as described in the previous section, the AK-SC255 Modbus communication channel requires configuration. From the main menu, select "Communication", then select "I/O Network", I/O network status screen will be shown, move the cursor to "Rescan Channels" and press ENTER. Select "Channel MODBUS-RS485" check box and a warning box will appear in the centre of the screen cautioning that:

1. EKC Modbus devices may NOT be connected with other Modbus devices on the same SC255.
2. If you select I/O channel to Modbus, you MUST set the Host network protocol to Ethernet.

After press key 1 to confirm, the rescan channel selection menu will appear again with channel MODBUS-RS485 box checked. Choose "Rescan Network" to start the rescan process. The rescan process will scan the Modbus communication network with the different configuration setup. This rescan process will take less than 2 minutes to finish. Currently, there are three (3) different setups which need to be scanned.

- 1). Configuration 0: 38400 baud rate, even parity for EKA/EKC.
- 2). Configuration 1: 38400 baud rate, none parity for Siemens and Carrier UPC.
- 3). Configuration 2: 9600 baud rate, none parity for Carlo Gavazzi Meters.

A text string message will appear on the bottom of the screen to indicate which configuration is being scanned. After the rescan has finished, go back to the "I/O Network" menu and choose "List Nodes", if the communication channel works fine, the each HVAC unit connected to this AK2-SC 255 should appear as "online".

At this point, the HVAC units are configured correctly.

Main Menu->Communications->I/O Network->Rescan Channels page

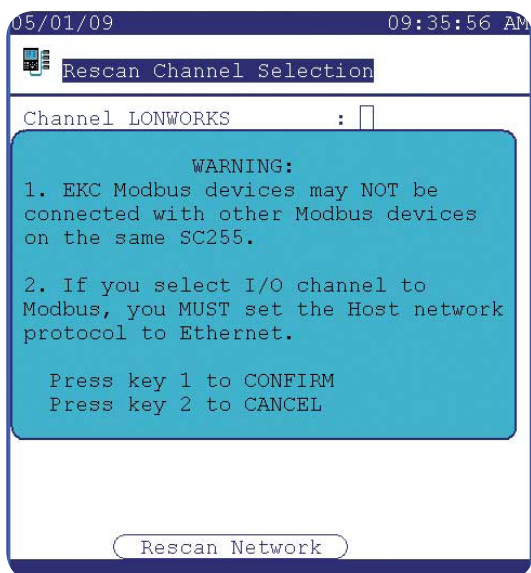

Rescan Channels page showing the Modbus and Lonworks ports selected. Press the Rescan Network button to scan network

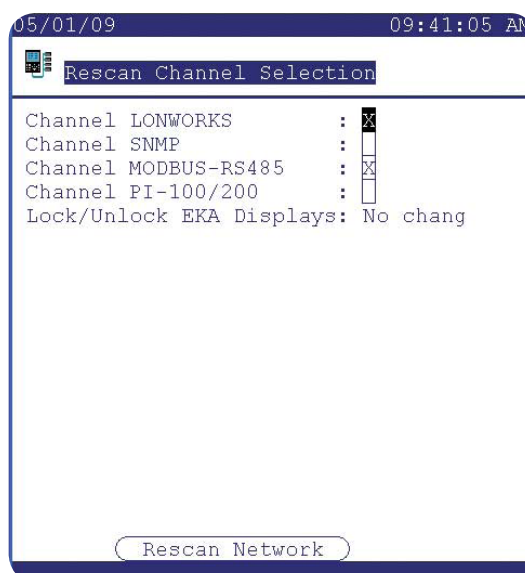

## Carrier-UPC Status on AK-SC255

To view and monitor the HVAC status, start from the Main Menu -> HVAC, the Carrier RTU status is shown below. The displayed status is HVAC Mode, and the temperature is space temperature (SPT). Click on it to view the details of the first status page. Press page down to go from status page 1 to status page 2, and then to status page 3, as the screen shots below indicate.

Some detail information on the status page 1:

SYS Mode: Disabled, Enabled and Test.  
 HVAC Mode: Disabled, Fan Only, Cool and Heat.  
 Unit Type: Auto, Thermostat and SP Sensor.  
 CCN Comm: Yes/No.  
 Occupied: Yes/No.  
 Fan On OCC: Yes/No.  
 Fan Stat: Off/On.  
 IAQ Enable: Yes/No.

If Yes, items (IAQ SW and IAQ Level) will be displayed.  
 If No, items (IAQ SW and IAQ Level) will not be displayed.

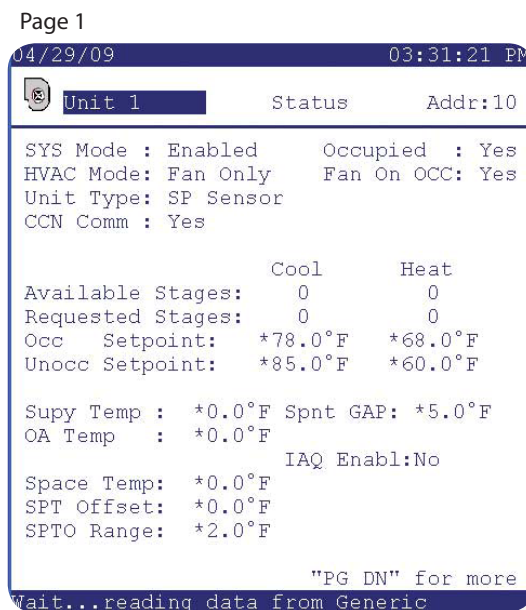
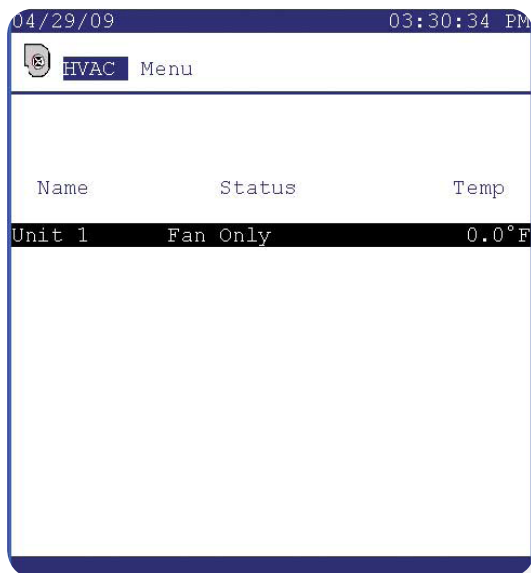

On the status page 2:

How many numbers of compressors, suctions, condensers and heating stages showing up on the status screen are depending on the unit picked and configured.

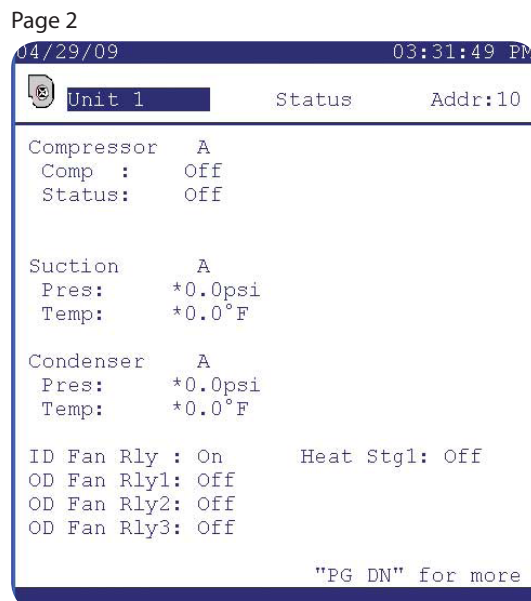

On the status page 3:

Economizer: Yes/No.

If Yes, items (Actual POS, CMD POS and Min POS) will be displayed.

If No, items (Actual POS, CMD POS and Min POS) will not be displayed.

Humidimizer: Yes/No.

If Yes, items (RH Ddband, setpoint, Space RH, RHT2 Val A and B) will be displayed.

If No, items (RH Deadband, setpoint, Space RH, RHT2 Val A and B) will not be displayed.

PW Exhaust: Yes/No.

If Yes, items (PE Stg1 POS, Stg2 POS, PW Exhaust 1 and 2) will be displayed.

If No, items (PE Stg1 POS, Stg2 POS, PW Exhaust 1 and 2) will not be displayed.

Alarms:

Filter Stat: CLN/DRT.

Fire Shtdwn: Off/On.

There are three Page links from the status page 3 and they are History page, Status page 1 and Configuration page.

### Technical Notes:

(1). Polling Parameters:

- 1). HVAC Mode.
- 2). Space Temperature.
- 3). Filter Status.
- 4). Fire Shutdown.

(2). Auto Configured History Parameter:

- 1). HVAC Mode.
- 2). Space Temperature.
- 3). Supply Temperature.
- 4). Fan Status.
- 5). Occupied.

(3). **A license is needed for the operation of Carrier-UPC in AK-SC255.**

Page 3

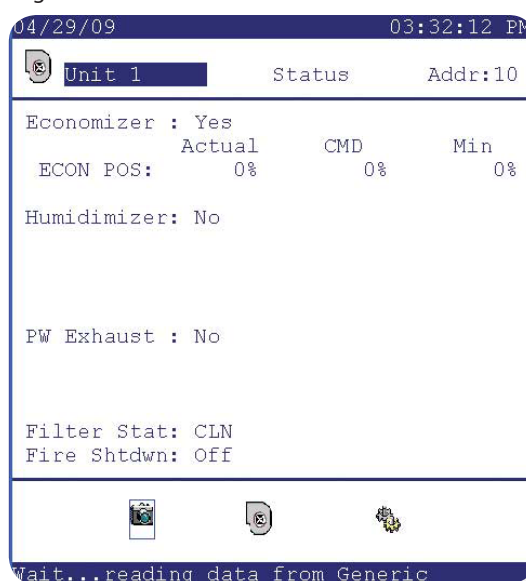

## Com-Trol local bus interface

The Schneider Electric© group has formally granted Danfoss Inc the intellectual rights to it's Com-Trol control products. Danfoss Inc is the only official controls supplier which is recognized as the recommended replacement solution for your Com-Trol installation. This section describes the required steps in the AK-SC255 in order to facilitate Com-Trol local bus support. **Please consult the available Com-Trol to Danfoss Installation guide for more details (USCO.El.RF0.A1.22.CT / 521U0185 )**

The following important points define the intended application scope for a Com-Trol (local bus) retro-fit installation. Please read these fundamental requirements before continuing.

- One Com-Trol 4K/4K2e should be replaced with one Danfoss AK-SC255 unit
- The Danfoss AK-SC255 RS-485 (Modbus) port is used for communication to the Com-Trol I/O boards. **Host communication to other AK -SC255 and/or AK-SC255 Loggers must be done via the Ethernet port.**
- Only one local bus loop can be connected to the AK-SC255 - No star wiring configurations allowed
- Valid local bus termination and wiring rules must be applied and maintained
- Existing system capacity for number of Com-Trol I/O boards (defined by Com-Trol documentation) must be maintained
- AK-SC255 software version R2.151 and above must be used in order to provide Com-Trol support
- The AK-SC255 being used in the application must have a valid Com-Trol license installed. If a license is required contact Danfoss Customer service on 410-931-8714 with the AK-SC255 MAC address



Com-Trol I/O boards with dates prior to 1998 will cause compatibility issues. Consider replacing with Danfoss I/O

There are 10 types of I/O boards of various configurations including 3 combination boards. They are:

**RO-8 (Relay output board), DI-8 (Digital input board), AI/DI-16 (Combination analog/digital input board)**

**AO-4 (Analog output board), RTU board, CIO board, Pulse/Solid State Relay board, ESB-8 – Electronic EPR Stepper Valve Control Board, Single Board, Pulse Meter Adapter**

There are 33 sensor types that can be interfaced in the Com-trol local bus. They are primarily temperature and pressure sensors, but they can also be refrigerant, light and energy sensors.

### Enable Com-trol Local Bus

To begin configuration of Com-trol local bus, select "Store Info" from the main menu and press ENTER. Select "Preferences" and press ENTER, select Legacy I/O type...? to "**COMTL**" from the Menu and press ENTER. This selection will enable or disable the Com-trol local bus configuration in the AK-SC255.

The Com-Trol selection can not be disabled if;

- 1). One or more Com-trol local bus point(s) has/have been configured.
- 2). COMTL has been selected in the Rescan Channel Selection screen.

Preferences screen  
(set Legacy I/O to COMTROL)

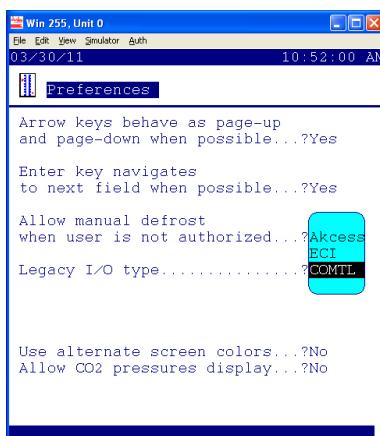

## Rescanning of Com-trol Local Bus Communication Channel

The AK-SC255 unit communicates with Com-trol I/O boards using the Modbus RS-485 port over an RS-485 serial bus (3 wire cable) at 19,200 baud rate. The host network of the AK-SC255 unit must be set to Ethernet.

The cable is connected from I/O board to I/O board using Daisy chain topology, and no branches are allowed on the cable. If the cable length exceeds 1200m a repeater must be inserted. Ensure correct termination at both ends of the network run (AK-SC255 end and last board ). The termination should be made with a 120-ohm resistor.

### Rescanning of Control Local Bus

A rescan of the Com-trol local bus communication channel is required before or after Com-trol I/O boards are configured.

From the main menu, select "Communication", then select "I/O Network", I/O network status screen will then be shown, move the cursor to "Rescan Channels" and press ENTER. Select "Channel MODBUS-RS485" check box and a warning box will appear. After pressing key 1 to confirm, the rescan channel selection menu will appear with channel MODBUS-RS485 box checked. Select "COMTL" from the drop list and press ENTER. A warning box will appear, cautioning that AK-SC255 will use RS-485 port to communicate with Com-trol IO boards. After pressing key 1 to confirm, the rescan channel selection menu will appear with channel MODBUS-RS485 box checked and "COMTL" selected.

Choose "Rescan Network" to start the rescan process. The rescan process will scan the Comtrol local bus communication network with the different configuration setup. This rescan process will take about 2 minutes to finish. After the rescan is complete, go back to the "I/O Network" menu, and select "Overview" to see comm status.

### Configuration of boards & points for Com-trol IO Boards

When configuring an IO point for the Com-trol IO boards, the function key "F4=COMTL" must be selected first on the board & points configuration screens (RO, SI, OI and VO).

An IO board & point number must be entered as:

- a). The first number: IO board address (RO, SI, OI and VO) – (2 digits) from 01 to 32.
- b). The second number: point position – (1 digit) from 1 to 8 for RO, SI and OI.  
– (1 digit) from 1 to 4 for VO.

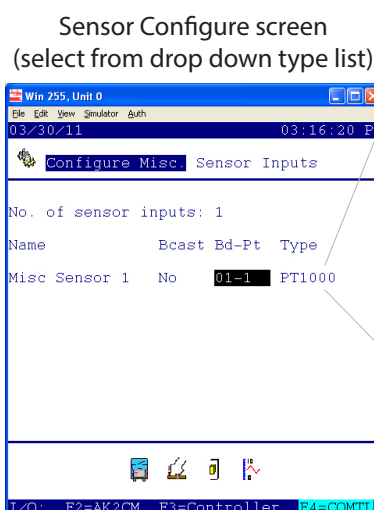
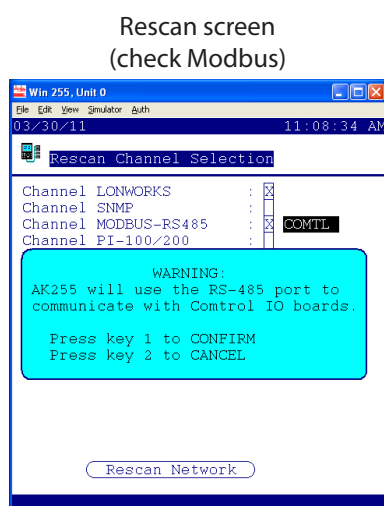

CMT RegTemp  
CMT HiTemp  
CMT Dewp F  
CMT P100  
CMT P200  
CMT P500  
CMT FtCnd1  
CMT CFreon  
CMT OilPres  
CMT HansLq  
CMT Percnt  
CMT P10X  
CMT P20X  
CMT P50X

*new Com-Trol sensor selection*

Use the F4 function key to enter valid Com-Trol I/O addresses

## Central Alarm Configuration (new in 02\_081 software)

New for version 02\_081 software, the AK-SC255 utilizes an Alarm Action Matrix that allows a high degree of flexibility for various alarm routing options. At the heart of the new alarm configuration is the alarm 'Action' page, where different routing options can be defined, along with time delays and alarm stop conditions. The following section describes the functionality, scope and implementation of the central alarm configuration and how associated controller points are assigned these alarm actions.

The central alarm action matrix allows various output options and alarm handling configuration to be centrally assigned. Once the alarm action matrix has been defined, any controller or I/O alarm point can be given an **alarm action** number. The alarm action number corresponds to the appropriate output. (as defined in the alarm routing page). Alarm output options include;

- 10 external (AK I/O) relay outputs
- Local AK-SC255 buzzer
- Local AK-SC255 front LED
- Internal alarm relay
- 3 modem dial out options
- 4 IP / e-mail addresses
- Serial printer output.

The following example should be seen as a guide to configuring your AK-SC255 alarm logic options;

In order to configure the alarm actions, Supervisor level access is required. Once logged in as Supervisor, navigate from the **Main menu**, to **Configuration** and then **Alarms**, this presents the Alarm Configuration page (shown below).

1/ Enter into the **Routing** page by selecting the Routing icon

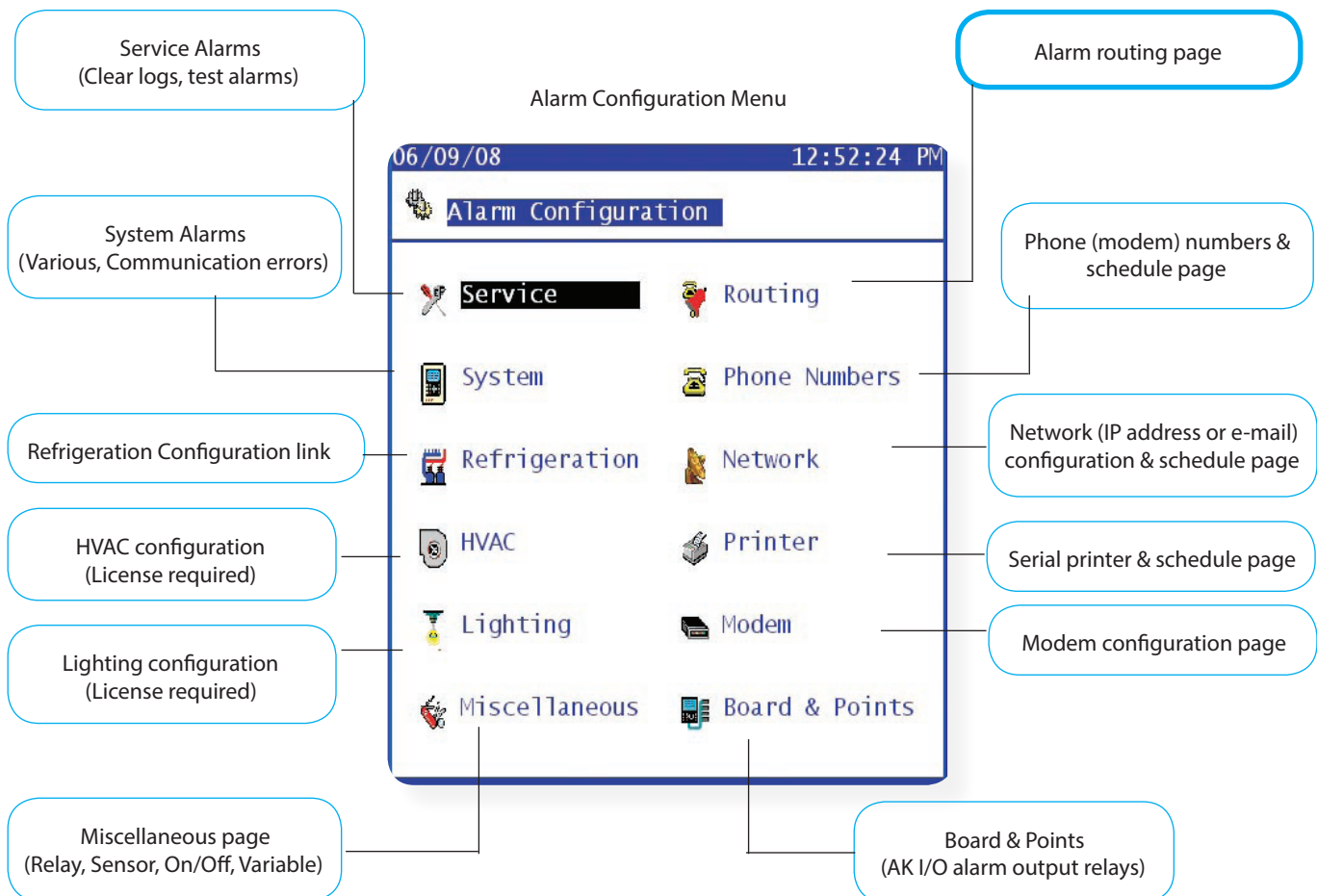



2/ When in the alarm routing page, an array of output routes (including relays (A-J), Modem, e-mail, will be presented along with the Alarm Actions (1-8) and the associated action stop conditions.

On the left hand side of the screen, the output options are displayed in column form. The first page shows 10 available relays for configuration, each relay has a factory name of 'Relay A' to J. The alarm actions are then shown from 1-8, followed by the time delay before any output will activate (this delay is in addition to any alarm delay set in the controller or monitoring points). A duration column then allows the user to define how long the output route should be energized for (only available under Time or Time/Repeat conditions). The Stop column represents the different alarm stop conditions that will cause the alarm output to stop. The stop conditions range from Time, Acknowledge, Clear, Time & Repeat, Acknowledge & Repeat.

Principle of operation

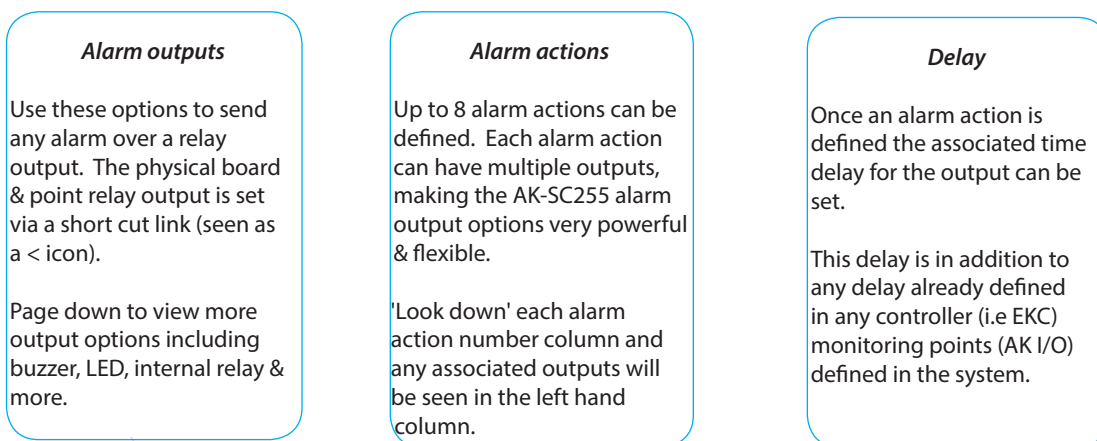

	1	2	3	4	5	6	7	8	Delay	Duration	Stop
← Relay A	---	---	---	---	---	---	---	---	---	---	---
Relay B	---	---	---	---	---	---	---	---	---	---	---
Relay C	---	---	---	---	---	---	---	---	---	---	---
Relay D	---	---	---	---	---	---	---	---	---	---	---
Relay E	---	---	---	---	---	---	---	---	---	---	---
Relay F	---	---	---	---	---	---	---	---	---	---	---
Relay G	---	---	---	---	---	---	---	---	---	---	---
Relay H	---	---	---	---	---	---	---	---	---	---	---
Relay I	---	---	---	---	---	---	---	---	---	---	---
Relay J	---	---	---	---	---	---	---	---	---	---	---

**Duration**

A duration time is available when either Time or Time/Repeat are selected as stop conditions. The duration setting defines the length of time the alarm output will be active for (irrespective if the alarm is still active or acknowledged or not)

Available in second or minute selections

**Stop**

The stop condition defines when the alarm output will stop or return to configured position.

The following definitions apply;

**Time** = Stop on time (set under duration)  
**Ack** = Stop on alarm being acknowledged  
**Clear** = Stop when alarm clears  
**Time/Rep** = Stop after time delay but repeat if alarm is still active  
**Ack/Rep** = Stop after alarm is acknowledged if alarm still active after acknowledge repeat alarm action (repeat delay after stop is programmable)

3/ The alarm action screen, shown below identifies some of the possibilities of the alarm action matrix. In this example, 5 actions have been defined with associated relay outputs, time delay, duration and stop conditions. An explanation of the alarm actions and stop conditions are described in the following section;

### Alarm action 1

Looking down the column for alarm action 1 Relay A has been selected (x). Selecting x indicates that this action will occur at any time and is NOT subject to any day/night time restrictions. As Relay A is selected for this action, look at the delay, duration and stop condition. A time delay of 30 seconds, duration of 99 minutes and a stop condition of Time have been set. **When the value of 99 is used at any time in the alarm action setup this effectively informs the AK-SC255 to ignore this setting.**

The result of this configuration can be summarized as;

'Action 1 - when alarm occurs and after a pre delay of 30 seconds, Relay A will trigger at any time of the day/night. As the duration is set for 99m (output stays active until stop condition reached by alarm clear or user acknowledge) the time stop condition will be based on the delay time value, i.e. 30 seconds.'

### Alarm action 2

Alarm action 2 uses relay A and relay B. In this instance however, relay A will only activate during store open hours (described as Day time). To define the open (Day) and Close (Night) times, navigate to the Operating Hours screen - seen via Configuration / Store Info / Operating Hours. As relay B is marked as x this relay will energize at any time of the day. Relay A will stop under the same conditions as previously described under alarm action 1.

The result of this configuration can be summarized as;

'Action 2 - when alarm occurs and after a pre delay of 30 seconds, Relay A will trigger at ONLY if the AK-SC255 sees the time as DAY- else no action is taken on relay A. After 30 seconds delay, relay A will reset. Relay B will also energize after a delay of 1 minute, and will only reset when the alarm is acknowledged.'

### Alarm action 3

Alarm action 3 uses relay A. As a 'N' (Night) has been defined this only activates relay 'A' during Night time conditions, as per described in the store open hours. The delay, duration and stop conditions are as previously described.

The remaining actions in this example use a mixture of 'always on' (x) or 'D' (Day) options, with the following stop conditions;

- Time** = Stop on time (set under duration)
- Ack** = Stop on alarm being acknowledged
- Clear** = Stop when alarm (either acknowledged or unacknowledged) clears
- Time/Rep** = Stop after time delay but repeat if alarm is still active
- Ack/Rep** = Stop after alarm is acknowledged if alarm still active after acknowledge repeat alarm action (repeat delay after stop is programmable)

The repeat delay after stop line appears when either the Time/Repeat or Ack/Repeat stop conditions are set, use this line to define the required time delay.

Clicking on the < icon allows the Name, 255 address, Board & Point and relay status to be defined.

To display the custom name in the alarm action screen - toggle the **Items** button (seen in the Alarm Actions page).

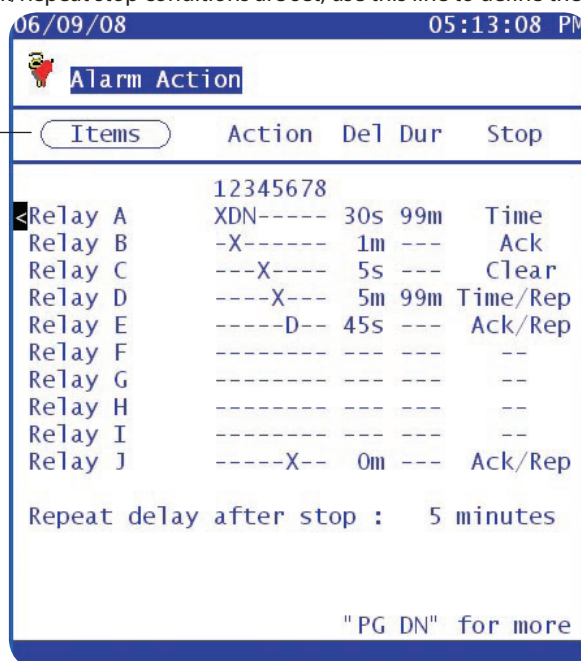
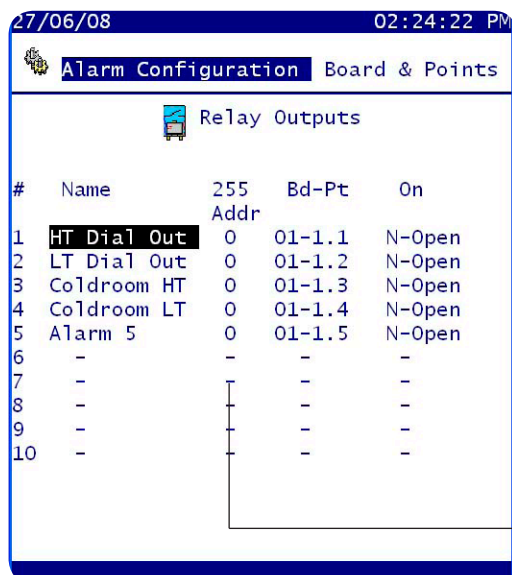

If using multiple AK-SC255 units (and unit 0 is the alarm output device) the ability to route alarms from 'slave' units to the master unit is possible. In the slave units make sure the 255 address number is set to 0 (Master AK-SC255)

4/ After the first page of the Alarm Action screen has been defined, press the Page Down line and the remaining alarm action page(s) are displayed. This screen allows the AK-SC255 LED, Buzzer, internal relay, modem, IP address, and Printer routes to be configured. Using the same principles as used in the previous Alarm Action screen.

In addition to the 10 relays (A-J) an internal AK-SC255 relay can be used for alarm output.

If an IP address or e-mail is required for alarm output, select the < icon and the network connection page will be displayed. From this page select the type of alarm (e-mail or remote IP address). To ensure correct output make sure that schedule 1 has been selected and that a valid From - To time / date has been defined, as shown below. **Failure to set schedule 1 will stop all e-mail / IP remote address being sent out. This is also true for Phone number & printer outputs**

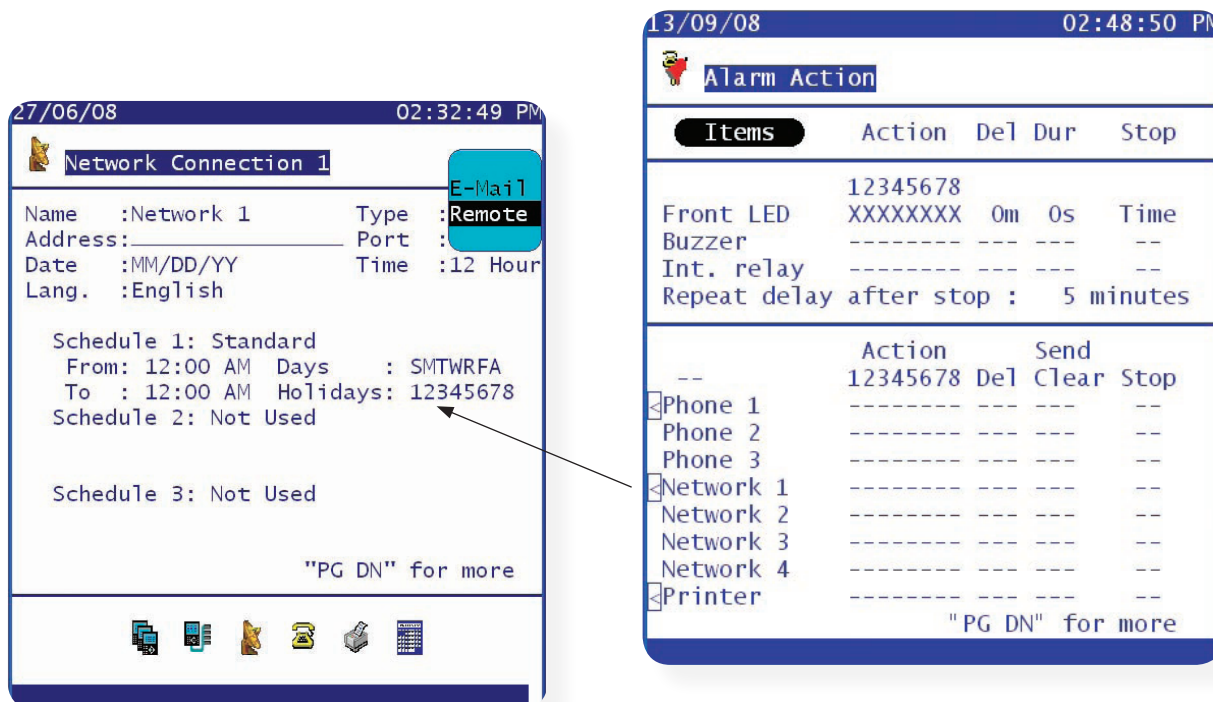

The final screen in the Alarm routing setup provides the option to identify which AK-SC255 will be used to output the alarms. In applications where multiple AK-SC255 units are interconnected, use this page to define which AK-SC255 issues out the alarm outputs.

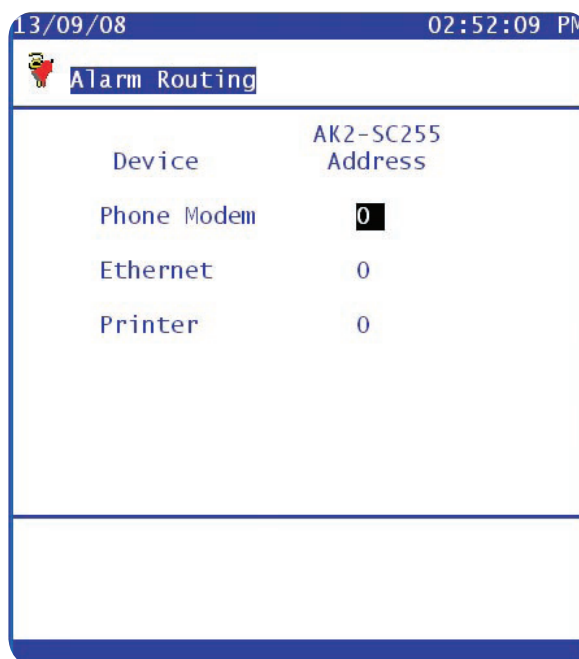

5/ Once all alarm action configuration has been completed, use any of the programmed actions [numbers] in subsequent controller, sensor, monitor or miscellaneous alarm configurations.

6/ Example of alarm action defined in circuit configuration -

The typical example below (Evaporator circuit) shows that the Low & High temperature limits have been set for alarm actions 1 & 2 respectively. The level of alarm is then selected via a drop down list - in this example Normal & Severe have been selected.

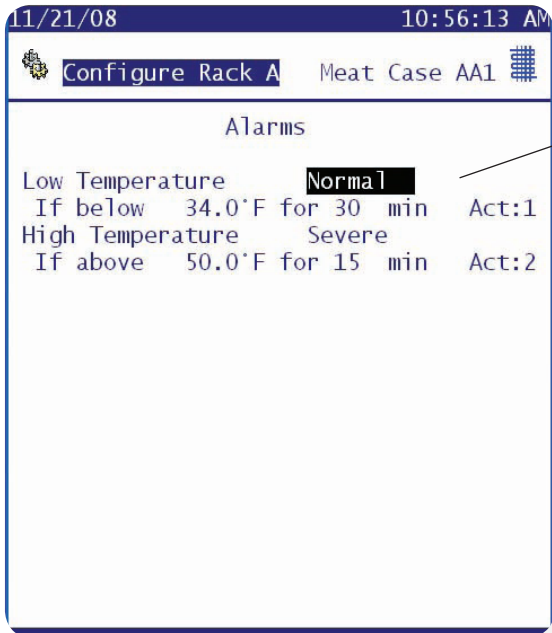

Alarm action number set here will correspond to central alarm action page. The output associated for the alarm action will be triggered

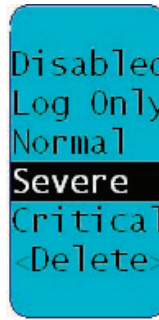

**Disabled** - No alarm will be sent

**Log Only** - AK-SC255 will log alarm only - no alarm output

**Normal** - Alarm sent ONCE

**Severe** - Alarm sent & re-sent (re-trigger time set in alarm action configuration)

**Critical** - Same as Severe but with separate & independent re-trigger time

**Alarm Actions - Service**

Once the main alarm actions have been configured it is possible to setup system test alarms. A system test alarm from the AK-SC255 can be used to confirm correct alarm action setup and output and also prove active alarm connection to any remote alarm service. From the main menu navigate to the Alarm Service screen via *Main Menu/Configuration/Alarms/Service*.

The upper part of the screen holds 4 buttons which reflect the described actions. To setup a system test alarm, first select a system test alarm action. Select from Disabled, Log Only & Enabled. If Log only is selected, the alarm only logs an entry in the alarm log and **will not output** any physical alarm relay etc. Next, select the appropriate alarm action that is required to be tested, in the example below action 1 and it's associated outputs will be tested.

Select the **Manual Test** button if an immediate alarm is required - this will be reflected in the alarm list as a 'Test Alarm'. To configure automated test alarms, set the Auto Test line to the required level - Scheduled or Requested.

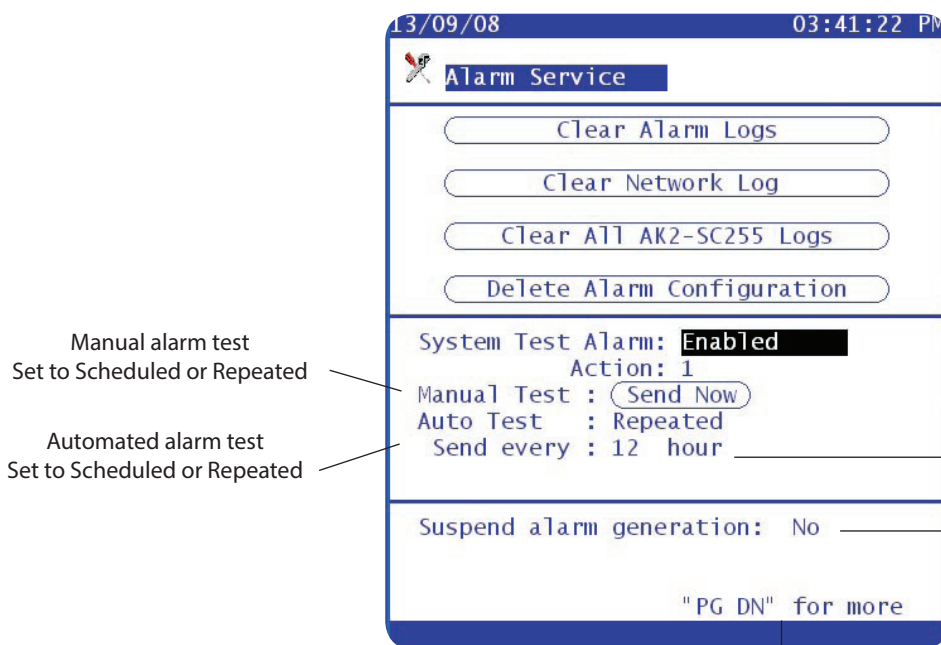

Manual alarm test  
Set to Scheduled or Repeated

Automated alarm test  
Set to Scheduled or Repeated

Select the required time level

Select 'yes' to suspend all alarm output on the AK-SC255, for the selected time period. A count down timer will be shown indicating when alarm suspension is removed & alarms will be sent

The final page in the alarm service screen allows the manual override of any connected alarm relays

## Alarm routing summary

The previous example shows how to configure the AK-SC255 alarms for IP, e-mail, modem, printer routing. In addition the red LED and siren was also described. The Alarm Routing page is the central matrix setup that allows the user to define where alarms get sent or routed to. Ensure the class 'System' is ticked as this will allow the AK-SC255 system and controller offline alarms to be generated. For 'Generic' controllers use the class 'Case' for evaporator controllers.

Ensure that an alarm schedule is set so that alarms can get transmitted, the factory default is 12:00 - 12:00 or 00:00 - 00:00, which is 24hrs - thus allowing alarms to get routed at any time.

For e-mail alarms ensure the DNS settings have been configured in the 'Configure Internet' page and that the e-mail addresses have been filled in at the 'e-mail configuration' page.

Example of an alarm via e-mail

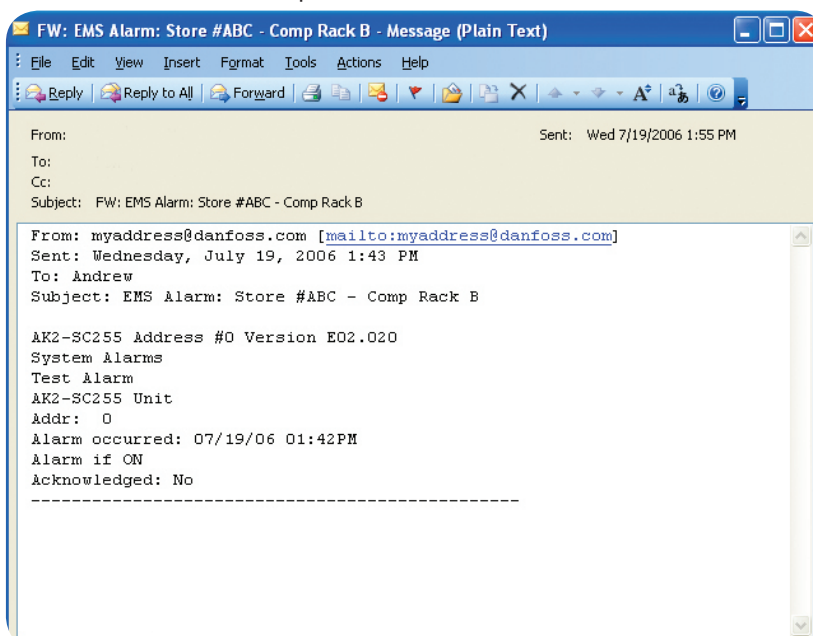

Example of 'text string' alarm

```

02/16/03                Danfoss Automatic Controls                12:37AM
A&P 27-613                Rack B
AKC 55 Address #2        Alarm Log: Danfoss                version 0.687
System Alarms
I/O Comm error                Case                Addr: 6
Alarm occurred: 02/16/03 12:37AM        Current value: Trip
Alarm if error                Acknowledged : No
-----
02/16/03                Danfoss Automatic Controls                12:37AM
A&P 27-613                Rack B
AKC 55 Address #2        Alarm Log: Danfoss                version 0.687
System Alarms
I/O Comm error                Case                Addr: 9
Alarm occurred: 02/16/03 12:37AM        Current value: Trip
Alarm if error                Acknowledged : No
-----
02/16/03                Danfoss Automatic Controls                12:37AM
A&P 27-613                Rack B
AKC 55 Address #2        Alarm Log: Danfoss                version 0.687
System Alarms
I/O Comm error                Case                Addr: 4
Alarm occurred: 02/16/03 12:37AM        Current value: Trip
Alarm if error                Acknowledged : No
    
```

## Daily User/ frequently used screens

To cater for the daily user or frequent service personnel the AK-SC255 has a simple set of screens that provide access to the key areas of system performance and information. Typically the user authorization for daily users will have been predefined by the commissioning process and thus when a daily user logs into the system a limited range of screens are available. For the daily user the AK-SC255 system will be used to highlight any alarms in the refrigeration system, check on key parameters and allow repetitive tasks to be done easily. The following screens are examples of what the daily user can expect to see when performing the day-to-day management of the refrigeration / food safety checks.

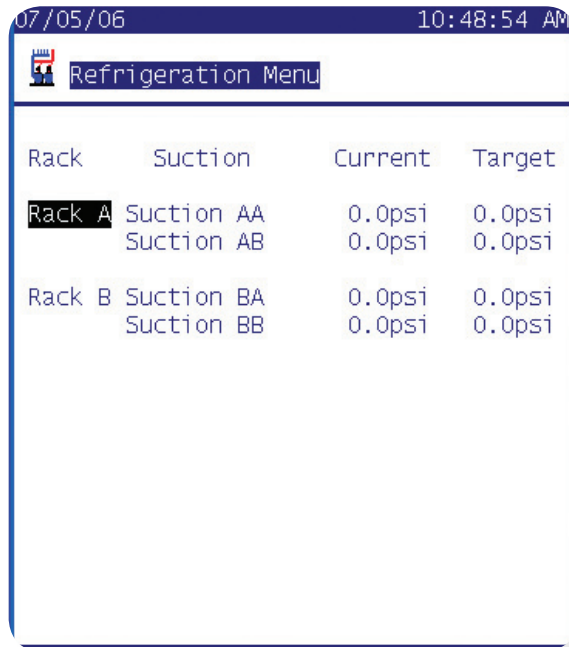

Refrigeration menu

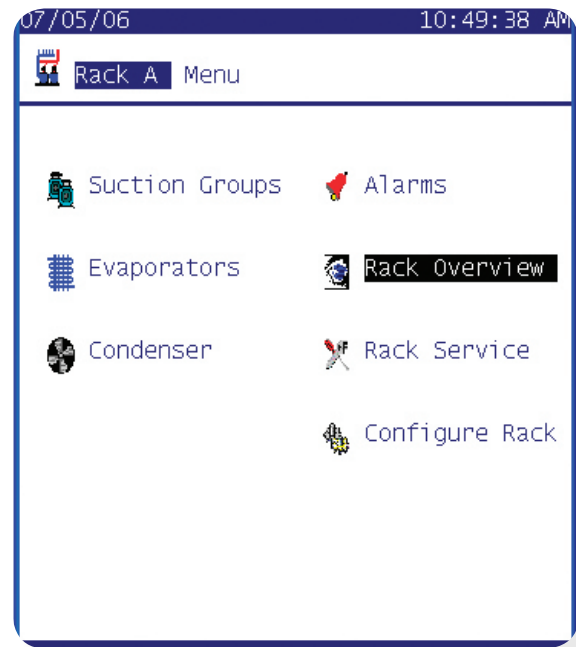

Rack Overview

One of the main screens available to the daily user is the 'Refrigeration Menu' page. This page simply highlights the current Rack pressures and references the target. This page can be used to quickly identify how well the refrigeration system is controlling against the desired set points.

By selecting a relevant Rack the 'Rack Overview' page is displayed. This is a central location from which most of the Rack and evaporator details can be found.

Select the 'Suction Groups' from the Rack Overview page and the suction status page can be seen. Use this page to view information on the operational running conditions of the refrigeration system.

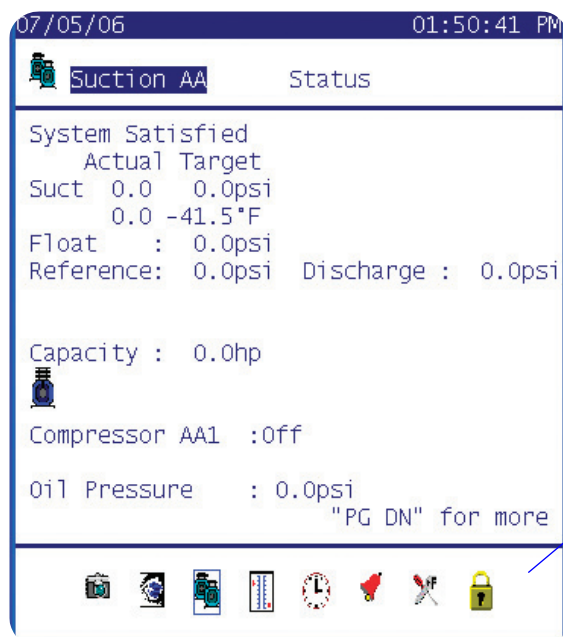

Suction Status Screen

The main body of the page provides critical system information.

Short cut icons to further system pages

From the Rack menu, select Evaporators. A list of the configured circuits will be shown along with network device address, current running and target temperatures. Select a circuit and the evap detail page will be shown, in this example the AK2 Case controller.

To expand and enter the controller details, click on the circuit evap

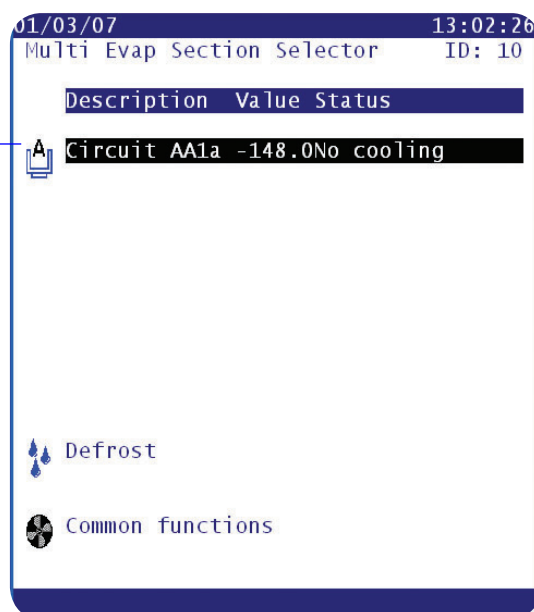
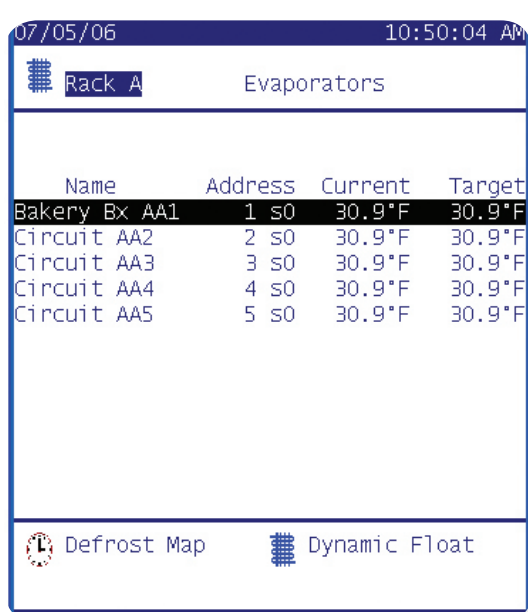

### Manual Operation

In order to assist in the operation of frequently used or key controller functions the AK-SC255 has a easy to use 'Manual Operation' function. By selecting the appropriate evaporator circuit the manual operation buttons can be seen. Select the appropriate manual operation (dependent on controller type). Be aware that some manual override operations may cause stock loss if not used correctly (i.e. Main Switch will stop refrigeration to the evaporator device). The user must have correct authorization in order to use the manual operation function.

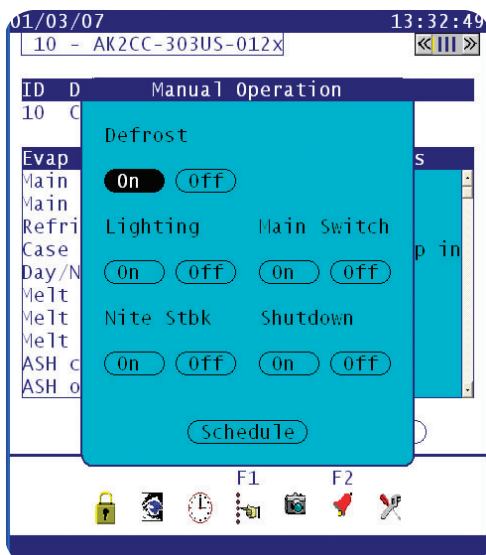

Typical Manual Operations :-

- Defrost - Triggers manual defrost
- Lighting - 'Toggles case lighting on/off
- Main Switch - Turns controller on/off
- Night Set Back
- Shutdown - Turns case into 'force close' mode



The Manual Operation dialog box reflects available options in the controller, different options may be seen per controller type. When using AK2 controllers the Service tool may be needed for further configuration.

# Appendix

65	<b>Off-Line Programming / Remote access</b>
66	<b>System Screen Navigation (screen layout &amp; local keypad)</b>
68	<b>Update AK-SC255 System files (using AKA65)</b>
68	<b>Save System Setup</b>
69	<b>Board &amp; Point Setup</b>
70	<b>AKA65 Software Support Tool</b>
76	<b>Updating AK-SC255 firmware via Codeloader Version 4.1/ USB</b>
83	<b>Industrial defrost configuration</b>
89	<b>Compressor, Condenser, Heat Reclaim, Exhaust fan control</b>
97	<b>Dehumidification / Reheat</b>
97	<b>HVAC Heating - Individual setback for heat reclaim / Aux heat</b>
97	<b>Refrigeration condensers - hot gas offsets and lockouts</b>
98	<b>Lighting Panel Square D PowerLink G3 (Modbus)</b>



## Off-Line Programming / Remote access

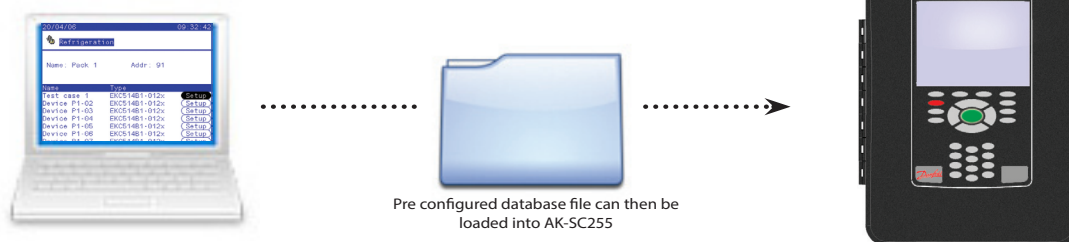

One of the major advantages of using the AKA65 remote support software tool is that the previously described steps in commissioning a site can actually be done offline.

Utilizing the AKA65 tool allows the commissioning of a AK-SC255 database to be completed and subsequently saved, later to be loaded down to the AK-SC255. This means that the vast majority of the commissioning process can be done prior to being on site.

To Commission off-line and start a new database simply start up the AKA65 remote software tool and follow the steps below;

- Click the 'Options' button check the 'Directories' tab and ensure the AKA 65 is pointing to the correct WIN55 program

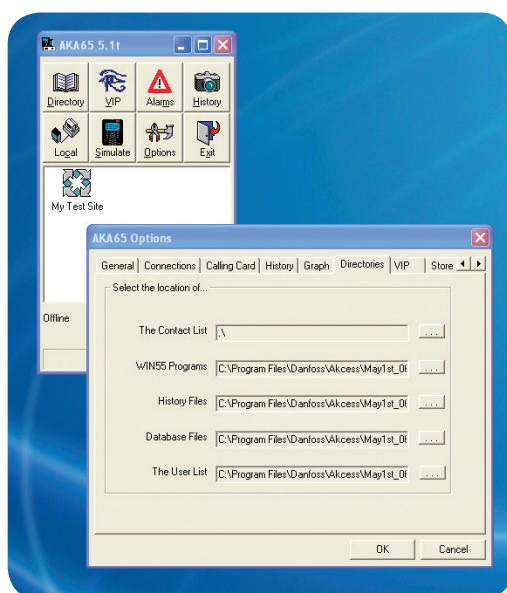

The WIN55 file is represented as a icon and is program that the AKA65 uses to run the AK-SC255 environment. Ensure that the AKA 65 directories points to the folder that holds this file. The 'R' version of the AK-SC255 is denoted by the file name 'VRxx\_xxx.exe'

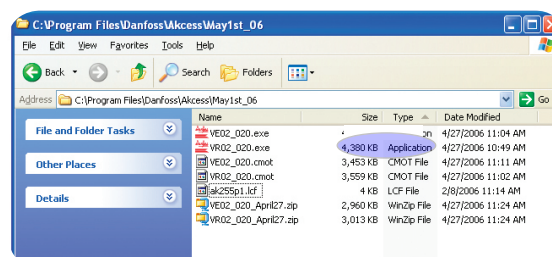

- Close the options dialog box and click on the Simulate Icon. Select the icon 'None' in the database pane, and select VRxx\_xxx.exe. Select the RUN button and a new / blank AK-SC255 database will start.

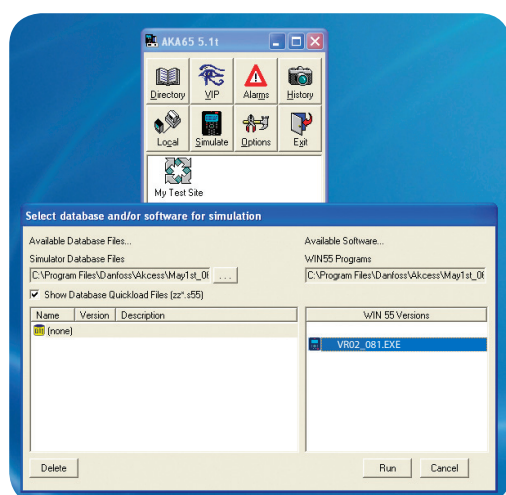

See the Appendix section with details on how to save / load AK-SC255 database files.



## System Screen Navigation

The AK-SC255 system has been designed to allow access to all major parameter sets in the Danfoss range of controllers. To accommodate the potential vast array of parameters, the AK-SC255 employs the use of a simple, user friendly navigation system. Once familiar with the major key actions and combinations, fast and effective navigation of the AK-SC255 screens will follow.

The image below describes the three main 'zones' that make up key areas of the AK-SC255 screens.

**Drop down controller selection**  
- Used to quickly select another controller from the network.

Use the direction arrows to jump between the main screen 'zones'

**Main controller details**  
- Contains all the main parameter and Function groups

**Short cut Icons**  
- Use these Icons to jump to other areas of the controller setup or system

ID	Description	Value	Status
1	Case 1	6.1 (s28)	Ambient

Evap Summary	Measures
--- EKC State	(s28) Ambient
u17 Ther. air	6.1 °C
u18 Ther.runtime	255 min
u19 S1 temp.	-17.9 °C
u09 S5 temp.	31.6 °C
u23 AKV OD %	0 %
u10 DI1 status	OFF
u20 S2 temp.	3.8 °C
u56 Display CPT	8.0 °C
u13 Night Cond.	OFF
u21 SH	21.7 °C
--- Light	On

### Main keys and their function

**Page Tab Icon**  
This indicates that there are more pages of information to display. The current progress is indicated by a yellow bar.

**Function Keys**  
Toggle between Measurements / Settings  
Daily User 'Manual override'

**Escape**  
Use to exit current screen(s)

**Prev / Next**  
Use to jump to the previous or next controller on the network, whilst still maintaining the current view screen

**UP , Down, Left , Right keys**  
Use the main arrow keys to navigate through the various screens in the AK-SC255.

**Menu**  
Use directly jump to main menu

**Page up / Page Down**  
Use scroll through main controller details page

**Edit Key**  
Used to change settings / parameters

**Shift Key**  
Used in combination with the arrow keys to activate the 'Page Tab'

### How do I get the page bar to move - so I can scroll to the next function menu?

You will only see the page tab icon when you have sufficient system password privileges. To navigate through the controller functions use the following key combinations:

Press (then release) the shift button - then press the right or left arrow key. Continue this key combination to navigate through the controller parameter function menus.

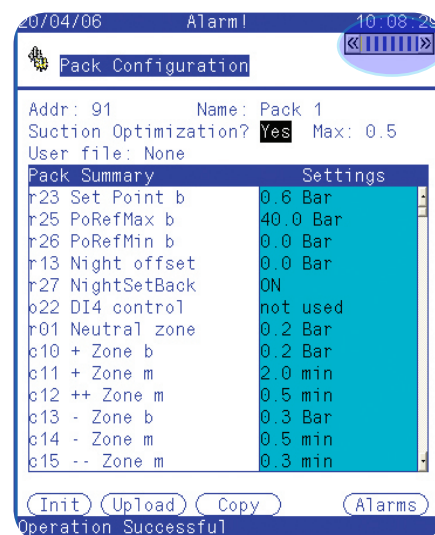
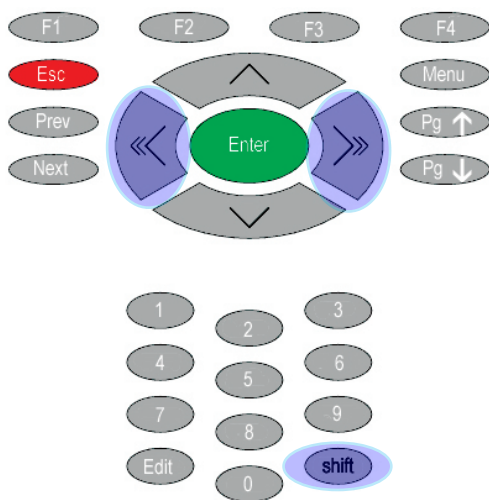

### How do I change setpoints and controller parameters?

You will only be able to change setpoints when you have sufficient system password privileges. Navigate through the controller functions and locate the required parameter that needs changing - the parameter will be highlighted by the system cursor (black line). Press the Edit key once to bring focus onto the parameter, use the numerical keys to enter new value & press Enter.

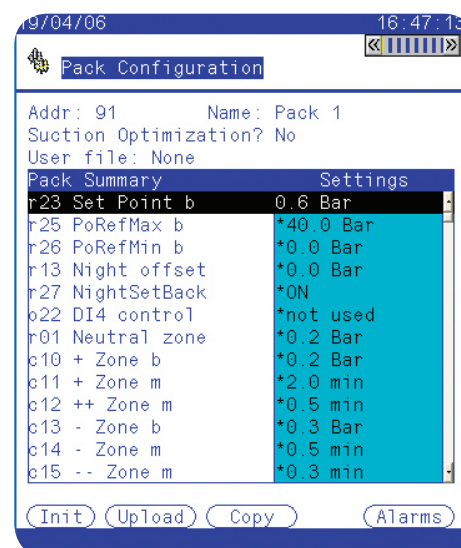
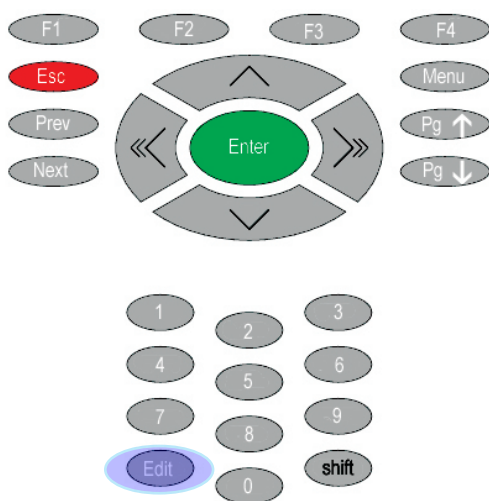

## How do I update the AK-SC255 with new software files?

It is possible to update the AK-SC255 with new and enhanced support files. Typically the AK-SC255 uses software files to provide a high level of controller access and visibility within the system. In order to fully and accurately support EKC and AK2 controllers, files that contain specific controller information need to be present in the AK-SC255.

The controller support files are known as EDF files (Extended Definition Files) and these are made available from the Danfoss factory. Each controller type needs an EDF file corresponding to the controller software version. To facilitate full support, ensure the EDF file also contains compatibility for the software version of the controller - details can be found via the Danfoss factory.



### Loading EDF controller files into the AK-SC255

Establish AKA65 connection with the AK-SC255

Under the File Menu, select Load File...

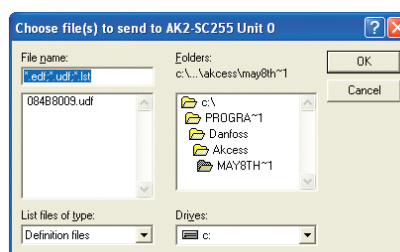

Locate required file(s) and select Ok

The files will be downloaded into the AK-SC255

Use the above method to also update the 'device.lst' file (also available via the Danfoss factory). The 'device.lst' file is also needed to ensure full controller support.

## How do I save my online or off-line AK-SC255 database file?

Using the same method above, navigate to the file / Save Database... menu. Select your required file name and save. This operation fully backs up all the AK-SC255 database and thus all system setup and commissioning values. Later this same function can be used to load a saved database into the AK-SC255. Simply choose 'Load Database...' option to restore to the saved file. This operation requires system password privileges.

## Board & Point setup (AK2 I/O Modules)

A major feature of the AK-SC255 is that in addition to the Generic network support, flexible AK2 I/O modules can be installed adding extra Input/Output functions. The following section details how the address scheme works, and how to program the AK-SC255 for AK2 I/O.

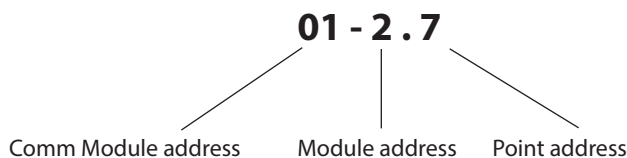
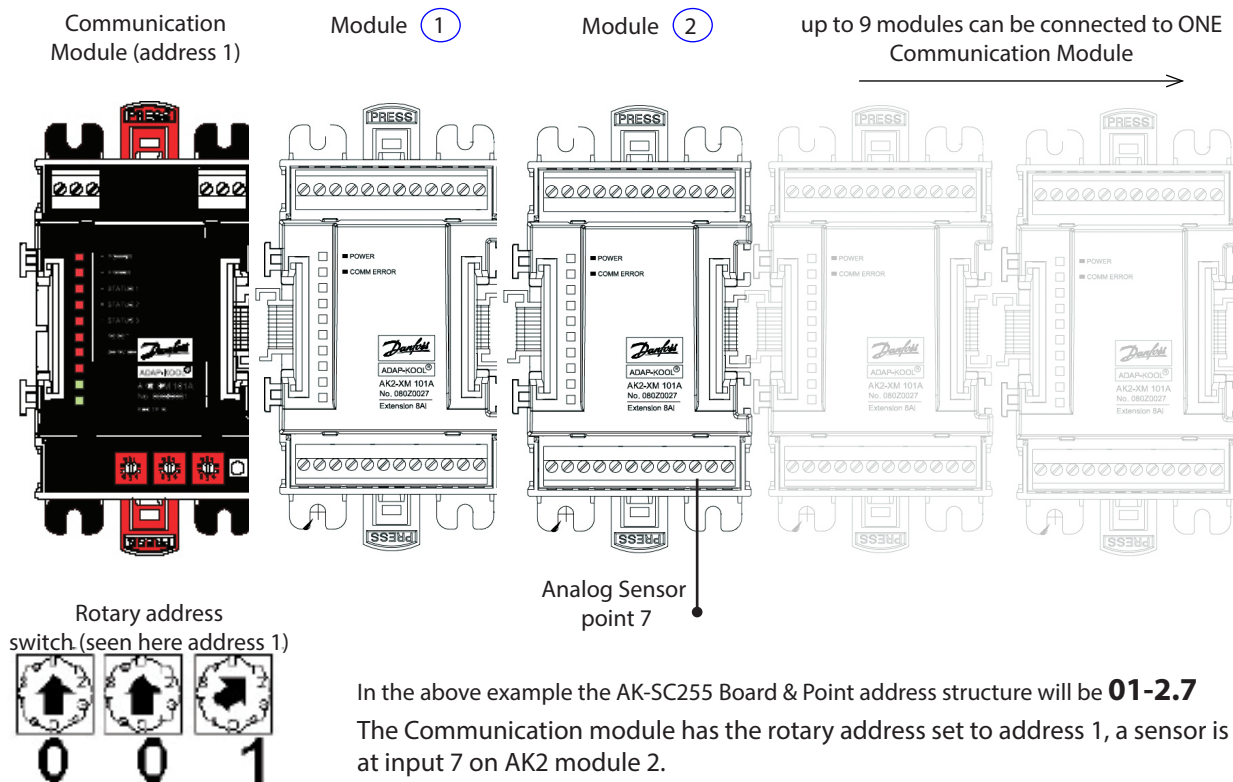

No matter what the address is set on the communication module the first connected AK2 module will assume the address 1.

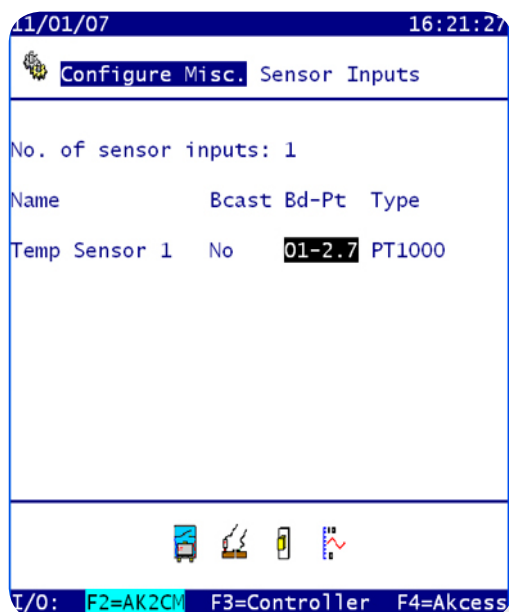

In this example, when programming the AK-SC255 simply type 0127 and the format will be automatically set for AK2 I/O.

In the instance of AK2 'Combo' modules (both Analog & Digital on the same module) the same address can be used. In the above example, 01-2.7 can also be the address for a digital input (entered in the digital input screens of the AK-SC255).

# AKA65 System Support Software Tool

AKA65 is a Windows® PC software tool that allows the user to fully interface with the AK-SC255, and also facilitates full off-line programming of a AK-SC255 database. Once installed on a PC, AKA65 offers the same user interface as is seen at the local AK-SC255 screen so there is limited learning curve on it's use. The AKA65 software tool allows the user the following benefits;

### Remote connection to on site AK-SC255

- Connect via modem, Serial RS232 cable or Ethernet
- View and access all system areas (full read / write)
- Remotely load support files
- Save AK-SC255 configuration
- View / Acknowledge Alarms

### Off-Line programming

- Create a complete site configuration (add controllers, schedules, logs....) without attending site.
- Save created database to later load in AK-SC255 on site

### Simulation

- Load previously saved AK-SC255 database and view setup
- Simulate Boolean logic / miscellaneous points (slide bars to force parameter changes)

### Installing the AKA65 software

The following section details the simple steps in installing AKA65 on a PC.

1/ After inserting CD click 'Next' to continue installation

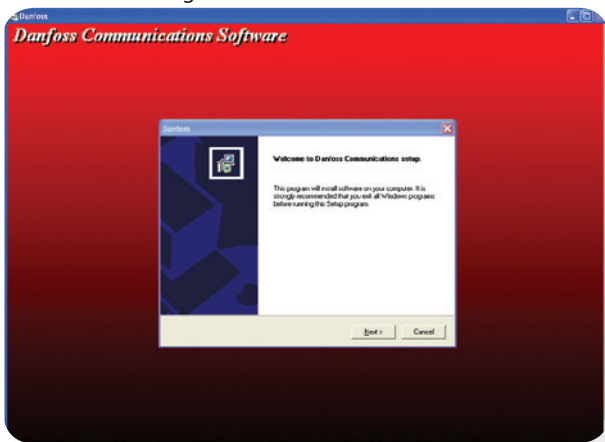

2/ Access Only will install the AKA65 only - recommended

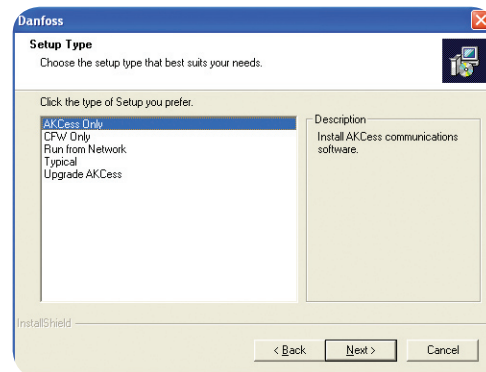

4/ The Win255 module is the software component that runs the AKA65 windows software - select the following folder:

*C:\Program Files\Danfoss\AKCess*

3/ The recommended destination folder is C:\Program Files\Danfoss



5/ Select AK-SC255 executables

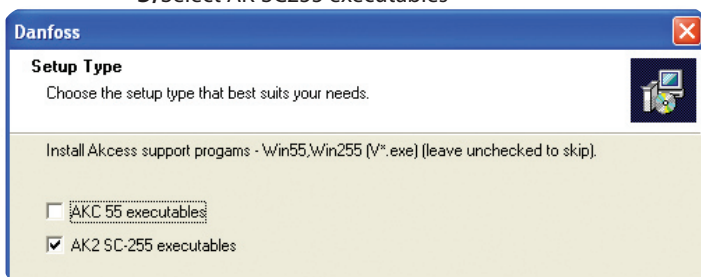

7/ Select folder for EDF files (recommend C:\Program Files\  
Danfoss\AKCess)

6/ Click 'yes' to install EDF's Select AK-SC255

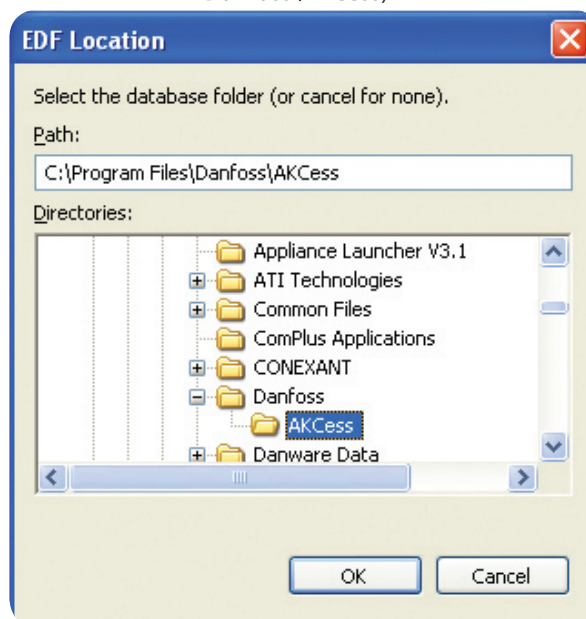
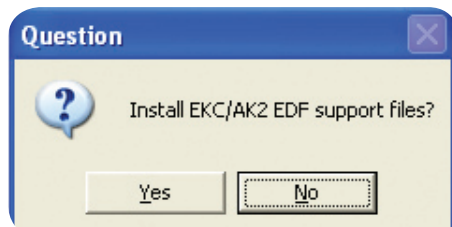

The installation procedure just described will have installed the remote AK-SC255 software tool, AKA65. This software package will now allow the user to fully interact with the AK-SC255 system. The following section describes how to connect to a AK-SC255 via serial or IP communications and then describes the method on how to extract and view history data.

### Connecting to a AK-SC255 via AKA65

There are three main methods on which the user can remotely connect to a AK-SC255 unit, Modem, Serial RS232 and Ethernet IP. Before attempting to connect, ensure the AKA65 has been configured for the correct com port usage. The following example describes the steps in configuring the users PC for modem, Serial or IP use.

Start the AKA65 software and continue by clicking the options button. The General tab displays user selectable options, configure as required (leave as default if not changes needed).

Select the Connections tab to configure the required method of connection to the AK-SC255.

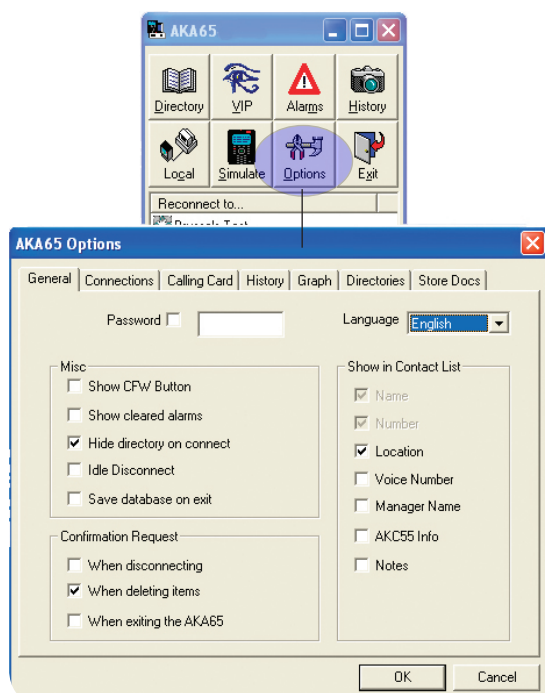

### Connections Tab: Modem, Serial, Ethernet setup

Local COM port: If using serial cable to connect to AK-SC255 select the required local (PC) COM port. If using Ethernet (IP address of AK-SC255), selection this option at the bottom of the drop down list. Enter the IP address of the AK-SC255 when adding a new contact (described later in this chapter)

To synchronize the PC clock with the AK-SC255 check the Time Zone Sync box.

Modem Settings are also found in this menu.

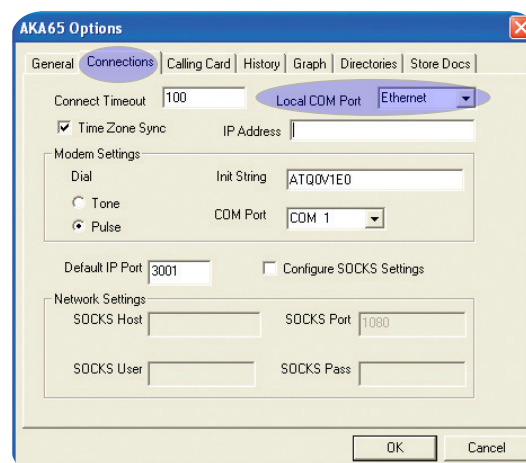

### History Tab:

Contained in the History tab are the settings to enable automatic history retrieval. If the 'Enable' check box is selected then (depending on the chosen parameters) history that has been defined in the AK-SC255 will be harvested and stored on the remote PC for later viewing.

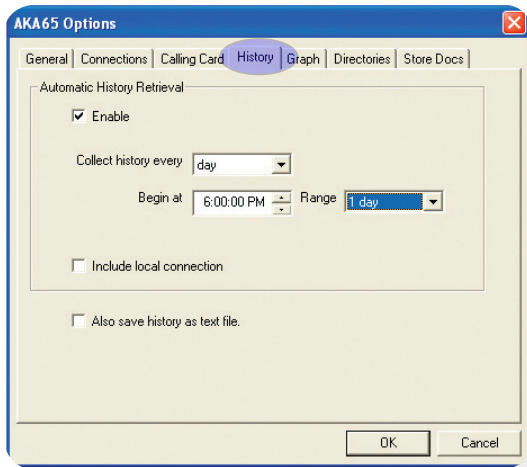

### Directories Tab:

The Directories tab allows the user to define where the AKA65 software 'looks' for important files to allow offline programming, remote-AK-SC255 connection and where saved database files are kept.

#### Contacts List

Location of any stored 'Contacts' (store name, modem number /IP settings)

#### Win55 Program

Location of stored Win55.exe files. The Win55.exe files allow the AKA65 to run on the PC and are required for correct operation. The Win55 files are also used for running the AKA65 in simulation mode. Different versions of Win55 modules can be stored on the PC. Ensure the latest Win55 files are installed on the PC to ensure a file 'match' when connecting to a AK-SC255

#### History Files

Location of any stored history files that have been collected (manually or automatically)

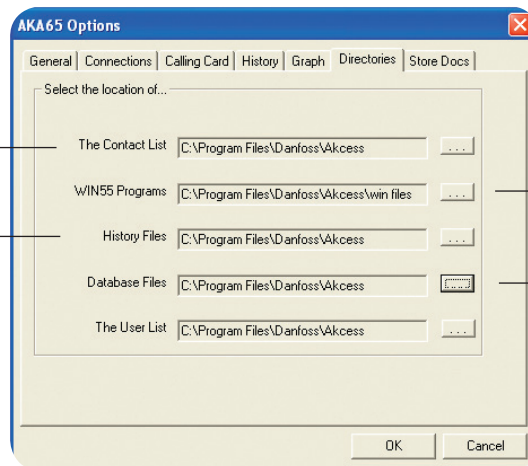

#### Database Files

Location of AK-SC255 database files stored on the PC.

#### The User List

Location of any saved user lists



## Creating new Contacts (Site Name, Modem phone number or IP address)



To create a library of site connections, use the Directory button on the AKA65 main menu. Once selecting the Directory button the user will be able to assign a site name, location, manager details, modem number or IP address. Click on the **ADD** button at the bottom of the screen to add a new site contact details.

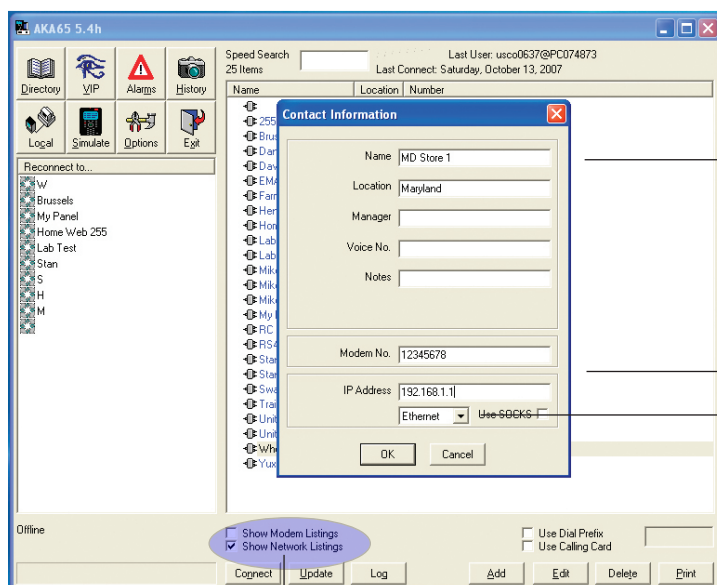

Recommended minimum information

- Name**  
will display this name in the main AKA65 screen after creating
- Location**  
For additional reference only
- Modem No.**  
Modem phone number (if relevant)
- IP address**  
IP address of the 'Master' AK-SC255
- Connection method**  
Ensure the correct connection method is selected

### 'Show' Connection method

Depending on this check selection, the contacts list will display either modem sites or Network (IP sites)

## Retrieving History



The following section describes the steps in retrieving history data that resides in the AK-SC255. Upon retrieving the history data, analysis and detailed graphing can be made on the remote PC, using the AKA65.

From the main AKA65 menu connect to the site that requires data retrieval. Once connected to the remote AK-Sc255, click on the History button on the main AKA65 menu.

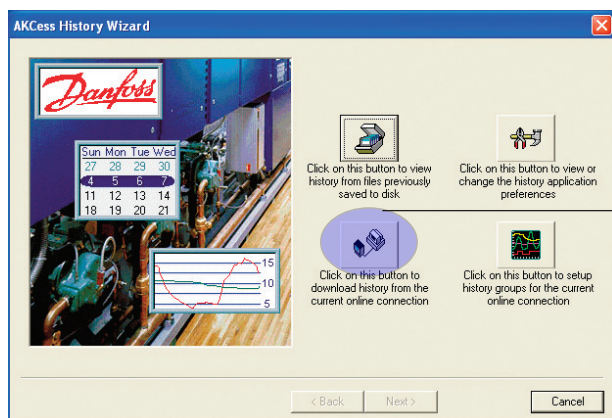

For this example, select and click the button that collects the history data via an on-line connection. This pre-pairs the process of pulling back the stored history data in the AK-SC255. The following screens will ask for data point selections and time retrieval periods.

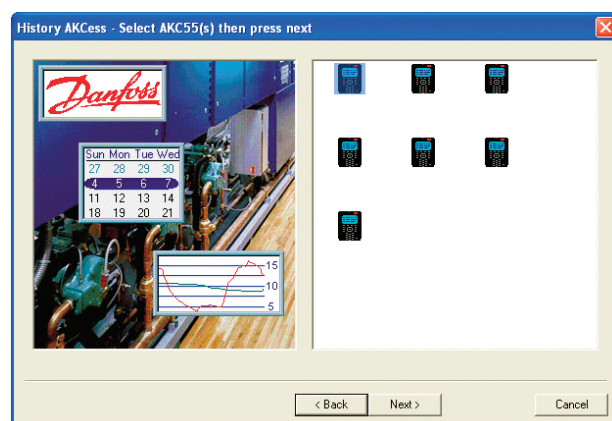

This examples shows a site that has multiple AK-SC255 units connected (known as a host network). At this screen any of the units can be selected to have data retrieved. Select the AK-SC255 icon and click 'Next'

Once the history data in the AK-SC255 has been analyzed a datapoint selection page is shown. Choose which datapoints are to be shown in the resulting graph or table.

Use the ADD arrow key to make the selection. For speed, use the ADD All tick button - that will select all the datapoints and add them to the list to be extracted.

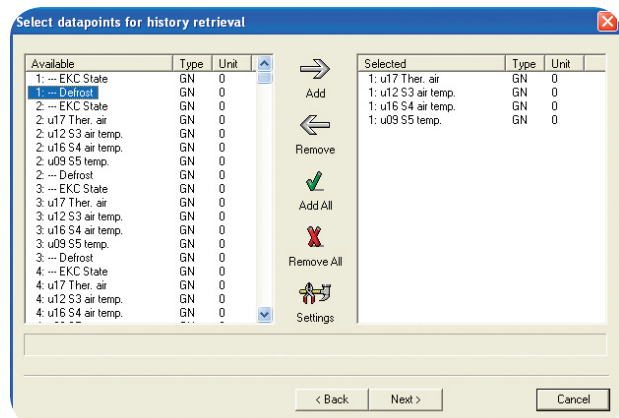
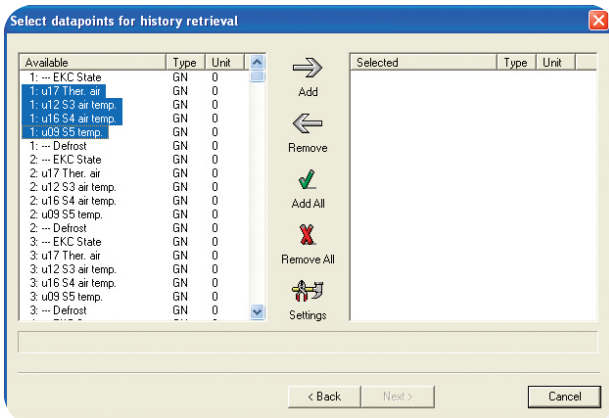

Select the Start and End time/date for the data retrieval period. This will initiate the collection process from the AK-SC255 to the AKA65. A status bar will appear to display downloading process and progress.

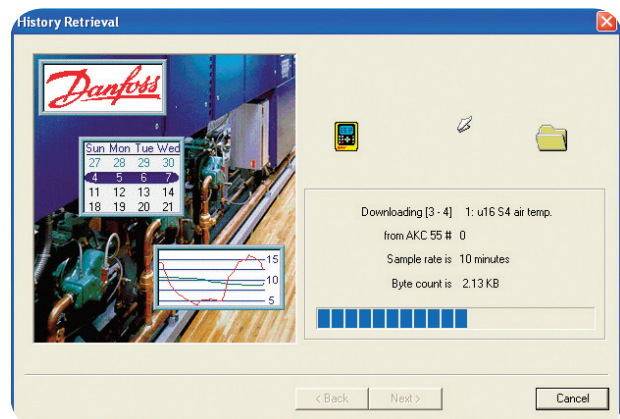
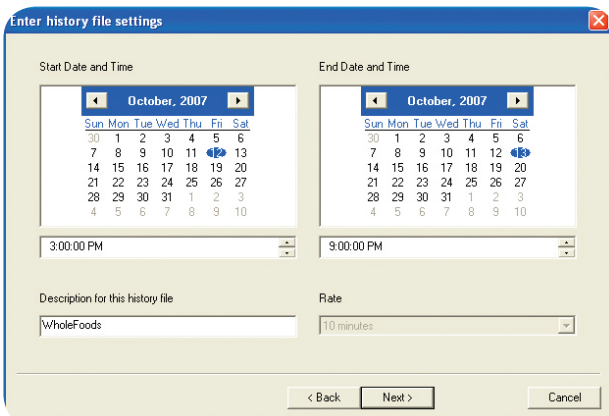

Once the datapoints have been collected, select which of the parameters will be displayed in the resulting graph or text table. Choose the Start and End time / date for this data to be displayed.

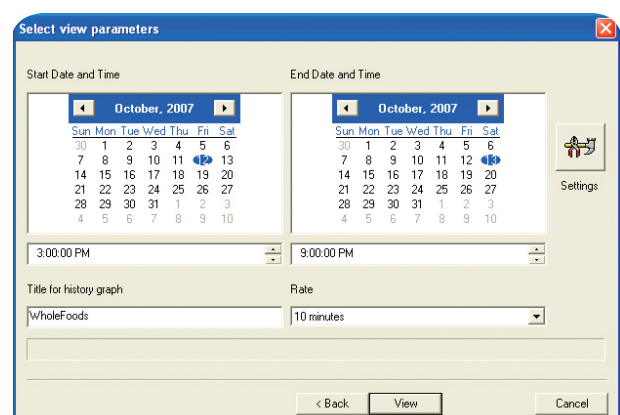
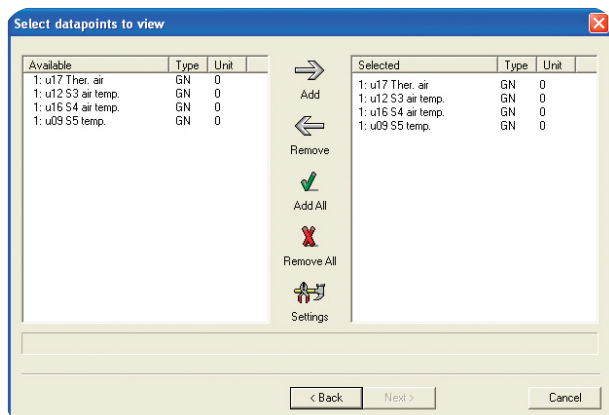

Click the View button to see compiled graph

The resulting graph will display the selected datapoints, previously configured. To Zoom into any section of the screen, use the left hand mouse button, click & hold & release. At the top of the graph bar is a selection of tools that allows the user greater control over the graph, hover over the buttons with the cursor to see a pop up description box. In the example screen blow, the 'Data box' button has been used to display a table form of the graph. From this table, select 'Datasheet' to export the graph data to a spreadsheet program installed on the PC.

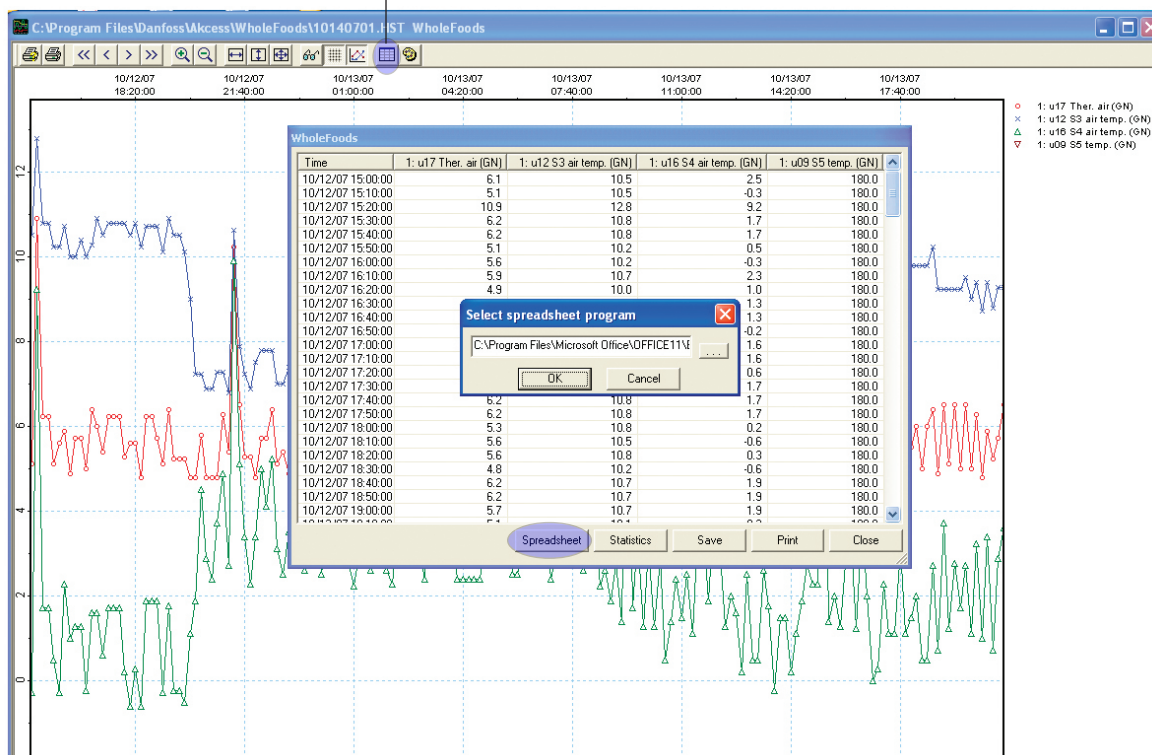

Once finished with viewing the graph/table close down the program. All the data has been saved to a file on the PC, to view this data set again, select the History button again from the AKA65 main menu. Next, select the button that refers to viewing data from previously saved files, this will open up a selection window to allow the file to be selected.

## Loading AK-SC255 software and system files

Code downloader software version 4.1 is a software PC tool that, once installed, allows the user to update the AK-SC255 software. Danfoss periodically issues new system software files to update & enhance system functionality. Codeloader version 4.1 allows the loading of AK-SC255 system files via either a serial or Ethernet connections and also offers support for the new file extension '.mai' (Master Application Image). The .mai file format offers the advantage of a single file that includes system application code, EDF & HTML files, thus simplifying the upgrading process. This section also includes instructions on using a USB flash memory stick, when updating using the new mai file format.

## Installing and getting to know Code Downloader V4.1

Once the 255Load4\_1.exe file has been downloaded to the target PC, double click to run the application. The Danfoss Code Downloader requires Windows® XP or Vista to be installed. The Code Downloader PC tool is an easy to use application that enables the upgrade of Danfoss AK-SC255 systems. Once running, the application presents a simple interface, as shown in figure 1.

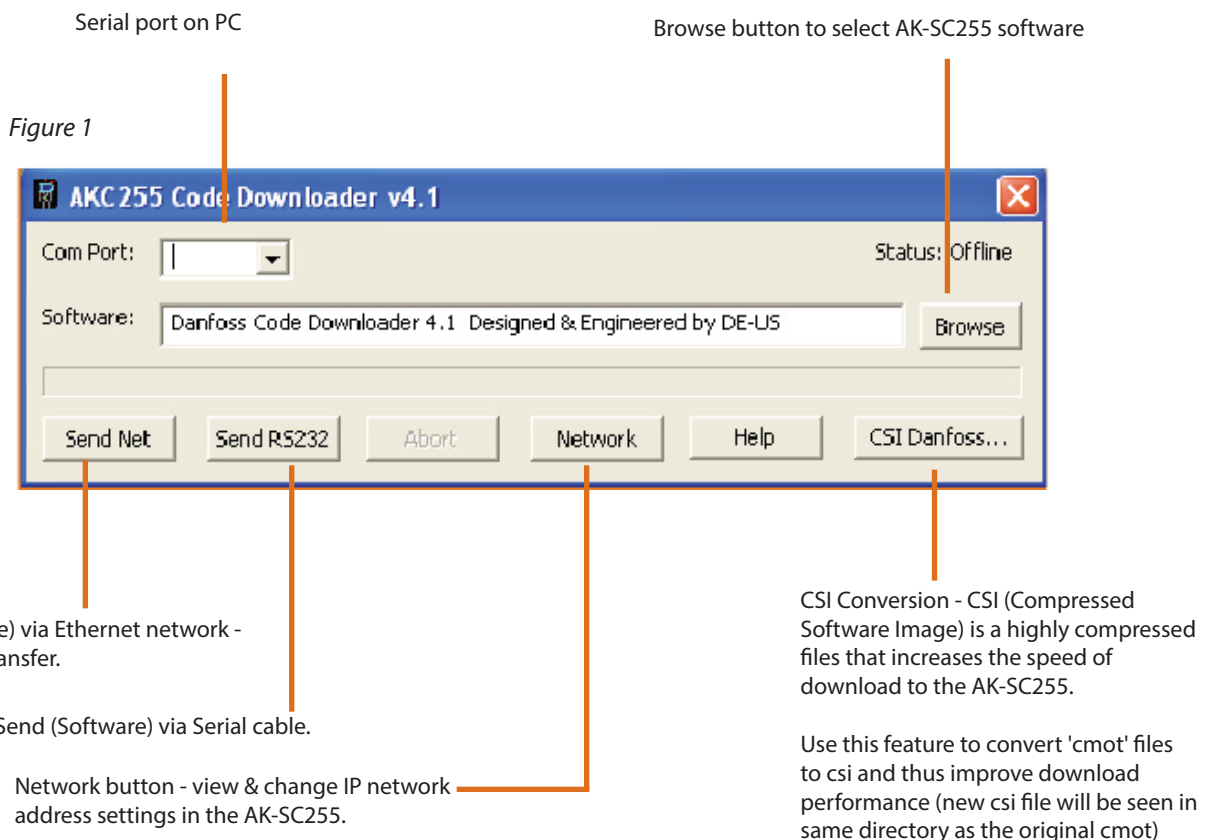

## File Types & Usage

The AK-SC255 utilizes various system files and software in order to operate correctly and provides support for various network devices. Table 1 describes the various files and their use.

**Table 1**

File	Description
<b>Bootloader</b> [Use Codeloader or USB to update this file]	The Bootloader file is the initial file that is installed when the AK-SC255 starts. This file contains instructions for the AK-SC255 on how to manage flash memory & board level communications. This file must be present for correct operation.
<b>Device List</b> [Use AKA65 to update this file]	In order for the AK-SC255 to support generic devices (AK & EKC), suitable EDF files are required. Each controller model & type has it's own EDF file which describes to the AK-SC255 the full parameter layout. The Device List (device.lst) is the master table of contents for the EDF files
<b>EDF files</b> [Use AKA65 to update this file]	Extended Definition Files - used to map controller parameters & key variables to the AK-SC255. EDF files should reside in both the AK-SC255 and the connected PC (AKA65)
<b>HTML files</b> [Use FTP tool (Filezilla)]	These files are found under the AK-SC255 directory E: HTML files are pre loaded from the factory. The E version AK-SC255 has a simple daily user web page and the HTML files provide this function
<b>Application code</b> [Use Codeloader or USB to update this file]	The application code is the main operating software that provides the features / functions for AK-SC255 operation & Control. Typically when Danfoss issues AK-SC255 updates, the files will be labeled as 02_101.csi. (02_101 indicating the release version). Information from Danfoss is available that highlights the new features added in each new software release.
<b>Master Application Image (mai)</b> [Use Codeloader or USB to update this file]	The .mai file is a single file that combines the Application code, EDF's, Device list & HTML files. The combining of all the key system files facilitates an easy upgrade process and is new for 02_101 and beyond. Bootloader files should be loaded separately and are not part of the mai.

## Upgrade options

In accordance with Danfoss's policy for continuing improvement and development, new software is released on a scheduled basis. The following section describes the different upgrade techniques and processes.

Figure 2 highlights the three main options (A, B & C) when updating the AK-SC255.

**Option A** shows the various required files that typically get updated in the AK-SC255 when a new software update is issued. Seen as light grey, the Device list, EDF and HTML files are loaded via the AKA65 tool. Depending on AK-SC255 version, all four file types will need to be updated. The Application code is loaded via the Codeloader tool. In each example the AK-SC255 Bootloader is required to be installed before any upgrade can continue. As option A suggests, to upgrade the AK-SC255 multiple files need to be downloaded using AKA65 and Codeloader respectively.

**Figure 2**

### Option A - use Codeloader & AKA65



### Option B - use Codeloader



### Option C - use USB Flash drive\*

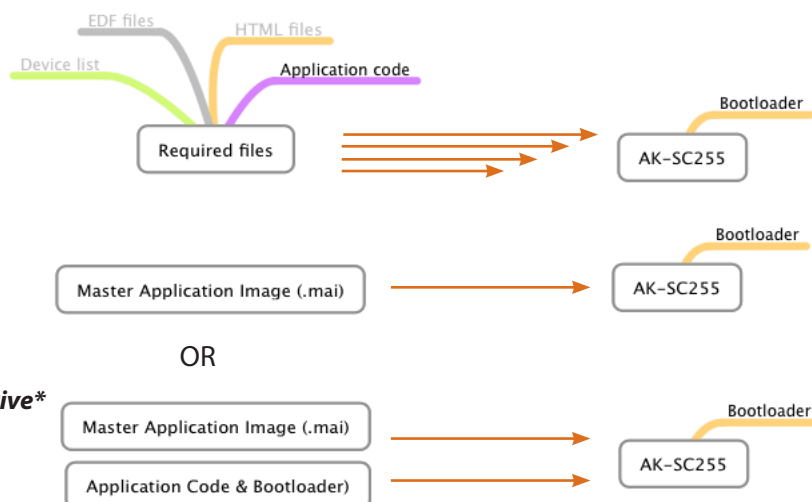

\*Loading via USB requires AK-SC255 V1.2 CPU card & above. Bootloader 6.1 must have already been installed.

**Option B** sees the use of the (new) .mai file, which includes EDF, Device list, HTML and application code all in one file. Use the Codeloader tool V4.1 to download the .mai file.

**Option C** uses a supported USB flash drive, which holds the .mai file. When inserted in the USB port the on screen prompts will allow the loading of the mai file. In order for the USB upgrade to function correctly the following important points must be observed;

- Version 1.2 CPU card is required
- AK-SC255 with USB connector
- Bootloader V6.1 pre-installed
- Application version 02\_101 and above support mai format
- .mai file must be located in the USB root directory (not located in sub folders)
- Only the highest application version will show in the options window
- Only compatible versions of application will be shown in options window (if R code is installed in the AK-SC255, only R versions will be shown, even if other AK-SC255 version types are present)



How can I tell if my AK-SC255 has version 1.2 or above CPU?

To determine if version 1.2 CPU card or above is installed, refer to the product label (located on the right hand side of the screen unit).

The two digits preceding the characters BJ (figure 3 - shown in orange) must be 10 or greater. Any digits lower than 10 will indicate that a CPU card version less than 1.2 is installed. Version 1.2 CPU is required in order to use option C loading (master application image).

**Figure 3 - Identifying if AK-SC255 has compatible CPU card - in this example, the digits 10 identifies a CPU V1.2 or above is installed**

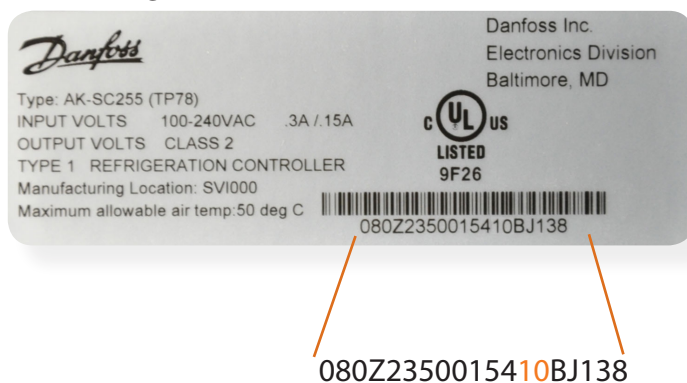

## Upgrade procedures

### Option A - (using Codeloader to update AK-SC255 application i.e. V02\_101.cmot)

All current software releases contain the options of cmot, csi and mai file types (see figure 4) and for option A, where possible the csi file should be used. The .csi format is a compressed version of the cmot and offers faster download times. Bootloader version 5.1 or above must be installed as a prerequisite. Install bootloader 5.1 or above before starting the upgrade process.

*Note: The Code Downloader offers a conversion button that will take a cmot file and create a csi, use this feature for older upgrades lower than 02\_081, where a csi was not originally issued by the factory. Skip this step if the intended upgrade code already is seen in .csi format (02\_081 and above).*

**Figure 3 - current software releases are offered in 3 formats**

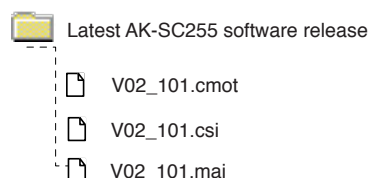

Using Ethernet is the fastest way to download new firmware, taking just a few seconds. In order to prepare for this method, both a serial & Ethernet connection must be made to the AK-SC255. The AK-SC255 should have a valid IP address that is in the same net range as the PC that will load the code. Once both PC & AK-SC255 have valid IP addresses, connect a serial cable (Danfoss # 080Z0262) to the AK-SC255 and the connecting PC. The following steps highlight the procedure for using the Ethernet method;

- Ensure AK-SC255 & PC has valid Ethernet & Serial connections
- Remove jumper JP2 (next to the service reset button on the AK-SC255 PCB - *New style AK-SC255 box units*)
- Re-Set AK-SC255 & World map should be displayed (Valid IP address should be shown on this screen)
- Open Codeloader V4.1
- Select the correct (Serial) com port used on the PC to connect to the AK-SC255 (see figure 4)
- Browse for relevant software file i.e. Vx02\_101.cmot (see figure 4)
- Select the 'Send Net' button & Observe download progress

**Once complete, replace jumper & re-set AK-SC255** - New firmware will now be displayed in the AK-SC255. If Ethernet connectivity is not available, a serial only method can be used on site. Codeloader V4.1 allows a 'point to point' connection to the AK-SC255 & PC via the Danfoss cable (080Z0262).

The following steps highlight the procedure for using the serial connection method;

- Ensure there is a connection between the AK-SC255 and PC using Danfoss cable 080Z0262
- Remove jumper JP2 (next to the service reset button on the AK-SC255 PCB- *New style AK-SC255 box units*)
- Re-Set AK-SC255 & World map should be displayed
- Open Codeloader V4.1
- Select the correct (Serial) com port used on the PC to connect to the AK-SC255
- Browse for the software file (i.e. Vx02\_101.cmot)
- Select the 'Send RS232' button & Observe download progress

**Once complete, replace jumper & re-set AK-SC255** - New firmware will now be displayed in the AK-SC255

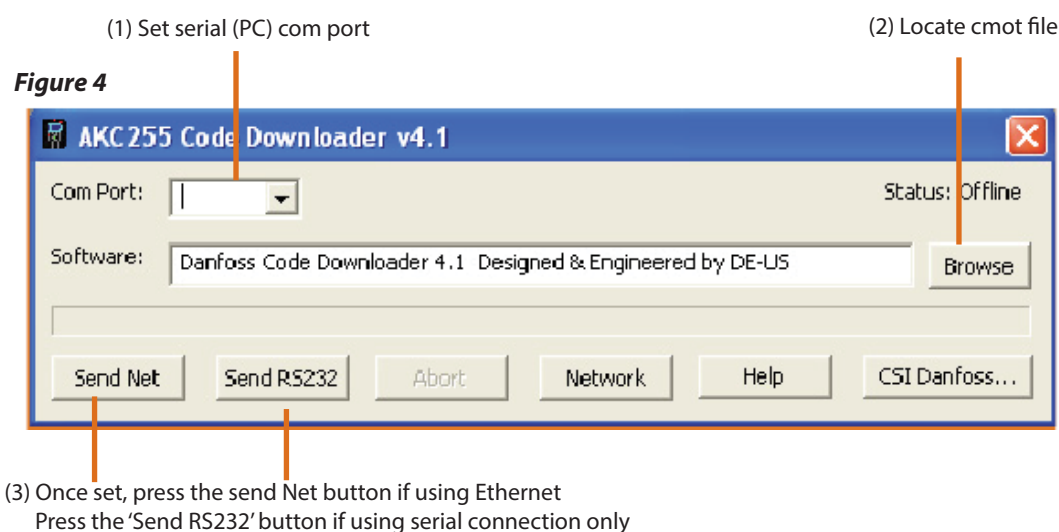

#### Option B - (using Codeloader to update AK-SC255 application i.e. V02\_101.mai)

The new Master Application Image file (.mai) contains all the required files for AK-C255 upgrade, in one main file. This simplifies the upgrading process as only one file needs to be updated. Using the same steps as describes for Ethernet download, ensure a connection to the AK-SC55 has been made and using the browse button to select the required .mai file.

**Option C - (Using USB Flash drive to update AK-SC255 application i.e. V02\_101.mai)**

Having ascertained that the AK-SC255 to be upgraded complies with the minimum requirements set out in section 3, a USB flash stick can be used in the upgrade process. Upon insertion of USB memory stick a user menu will appear. Table 3 captures the contents of the on-screen menu and provides additional comments on each option. Not all the options shown in table 3 will be available and will be dependant on what files are available on the USB stick. Before continuing the upgrade process, consult with table 2 below, and note any applicable exceptions.

**Table 2 - Limitations & Operation notes**

Limitations & notes
The options shown in table 3 are only available when using CPU cards V1.2 and above. Bootloader 6.1 and above must be pre-installed
'Hot Plug' is not supported. If the USB disk is connected to the AK-SC255 when the unit is booting up it (USB) will not be detected. Insert USB during normal run time operation or when in Bootloader mode
All software and files to be loaded must be placed on the USB root directory. Files that are inside sub folders will not be detected
Only the highest version of the software will be available for upgrade and shown in the menu
Only compatible versions of Application & .mai files will be displayed. When upgrading the AK-SC255, only 'same category' code base will be accepted, I.E. if the original AK-SC255 is installed with R (Rack) version code, the system will not permit loading of AK-C255 E version.
If the AK-SC255 is in screen saver mode, the insertion of the USB stick will not wake the screen, press any key to expose the USB menu

Upgrading via USB can be done either in Bootloader mode or in normal operation mode. In Bootloader mode the system berg jumper is removed and the AK-SC255 unit re-set, resulting in Bootloader mode. Upon inserting the USB stick a menu selection will appear, shown in figure 5. Follow the on screen instructions for either operation mode.

**Once all code loading is complete, replace jumper & re-set AK-SC255**

**Figure 5 - typical USB menu in Bootloader mode**

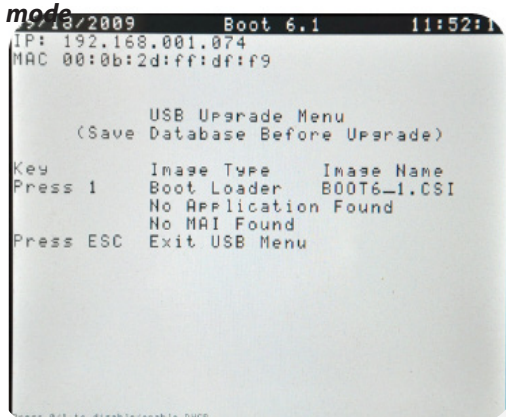

**Figure 6 - typical USB menu in normal run mode**



**Table 3 - Keypad options via menu on local screen - Dependant on available files on USB**

Keypad option	Task	Software	Comments
PRESS 1	Upgrade the Bootloader	BOOT	
PRESS 2	Upgrade the AK-SC255 application	Latest application software	
PRESS 3	Upgrade the master application (MAI format)	Latest master application software	.mai format (includes EDF, device list, HTML, application).
PRESS 4	Load database	Latest database	Available in normal run mode only
PRESS 5	Save a database	.S55 format database file	Available in normal run mode only
PRESS 6	Save a system report	.txt format	AK-CS units only



## Upgrading DIN versions

Utilizing the LED lights seen on the DIN AK-SC255 model, it is possible to use the USB method to update system code and files. The JP2 berg jumper and rotary address switch are also used in the process. Table 4 reflects the LED patterns

LED #	LED State	Selection
1,2,3,4,5,6,7,8	ON,OFF,OFF,OFF,OFF,OFF,*,*	1: Boot loader Upgrade
1,2,3,4,5,6,7,8	OFF,ON,OFF,OFF,OFF,OFF,*,*	2: App Upgrade
1,2,3,4,5,6,7,8	OFF,OFF,ON,OFF,OFF,OFF,*,*	3: MAI Upgrade
1,2,3,4,5,6,7,8	OFF,OFF,OFF,ON,OFF,OFF,*,*	4: Load Database
1,2,3,4,5,6,7,8	OFF,OFF,OFF,OFF,ON,OFF,*,*	5: Save Database
1,2,3,4,5,6,7,8	OFF,OFF,OFF,OFF,OFF,ON,*,*	6: Save Report (available only in CS)

### LED patterns:

- 1) Incremental Running LED's ( 1 -> 5) indicating that a USB device has been detected
- 2) Decrementing Running LED's ( 5 -> 1) indicating that there is a data transfer going on between the USB disk and the AK-SC255 unit
- 3) When all the LED's 1-5 are ON it indicates an error while downloading.
- 4) LED 1-6 Indicate a particular selection, the selection is valid only when berg pin is on
- 5) LED 7 & 8 blinking alternately indicates unit is in boot loader mode
- 6) LED 7 blinking and Led 8 ON indicates unit in application mode.
- 7) LED 6 blinking indicates downgrade warning (the user is trying to move from a higher application to a lower application so database will be deleted)
- 8) After a successful upgrade when the unit comes back up the unit will have LED 6 ON indicating successful upgrade
- 9) If LED 6 is blinking after a boot up in App mode, this indicates extraction of support files from the MAI images failed
- 10) If LED 8 is toggling on and off it indicates extraction of support files from the MAI during application boot up just after an MAI upgrade

#### LED Decremental pattern (5 -> 1)

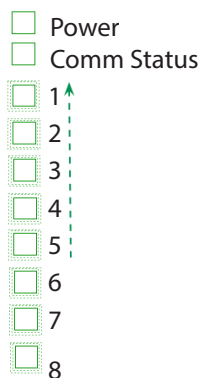

#### LED Incremental pattern (1 -> 5)



## Update procedure

The following steps should be followed while upgrading a DIN unit both in the bootloader and normal run status.

1. Ensure that the unit is either in the bootloader mode or application mode (Note the pattern on Led 7 and 8)
2. Also ensure that the Rotary address switch is in position zero (If the switch is at any different location ensure that it is returned to that position after the upgrade)
3. Connect the USB disk to the unit
4. Ensure that there is an incrementing running led pattern on the LEDs. If no pattern is evident, disconnect and re-connect the USB, repeat until the LED pattern shows.
5. Remove the JP2 berg jumper if connected.
6. Once the USB is detected, make a selection using the Rotary address switch, using the following assignments

Rotary Address 1 = Boot loader Upgrade  
 Rotary Address 2 = App Upgrade  
 Rotary Address 3 = MAI Upgrade  
 Rotary Address 4 = Load Database (Only in application mode)  
 Rotary Address 5 = Save Database (Only in application mode)  
 Rotary Address 6 = Save Report (Only in the CS version)



7. Insert the JP2 berg jumper.
8. Ensure that the LED pattern on leds reflects the selection made. Refer the above table for the correct pattern. (If the Led pattern does not reflect the selection that mean Invalid selection was made.)
9. Check Led 6 if blinking the user is downgrading, ensure that you really want to downgrade
10. If the pattern matches the selection, remove the berg jumper.
11. Position in the Rotary address switch back to position 0, this indicates a confirmation
12. Insert the berg jumper back
13. The led should show a decrementing running led pattern indicating data transfer between USB and the 255 unit.
14. Restore the rotary switch back to the original position before you started the upgrade.
15. If you made a wrong selection or the patterns do not match, Remove the berg jumper and move the rotary switch to position 9 to reset. Ensure that you have incrementing running led pattern and then start all over again.

**After each code / application update or database load (Bootloader, Application, MAI or database) ensure the AK-SC255 is re-set**

## Important notes

- Always move the rotary switch only when the berg pin is removed
- Position 0: Indicates confirmation to process with the operation.
- The LED pattern will be visible only when the berg jumper is on.
- The position of the rotary switch will be read only after the berg pin is inserted back
- Position 9: Can be used like ESC
- If the LED pattern does not match the selection there is a mistake so don't proceed with confirmation
- The Incrementing running led pattern indicate the initial state of the USB Menu
- Re-set the AK-SC255 after each code loading sequence or database load

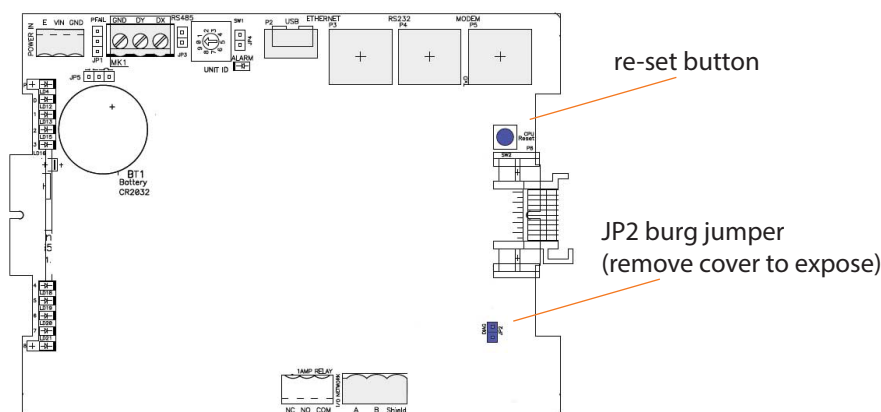

## Industrial Defrost

For Pumped CO2 applications, and other industrial systems, it is critical to wait for all of the liquid CO2 in the evaporator to boil off before heat is applied to the evaporator coil for defrost to begin. If heat is applied while liquid CO2 is still present in the coil, dangerous pressures could be created very quickly.

In cold storage applications, there is no danger of over pressurization of the evaporators but the refrigerating effect of the liquid present in the coil will significantly lengthen defrost times. The pump-out period must be long enough to allow for the removal of liquid refrigerant in the evaporator to ensure a proper defrost cycle.

When the defrost is completed, It is possible to add an Equalize phase in which the Equalize Relay opens up to the suction line so that pressure equalization takes place. This allows the evaporator pressures that may have increased during defrost to decrease or “bleed-off” before refrigeration starts.

### Technical reference

The current defrosting sequence in the evaporator’s algorithm includes defrost and drip down phases. The new industrial defrosting sequence will include the following four phases: **Pump-Out, Defrost, Equalize and Drip Down**. The following figure outlines the output relays (suction solenoid, pump-out, defrost and equalize) states and the EEPR positions during the defrost and refrigeration processes.

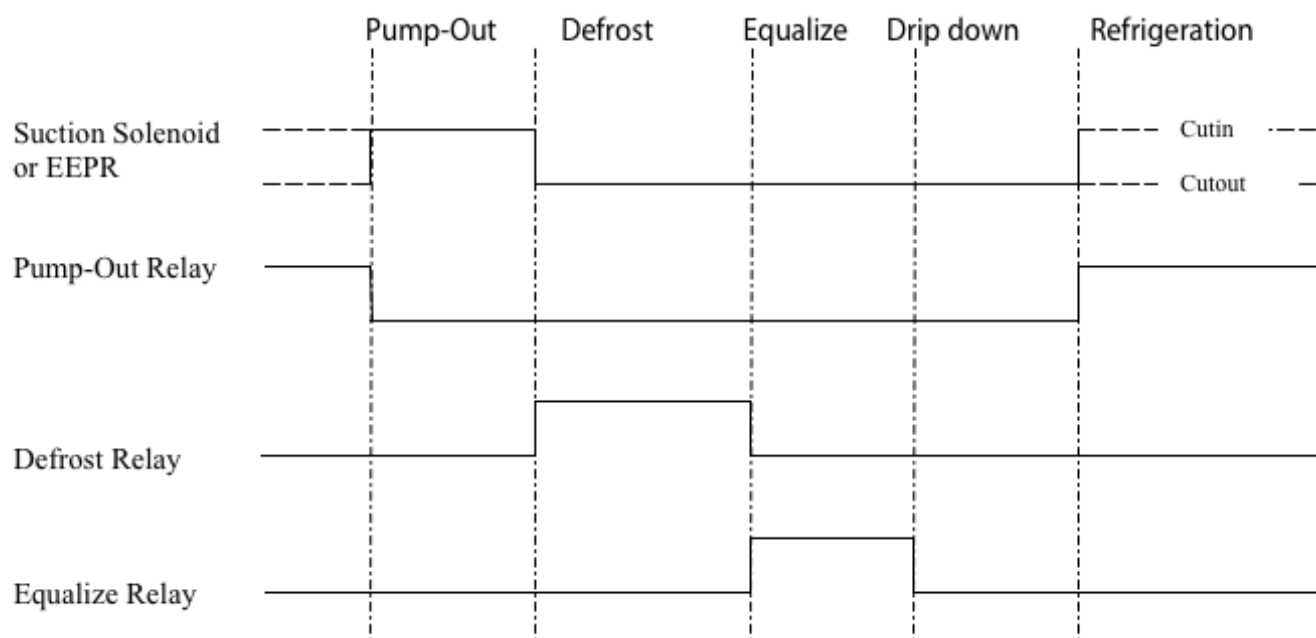

### User Interface and Configuration

In order to make the system more user friendly, a new defrost setup page has been added into the evaporator configuration process.

First, a Yes/No question, “Advanced defrost process?” is displayed in the evaporator configuration page if the following condition is true:

- (1) the temperature control is selected to Solenoid or EEPR and the type of defrost is not None, or
- (2) the temperature control is selected to None and the generate circuit relay is selected to Yes and the type of defrost is not None.

A “YES” to this question will activate the advanced defrost setup page and a “NO” will disable the advanced defrost setup page. In this new page, the AK-SC255 will have two Yes/No questions to enable the Pump-out feature and the Equalize phase.

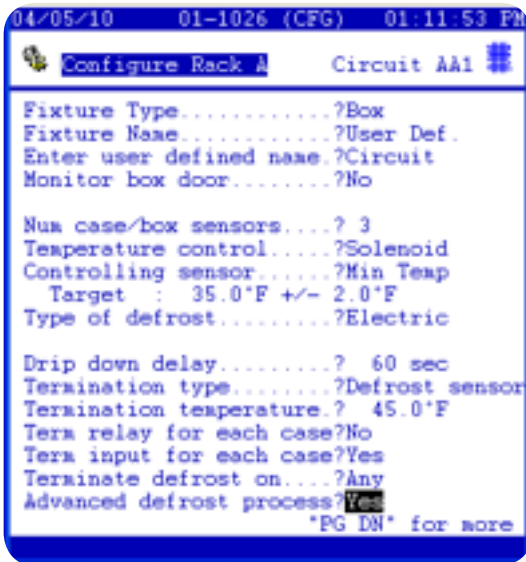

### Activate the Pump-Out Feature

The user can enable or disable the Pump-out feature with selections under the refrigeration control. This will build an additional RO point for a liquid line solenoid, called “Pump-Out” relay. The evaporator status will indicate “**Pump-Out**” during the pump-out period. Add a Pump-Out timer:

Default setup = 15 minutes.  
The range = 0 – 120 minutes.

If the Pump-Out Feature is selected, the Pump-Out relay is closed while the suction valve (solenoid or EEPR) is open for the pump out period, allowing any remaining liquid in the coil to evaporate. This time will be added to the Defrost time, i.e. a 45 minute defrost time with a 15 minute pump-out time added to it, making a 60 minute total defrost. The default state for the pump-out relay is set to **Normal Open**.

### Activate the Equalize Phase

The user can enable or disable the Equalize phase only if the selection of defrost options is **Hot Gas defrost** or **Electric defrost**. This will generate an additional RO point, called “Equalize” relay. The evaporator status will indicate “**Equalize**” during the equalize period. Add an Equalize timer:

Default setup = 5 minutes  
The range = 0 – 60 minutes.

If the Equalize Phase is activated, the equalize phase will energize the equalize relay after defrost is over and before refrigeration is turned back on. This will allow the evaporator to slowly equalize high pressure in an evaporator after a hot gas or electric defrost cycle. The default state for the equalize relay is set to Normal Open.

### Auto Defrost Schedules

If auto defrost schedules is enabled, the “**Include drippdown time**” has been changed to “**Include equalize/drippdown time**” in the configuration of schedules in order to include the equalize time into the schedule time if the equalize phase is enabled.



## The Industrial Defrost Process

The functions of defrost have been modified for the new industrial defrost processing. The modification outlines are given as the following.

From the state machine of the defrost processing:

Check if a manual defrost is true.

If it is true, then set the current state to the pump-out state and start the pump-out timer if the pump-out feature is enabled. Otherwise, set to the manual defrost state.

Check if a scheduled defrost is true.

If it is true, then change the current state to the pump-out state and start the pump-out timer if the pump-out feature is enabled.

Otherwise, set to the defrost state.

For the individual state from the state machine processing:

### In the pump-out state:

- 1). Turn the suction solenoid to ON or the EEPR to 100%, and turn the pump-out relay, the defrost relay and the equalize relay to OFF.
- 2). Check if the pump-out timer is timeout. If the timeout is true, then
  - a). Stop the pump-out timer.
  - b). Check if setup for some type of defrost terminations and it's done, then set the current state to the dripdownd state. No need to go through the equalize phase.
  - c). Otherwise, go to the next state - the defrost state or the manual defrost state.
- 3). Check for manual defrost override. If the manual defrost override is true, then
  - a). Stop the pump-out timer.
  - b). Set the current state to the dripdownd state. Don't need to go through the equalize phase.

### In the defrost state:

- 1). Turn the defrost relay to ON, and turn the suction solenoid relay, the pump-out relay and the equalize relay to OFF (for EEPR to 0%).
- 2). Check if setup for some type of defrosts terminations and it's done.
- 3). Check if schedule is no longer true and need to terminate the defrost.
- 4). Check for manual defrost override.

If the defrost is done or terminated, then change the current state to the equalize state and start the equalize timer if the equalize feature is enabled. Otherwise, set the current state to the dripdownd state.

### In the manual defrost state:

- 1). Turn the defrost relay to ON, and turn the suction solenoid relay, the pump-out relay and the equalize relay to OFF (for EEPR to 0%).
- 2). Check if setup for some type of defrosts terminations and it's done.
- 3). Check if the manual defrost timer is time out and need to be terminated.
- 4). Check for manual defrost override.

If the manual defrost is done or terminated, then change the current state to the equalize state and start the equalize timer if the equalize feature is enabled. Otherwise, set the current state to the dripdownd state.

### In the equalize state:

- 1). Turn the equalize relay to ON, and turn the suction solenoid relay, the pump-out relay and the defrost relay to OFF (for EEPR to 0%).
- 2). Check if the equalize timer is time out. If the timeout is true, then
  - a). Stop the equalize timer.
  - b). Go to the next state – the dripdownd state.

### In the dripdownd state:

- 1). Turn all of the relays OFF (for EEPR to 0%).
- 2). Check if the dripdownd timer is time out. If the timeout is true, then
  - a). Stop the dripdownd timer.
  - b). Go to the next state – the cutin or cutout state depending on the circuit temperature.
  - c). Setup some delay timers.

**In the cutin or cutout state (the refrigeration state):**

- 1). Turn the pump-out relay ON.
- 2). Turn the defrost relay and equalize relay OFF.
- 3). The suction solenoid relay or EEPR depending on the circuit temperature.

**In the shutdown state:**

- 1). Turn all of the relays OFF (for EEPR to 0%).
- 2). Check if the shutdown is no longer true. If the shutdown is false, then go to the cutout state.



Pump out state



Equalize out state

**State Machine Diagram**

The triggers to the defrost in the refrigeration processing are:

- a). A schedule is true, or
- b). A manual defrost override is set.

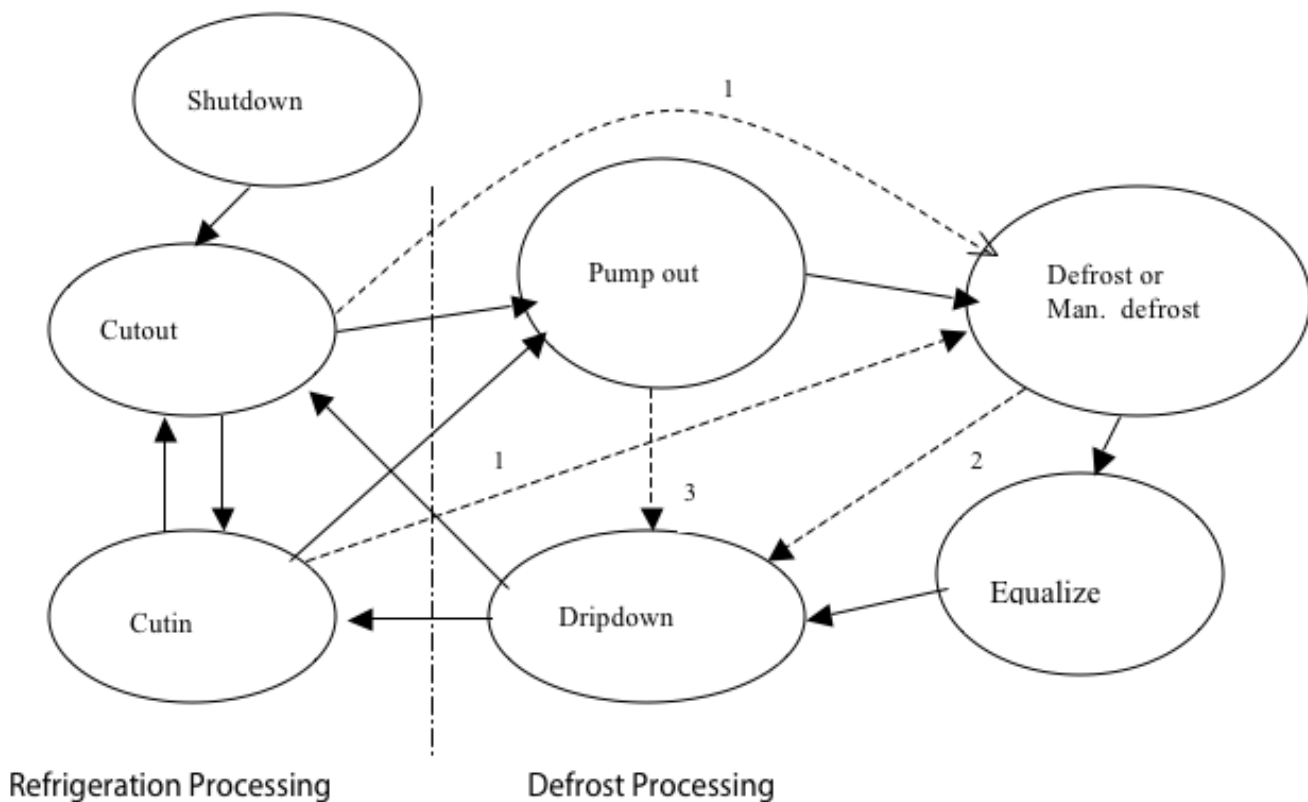

- NOTE:**
1. Go to the defrost (or Man. defrost) state if the pump-out feature is disabled.
  2. Go to the dripdown state if the equalize phase is disabled.
  3. Go to the dripdown state if manual defrost OFF is set, or if the pump-out timer is timeout and if setup for some type of defrost terminations and it's done in the pump-out period.

### Termination

Any programmed termination temperatures and/or inputs will not affect the pump-out time period. The pump-out period cannot be stopped by defrost termination. Only a manual defrost override can stop the pump-out phase, and then the drip down time will start and finish as programmed. Don't need to go through the equalize phase because a defrost phase is not involved.

Any programmed termination temperatures and/or inputs will not affect the Equalize time period. The equalize time period cannot be stopped by defrost termination. If a defrost is stopped, the equalize time will start and finish as programmed.

### Manual Defrost

When a manual defrost is initiated and the pump-out feature is activated, the pump-out period will occur as programmed. Only a manual defrost override can stop the pump-out phase, and then the drip down time will start and finish as programmed.

When a manual defrost is initiated and the pump-out feature is activated, the Equalize period will occur as programmed. A manual defrost cannot circumvent the programmed Equalize period.

### Fan Control

The evaporation fan is always ON during the pump-out period and the evaporation fan's operation during defrost is dependent on its control setup. After the defrost period ends, the evaporation fan will honor temperature and time restart parameters.

Added a question "**Fan start sensor on ...?**" in the configure circuit screen to handle the following fan control situations:

The defrost termination sensor setup 1:

The termination sensor type is selected as "Defrost sensor",

The number case/box sensors is larger than 1,

The termination input for each case is "YES".

and the fan control setup:

Fan control is "YES",

Fan delay control is "YES",

Start fan on time is "NO".

The defrost termination sensor setup 2:

The termination sensor type is not selected as "Defrost sensor",

The number case/box sensors is larger than 1,

and the fan control setup:

Fan control is YES,

Fan delay control is YES,

Start fan on time is NO.

The reason for this question is that the AK-SC255 needs to know which of defrost sensors should be chosen to compare with the fan start temperature set point because the number of defrost sensors is larger than 1. The fan control algorithm should be looking at the defrost sensors not the case sensors. For the question "Fan start sensor on ...?" we have the following choice: **All, Any, Average and Individual defrost sensor**. The default is set to Any.

A failsafe timer is added for restarting the fan on temperature in case the defrost sensors may be failed. The default time is 5 minutes.

**NOTE** (related to the fan control):

(1). "Stop fan on high temperature" is based on the Circuit or Case temperature sensor(s).

(2). "Start fan on temperature" (i.e. "Start fan on time...?" is set to NO) is based on the Defrost sensor(s).

(3). The defrost termination could be based on temperature or inputs. If it is based on the temperature, the defrost sensor(s) should be chosen to decide the termination.

(4). Refresh the question "Start fan on time....?" after changed the following each setup:

a). "Num case/box sensors ....?"

b). "Termination type ....?"

c). "Term input for each case?"



### Shutdown, Schedules and other Programming Operation

The pump-out timer and the Equalize timer will obey the shutdown inputs; schedules and other programming that would stop the overall defrost process from beginning.

### History

The history parameters for the pump-out feature and the equalize phase can be configured from the relay outputs screen in the history configuration.





## Compressor, Condenser, Heat Reclaim, Exhaust fan control (Kroger applications)

The following section describes updated control processes when controlling compressor, heat reclaim and exhaust fan applications, typically found in the Kroger store formats. Although not exclusive to Kroger, the following control description is based on customer specifications.

### Compressor control:

#### Minimum Cycle Time

The method is to let the off time determine the next minimum runtime. There needs to be a programmable total cycle time. A compressor can not turn off until the next minimum running time has expired unless turn off on safeties.

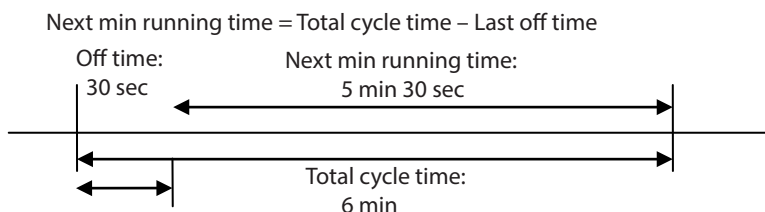

### Configuration

Under Configuration/Refrigeration/Compressors page there is a new 'Yes/No' question, "Use min running time....? Yes/No" (see below screen grab) if the following conditions are true:

- (1). one compressor is configured (Single version of AK-SC255)
- (2). one suction group is configured (Rack Version of AK-SC255)

The user can enable or disable the feature with selections. A "YES" to this question will activate the feature and then the total cycle time can be set. A "NO" will disable the feature and therefore no impact to the compressor process.

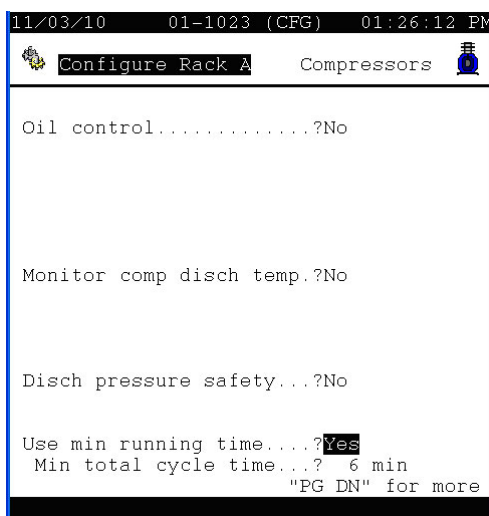

The total cycle time:  
 Default setup = 6 minutes,  
 The range = 4 ~ 12 minutes.

### Status and Settings

In the status screen (see below) the following statuses will be displayed if the min running time is enabled:

"Cycle Time" is for the user defined total cycle time.

"Last offtime" represents the last off time.

"Min runtime" represents the next min running time.

"Timer" is a decreased timer which starts at the "Min runtime".

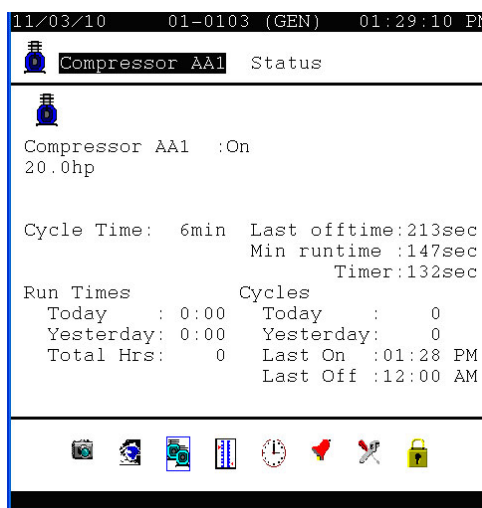

#### NOTE:

- (1). If next min running time < 0 (or last off time > total cycle time), set next min running time = 0 (default to 0).
- (2). If an override shutdown is true, then first stop the min running time's timer and save the last cutout time.

In the setting screen (below), the user can change the following setting if the minimum running time is enabled:  
**“Minimum Cycle Time”** is the user defined minimum total cycle time.

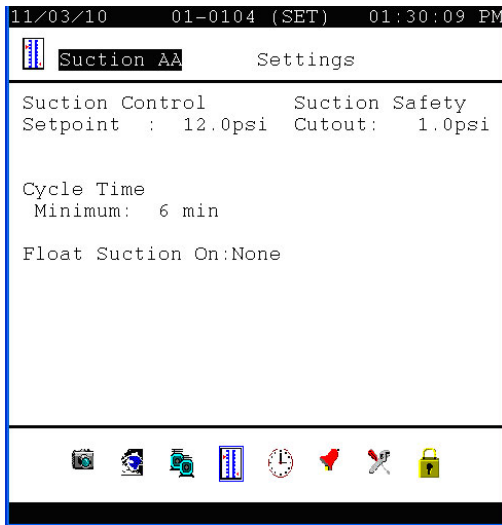

### Floating Suction Pressure Setpoint

The temperature target and its range in the circuit configuration section must be configured because they will be used by the adaptive suction control algorithm to float the suction pressure setpoint. When the Dynamic suction control feature is enabled and the temperature target is selected to "None", the temperature and its range will be removed from the screen. The temperature target must be configured because it is used by dynamic suction float control. To display and configure the temperature target in this situation, please follow the steps below:

- (1). Set the question "Adaptive suction control?" to "Dynamic" in the suction configure screen. This will activate the configuration question "Include in suction float? Yes". The default answer is Yes.
- (2). If the temperature control is selected to "None", a question "Target ... ? 35.0F" will be displayed.
- (3). Furthermore, if multi cases are selected, a question "Controlling sensor ... ?" will be displayed.

The dynamic control should be enabled in order to float the suction pressure target.

### Minimum Cycle Time Control Process

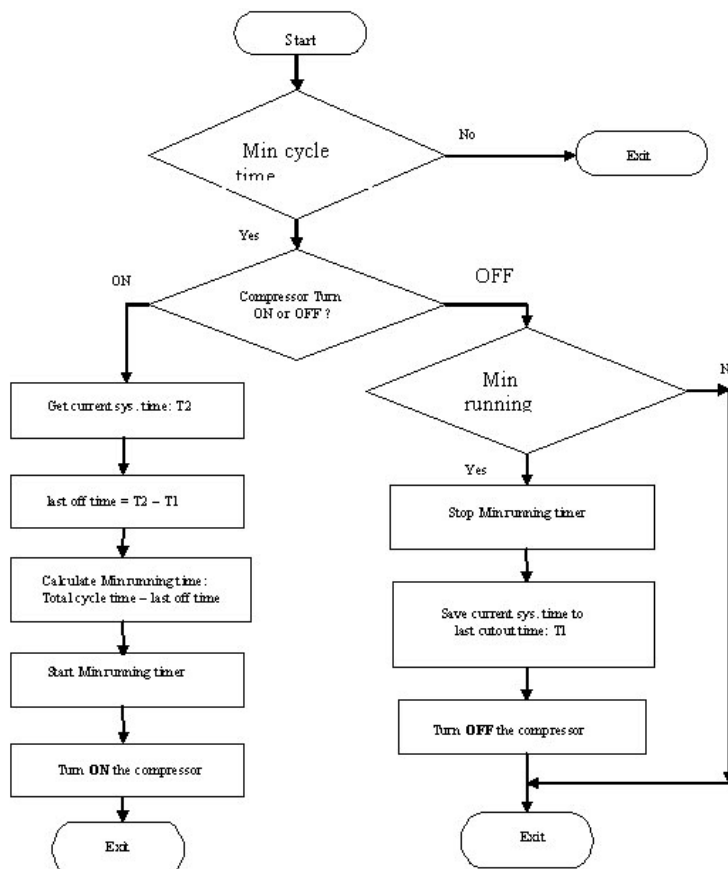

## Condenser Control

### Condenser Control Conditions

If the configuration conditions are met as:

- (1). the condenser is configured to Air cooled,
- (2). Auto-rotate-fans is configured to NO
- (3). fan type is selected to Multi Fans and number fans  $\geq 3$ ,
- (4). Individual staging,
- (5). No inverter control for this feature,

then show the 1st Stage fan interlock question as below:

"1st Stage fan interlock...? Yes/NO" and then set the 1st stage fan on setpoint: Default to 55 °F and range 30 ~ 100 °F, set the 1st stage fan on deadband (or range) Default to +/- 2 °F and range 0 ~ 20 °F.

If selected YES for the question, AK255 will configure the condenser to:

1. TD control strategy with dropleg temp sensor,
2. Allocate the dropleg temp sensor if necessary,
3. The neutral zone for the target control type (no variable speed control),
4. Hide questions "Control sensor.....?","Monitor dropleg temp...?" and "Target control type.....?"

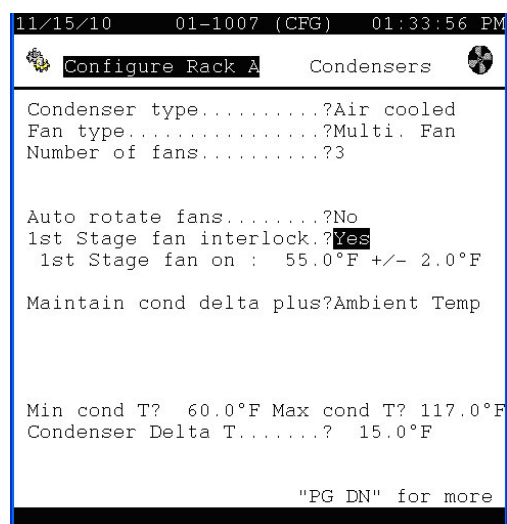

## Control Processes

1. If the current stage is the 1st stage fan and the 1st stage fan interlock is enabled, then do the following process check: if the compressor is ON and dropleg temp > Setpoint turn ON the 1st stage fan turn OFF the 1st stage fan.
2. If heat reclaim is configured and it is ON, then turn OFF the 1st stage fan, but allow other fans running.
3. If the compressor is OFF, then turn OFF all the fans.

## Status and Settings

In the status screen (below left), the following status will be displayed if the 1st stage fan interlock is enabled: "1st fan T" is for the 1st stage fan on setpoint.

In the setting screen (below right), user can change the following setting if the 1st stage fan interlock is enabled: "1st Stage fan on" is for the 1st stage fan on setpoint and its deadband.

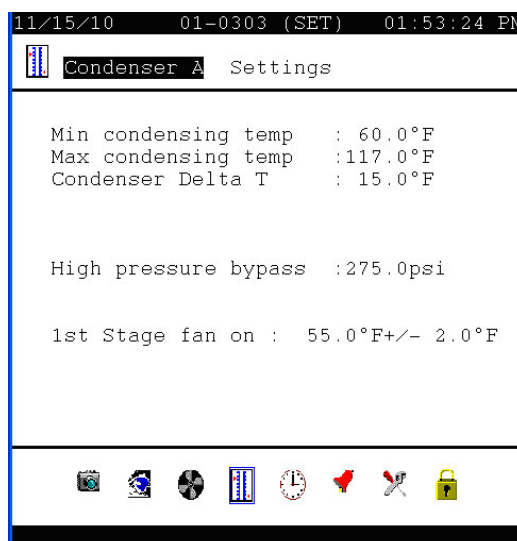
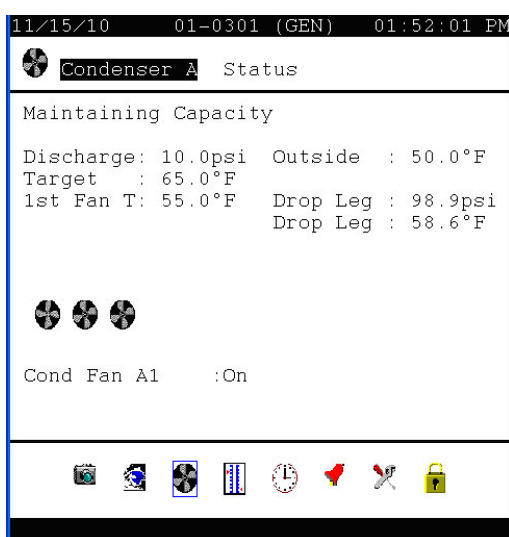

### Heat Reclaim Control for Singles

Added a Heat Reclaim control section into the AK-SC255 Single Version software:

1). In the single compressor configuration screen, a new "Heat Reclaim" button appears. It will link to the heat reclaim configuration screen

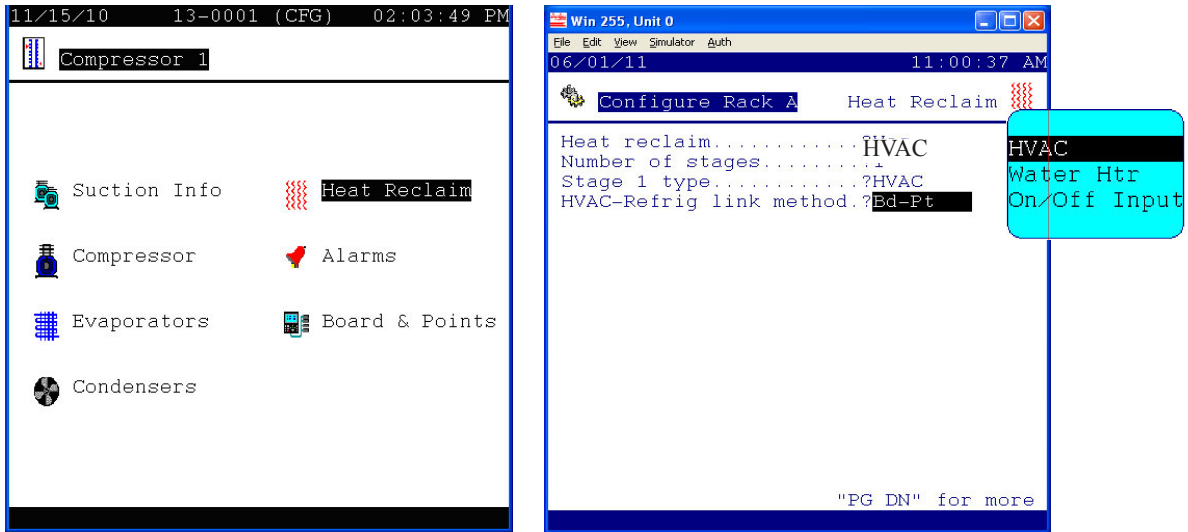

2). In the single compressor status screen 13-0002, add a "Heat Reclaim" button. It will link to the heat reclaim status screen.

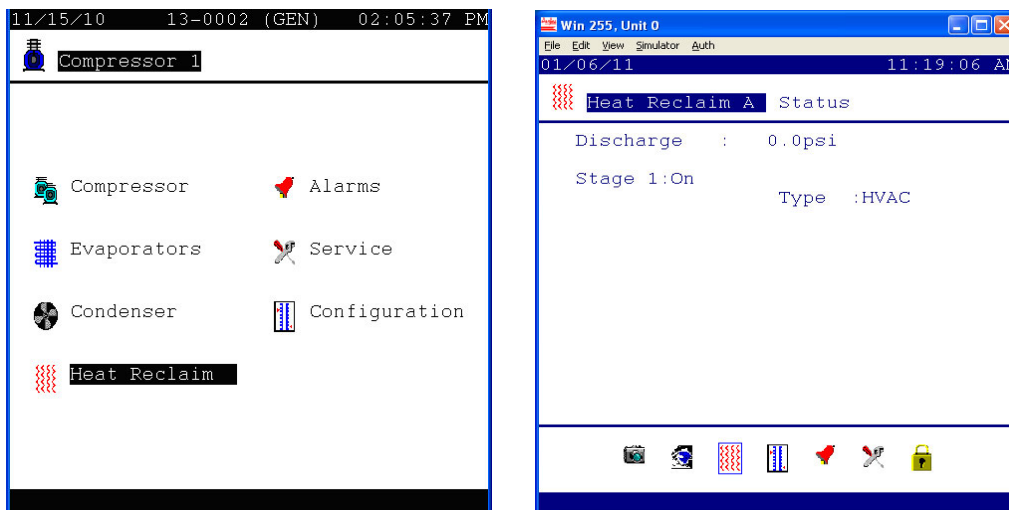

3). In the single compressor service screen a new "Heat Reclaim" button has been added. It will link to the heat reclaim service screen

### Exhaust Fan Control

Exhaust Fan Button. Add an exhaust fan control into the refrigeration section (both Rack version and Single version). An "Exhaust Fans" button is added to the top level refrigeration control screens (for Rack version software see below left, for Singles version see below right).

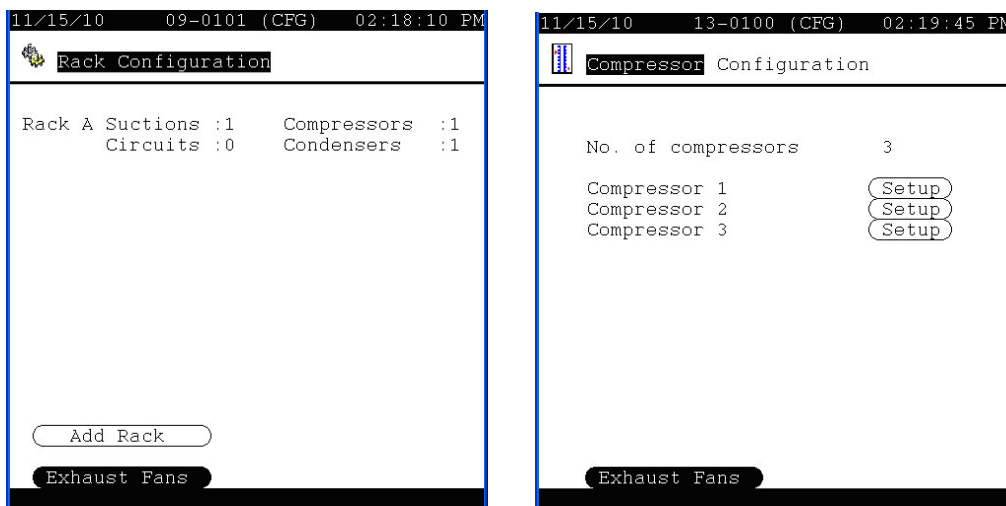

In the configure exhaust fan screen, a configuration question “Configure Exhaust Fans.....? Yes/No” is displayed with a default answer “No”.

After selecting “Yes” for the question, three configure buttons will be displayed. They are:

1. Exhaust Fan – link to the configuration screens of exhaust fan,
2. Alarms – link to the configuration screens of alarm,
3. Board & Points – link to the Bd-Pt configuration screens.

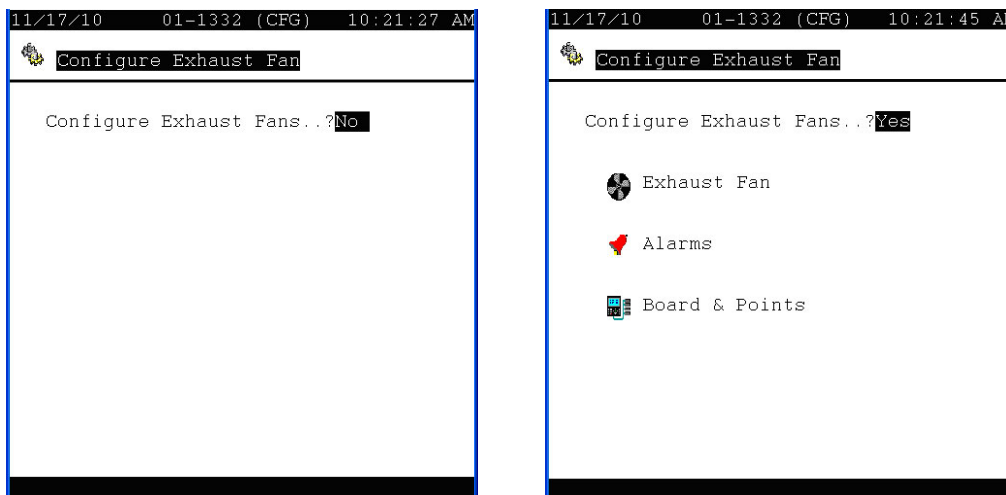

### Exhaust Fan Configuration

Select Exhaust Fan and press ENTER, and now the Exhaust Fan Configuration screen appears. In this screen, the following fields are shown:

Number of fans (1 to 12) The number of exhaust fans in the system.

Fan stage monitoring (Yes/No) Fans will be monitored with a digital input (on-off input) created for each fan.

Auto rotate fans (Yes/No): Auto rotate fans.

Target control type (List box):

Ramp together: Where there is variable speed fan motor control, fans will come on in stages at minimum speed, then all will be ramped up together.

Ramp stages: Where there is variable speed fan motor control, each stage will be brought on and ramped up. When a stage is at maximum speed and additional fan capacity is needed, the stage will be dropped to minimum speed and the next stage brought on at minimum speed, then ramped up as required.

Neutral Zone: Danfoss Neutral Zone control will be used. This is a strategy that operates to move current value closer to target more rapidly the farther away the current value is from target.

Rate of change: An algorithm of an earlier generation that approximates PID control by causing slower capacity change as the current temperature approaches target, and larger changes when current temperature is more distant from target temperature.

Ramp stages if ambient (-99.0 to 150.0, +/- 0.0 to 9.9) If Ramp together is selected, the strategy will change to ramp stages if the ambient temperature is less than this setpoint.

TD Control Mode (Amb Temp > SP):

Min Temp (0.0 to 200.0) The target minimum temperature that the controller will strive to maintain. Target is calculated by adding outside temperature and the exhaust fan’s design temperature differential.

Max Temp (0.0 to 200.0) The target maximum temperature that the controller will strive to maintain. Target is calculated by adding outside temperature and the exhaust fan’s design temperature differential.

TD Control Delta T (0.0 to 50.0) The exhaust fan delta-T furnished by the exhaust fan manufacturer.

Use the page down button to access the following screen, which will show inverter control (if used).

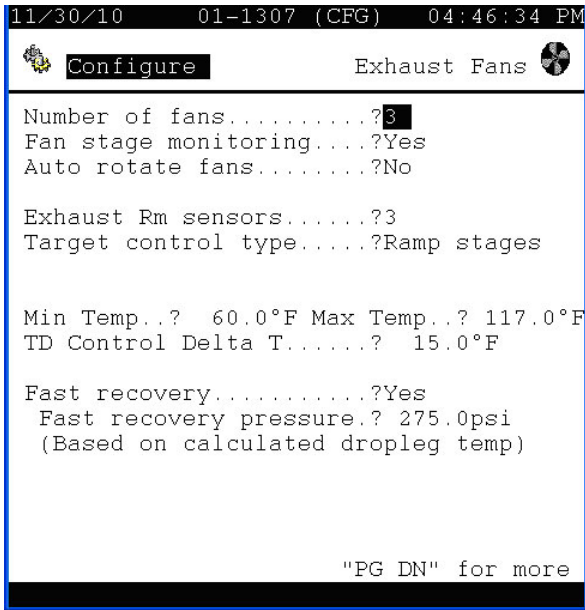

The fields in the configure exhaust fans screen are as follows:

Fan inverter control (List box)

None: No variable speed drive is controlled.

VO: An analog output, also known as a VO (variable output) point on a Danfoss I/O module will control the variable speed drive.

Min speed (1.0 to 150.0) The minimum percentage of the maximum RPM that the fan motors will be run. Insure that the entries on this screen are within the manufacturer's specifications.

Max speed (1.0 to 150.0) The maximum percentage of the maximum RPM that the fan motors will be run. Insure that the entries on this screen are within the manufacturer's specifications.

RPM at max speed (1 to 6000) The RPM at the maximum percentage specified in the previous setting.

Inverter max resets (0 to 10) The maximum number of inverter resets, after which a subsequent reset condition will place the inverter in override.

Inverter reset delay (1 to 600) The number of seconds that must elapse between inverter reset attempts.

Inverter proof delay (1 to 600) The number of seconds without proof before an inverter reset is attempted.

Reaction Zone and Time: The following screen (page down) exhaust fan configuration has neutral zone control parameters for the PI control algorithm. The fields are as follows:

[Informed adjustment of these settings is best done by Danfoss-trained technicians.]

Normal Reaction Zone (0.1 to 100.0) The range of temperature on either side of the target in which the exhaust fan control algorithm reacts with normal sensitivity.

Plus Zone (10 to 900) The PI algorithm sensitivity when current control sensor value is above the normal reaction zone.

Minus Zone (10 to 900) The PI algorithm sensitivity when current control sensor value is below the normal reaction zone.

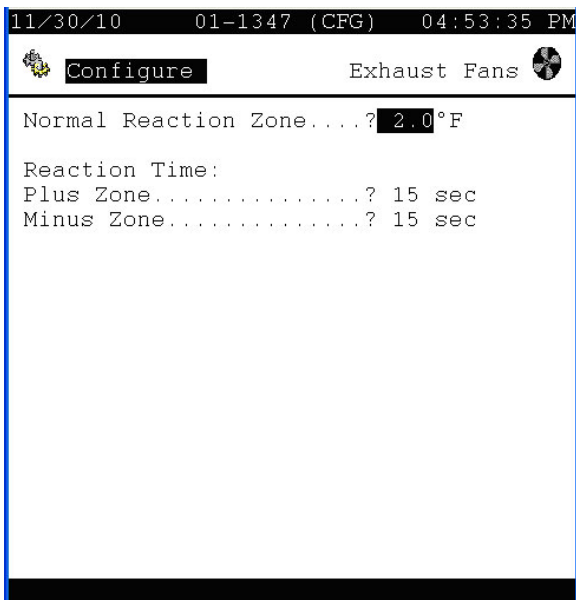

### Exhaust Fan Control Algorithm

Exhaust Fan Control will follow one of two algorithms based on ambient temperature and mode change setpoint:

- a). If ambient temperature is above a programmable mode change setpoint, control should follow a 'standard TD strategy (TD mode)' where multiple exhaust room sensors can be averaged out and compared to ambient for control (basically just as condenser control averaging multiple sensors).
- b). In the control modes, we will be driving multiple VFDs with a 0-10V signal, and utilizing relays for each exhaust fan. We would want all our standard VFD condenser options to remain, such as min/max speed, ramping options, etc.
- c). Add a 'fast recovery (FR Mode)' strategy where multiple dropleg temp sensors in the exhaust room are averaged out and converted to saturated pressure, and used as an override to turn all fans on when above a programmable setting. AK-SC255 will display the following warning statement if user is trying to enable the feature but there is no a configured dropleg temp sensor in the system.

"The function is NOT available because there is no a configured dropleg temp sensor"

- d). There would be some sort of time delay or deadband for the switch from TD mode to Plenum mode in the event ambient is hanging around the switchover setpoint, resulting in control issues.

### Exhaust Fan Configuration Assumptions

The control process of the Exhaust fan system is based on the following assumptions:

- 1). it is configured as an Air cooled condenser system,
- 2). it has multiple fans,
- 3). its fan staging is configured to individual,
- 4). control sensors of the system will be exhaust room sensors or plenum room sensors,
- 5). the target control type is the same for TD mode and Plenum mode,
- 6). the inverter of the system is VO (don't include VLT),
- 7). need to configure both TD mode and Plenum mode at the same time.
- 8). the parameter type of Normal Reaction Zone is temperature (°F).

### Status

The status screens of exhaust fan control include the following screens:

The exhaust fan status page below will reflect the following points;

Control: showing the current control mode – TD mode or Fast recovery mode.

Exha Rm Temp: display the averaged temperature of exhaust room sensors if the system is in the TD mode.

Drop leg: averaged dropleg temperature and convert to pressure.

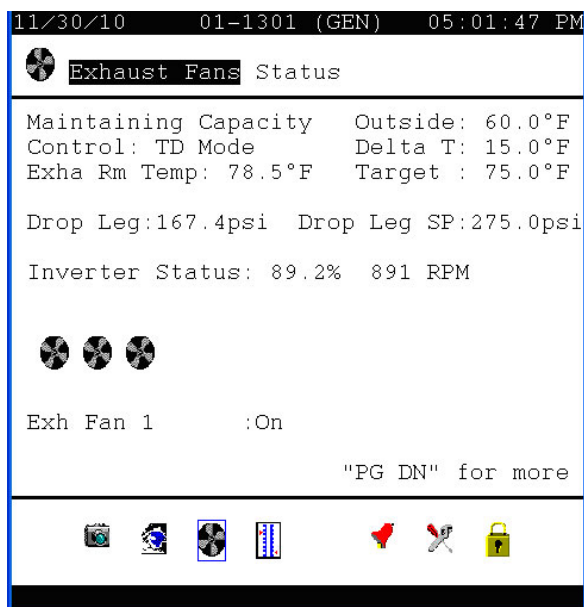

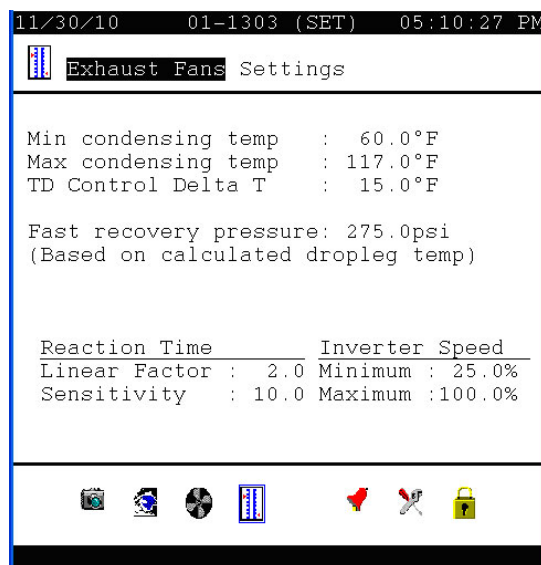
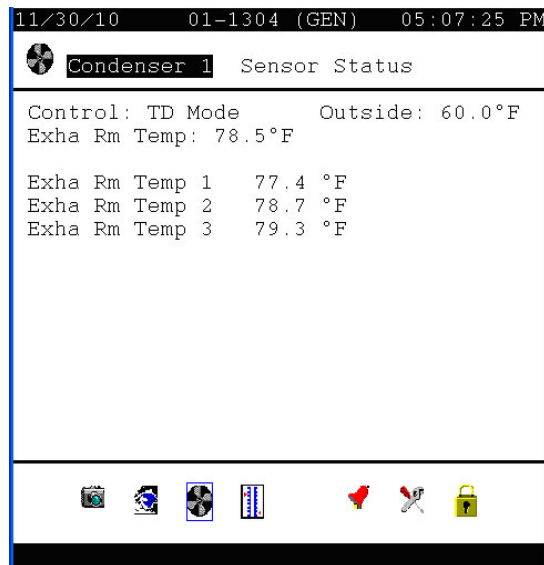
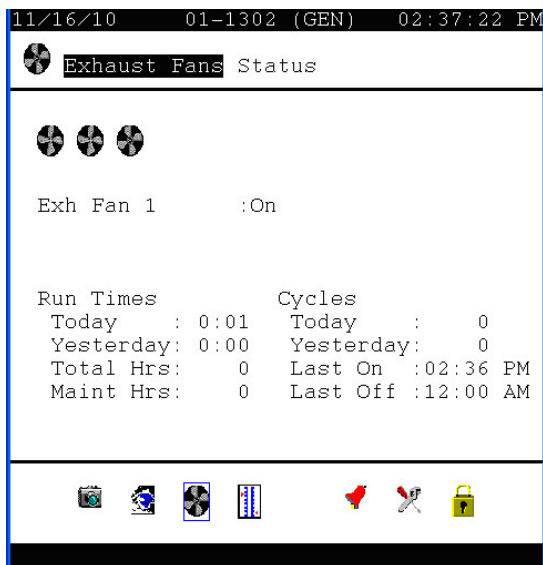

### Alarms

The following alarm points are new in the AK-SC255:

- Inverter Hi Reset Alarm,
- Inverter Failure,
- Exhaust Fan Failure 1 – 10.

### History

The history parameters for Exhaust fan control can be configured from the Board & Points screens in the history configuration. Two extra history parameters (exhaust room averaged temp and exhaust fan target temp) can be configured from the Other Datapoints screen.

### Manual Override Mode

The new features do not affect the manual override mode in the exhaust fan control (Manual On and Manual Off).



## Dehumidification- Reheat

The following screen represents a new feature added in 02\_165 software. This feature supports packaged RTU's with dedicated dehumidification functions (reheat relay).

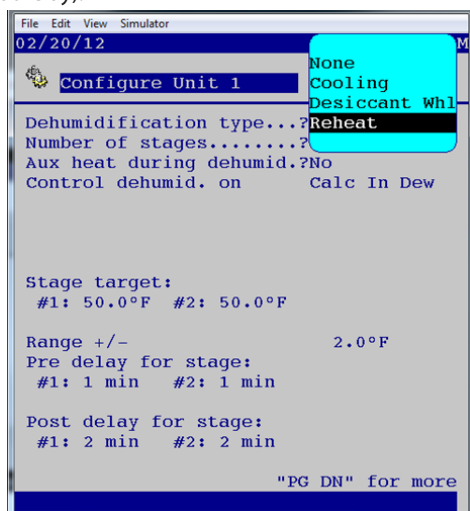

## HVAC Heating - Individual setback for heat reclaim / Aux heat

The following screen represents a new feature added in 02\_165 software. This feature supports individual setback and schedules for heat reclaim and aux heat

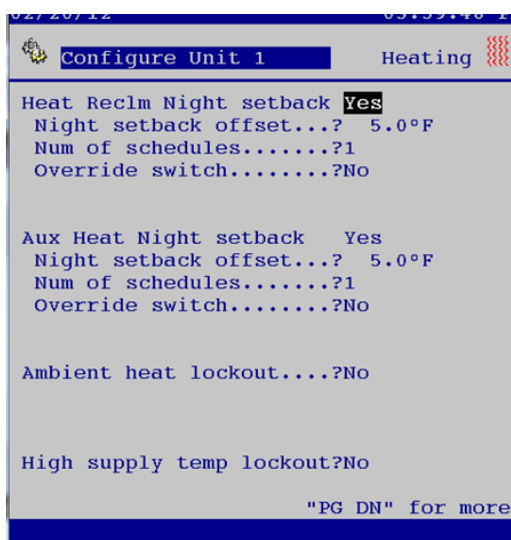

## Refrigeration->Condenser hot gas ambient lockout and offset

The following screen represents a new feature added in 02\_165 software. This feature provides user definable hot gas defrost offset, with ambient lockout protection.

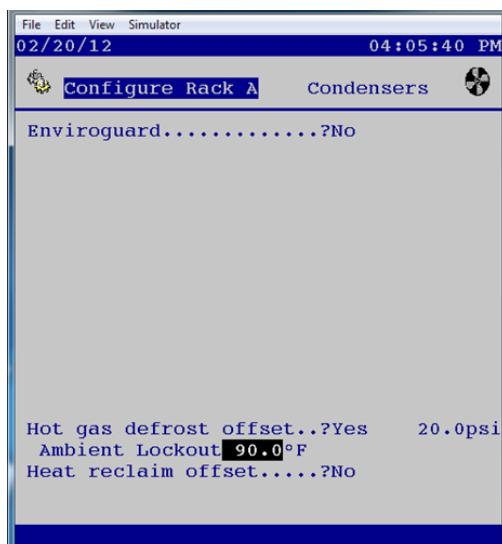

## Square D PowerLink® G3 Lighting panel support over Modbus

The following section describes the AK-SC255 screen configurations for the Square D G3 PowerLink® Modbus interface. For detailed panel configuration please consult the relevant documentation which accompanies the G3 Modbus lighting panel. The interface supports 1 master panel and up to 7 slave panels.

### Powerlink Panel specifications

- Modbus address – 232 (master i.e. the panel with power supply)
- Left bus of master – 232, right bus of master – 233
- Slave address selector on each slave set to 1, 2, 3 and so on
- Slave panel left bus – 234, right bus - 235
- Baud Rate – 19200, Parity - None
- Breaker types – 1 pole, 2 pole, 3 pole
- Max bus length – 21
- All Powerlink Breakers have a single electronic connection. The two (2) pole breaker control connection will be the top pole when breaker is mounted on the panel left side. Control connection will be on the bottom pole when that breaker is turned and mounted on the panel right side. Control connection for the 3-pole breaker is the centre pole regardless of mounting position.

### Configuration

The following section describes the configuration steps for Powerlink panels. Assuming a suitable Modbus connection has been made, ensure your AK-SC255 is set to scan on the Modbus channel (Communications->I/O Network->Rescan channels), making sure the option for SLV is set to NO.

Once scanned any lighting panels discovered will be shown in the I/O Network Overview screen.



When communicating via Modbus any local PowerLink® G3 panel displays must be removed in order to ensure correct scan on the Modbus channel

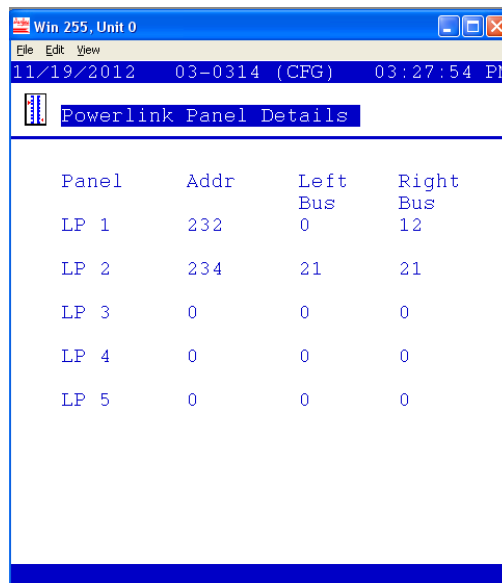
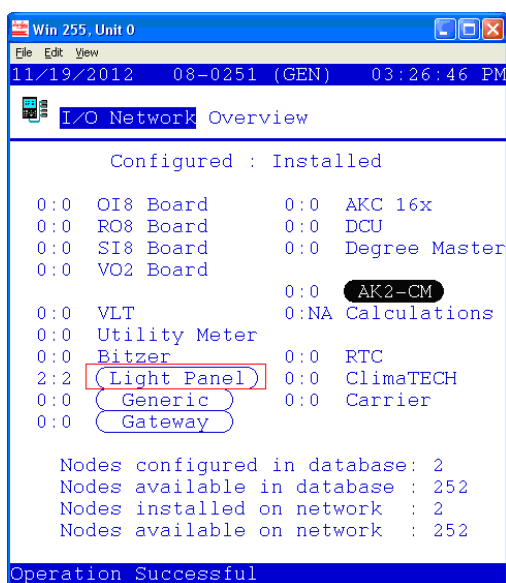

Under the Configuration->Lighting screen enter how many zones are required. Select **G3M** for the Modbus version and ensure PWRLK is selected for the zone type. Under the Lighting configuration screen, select board and point and navigate to the Lighting Panel icon (bottom right on screen). Under the setup button the following screen allows for which zone is assigned to which breaker.

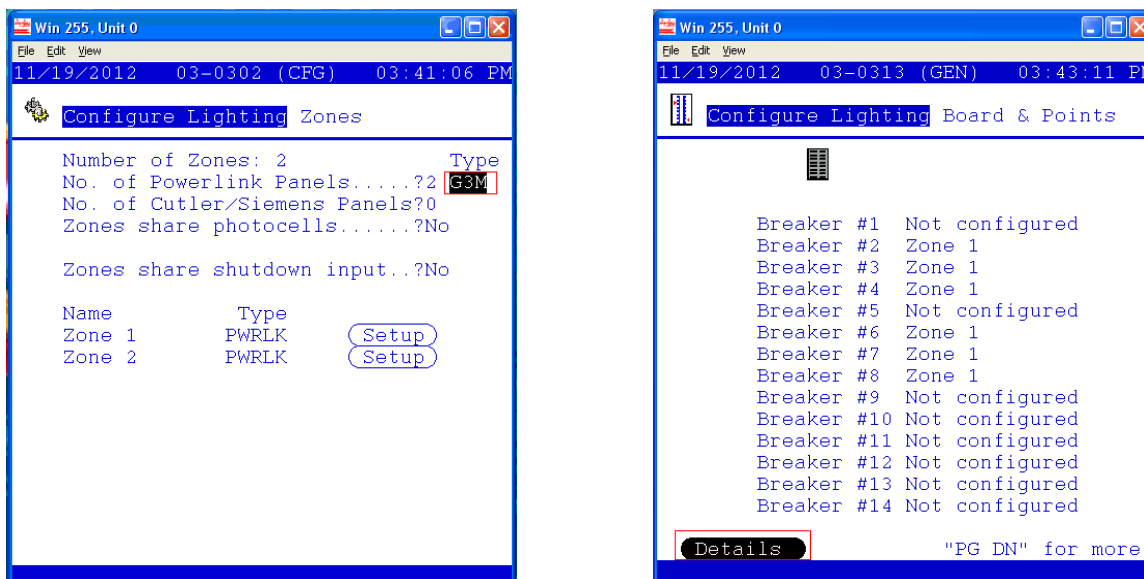

Use the details button to access the Powerlink panel detail screen. This displays the type of breakers installed on both left and right bus of a Powerlink panel. In case of multi-pole breakers, the dummy phases are indicated with a '2-' or '3-'.

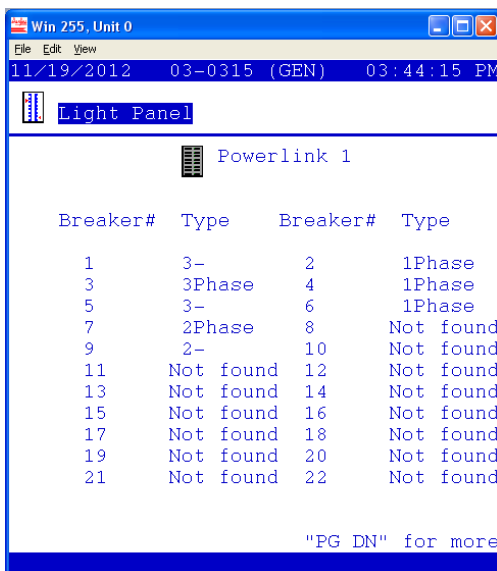

Due to the network topology and speed of communication to the lighting panels there is typically a 10 second interrogation time for each panel. The result of this communication time may be reflected as 'no response' in the AK-SC255 user screen. The response time is proportional to the amount of installed and online panels. This is expected behavior and not a fault.

**[www.danfoss.us](http://www.danfoss.us)**

ADAP-KOOL® Refrigeration Control Systems is a trademark of Danfoss A/S, [www.danfoss.com](http://www.danfoss.com)

Danfoss can accept no responsibility for possible errors in catalogs, brochures, or other printed material. Danfoss reserves the right to alter its products without notice. This also applies to products already on order provided that alterations can be made without subsequential changes being necessary in specifications already agreed. All trademarks in this material are property of the respective companies. Danfoss and the Danfoss logotype are trademarks of Danfoss A/S. All rights reserved.